

Mini High Performance Tunnel

TLA-1040

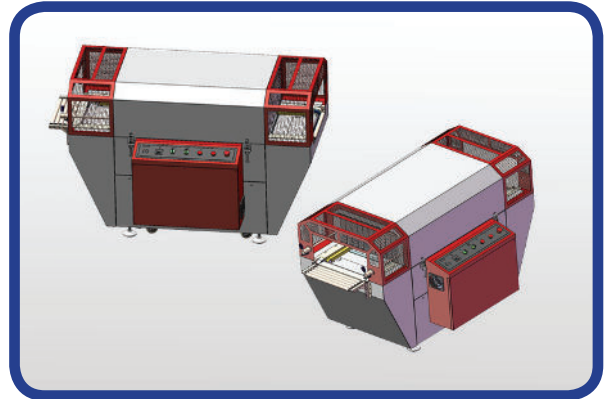

Features:

1. Thermal circulation system using high integrated design, rapid temperature raise up.
2. SSR and PID temperature control, temperature tolerance down to +/- 1°C.
3. Auto shut down function when temperature drop to 70 °C, save time and energy.
4. Adopt long life metal heater, durable and stable.
5. Heater drawer design, for easy inspection and heater connecting and replace.
6. Conveyor speed 1-18M/min adjustable by VTV speed controller and AC motor.
7. Standard live roller design.
8. Air flow from bottom to ensure perfect shrink result.
9. Insulating layer between the heating zone and outer wall about 100mm to minimized heat lost.
10. Tunnel exit with short transfer free roller with angle adjustable.
11. Both side lateral air flow direction adjustable.
12. With casters.

Options:

1. Stainless steel machine construction
2. Openable tunnel cover
3. Difference tunnel open height available

Technical Specification

Model	TLA-1040
Tunnel size:	L 1000mm x W 400mm x H 250mm
Machine size:	L 1600mm x W 960mm x H 1206mm
Conveyor working height:	823mm + 50mm
Heater power:	9KW
Total power:	10KW
Voltage:	380V, 3 phase, 50Hz, 16A or 220V, 3 phase, 60Hz, 26A

All major parts use foreign product.

Alpha-PACK System
 歐華包裝企業有限公司
Alpha-Pack Enterprise Ltd.

leading specialist of packaging machinery manufacturer
 Unit 1406 Vanta Industrial Center
 21-23 Tai Li Pai Road, Kwai Chung, Hong Kong
 Tel: (852) 2416 1237 Fax: (852) 2264 6540

Over 20 years' packaging machinery manufacturer
 Since 1991

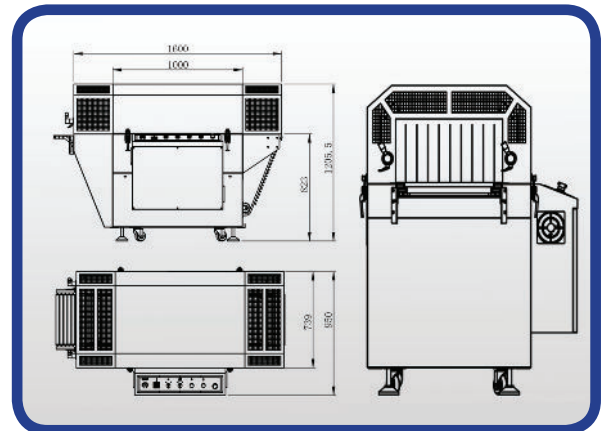

Compliance with CE & UL Standard



www.alpha-pack.com.hk



sales@alpha-pack.com.hk
export@alpha-pack.com.hk