

WULFTEC® STRETCH WRAPPERS WRW-Spin Horizontal



*Put a positive spin on your packaging with
Wulftec's WRW-SPIN horizontal stretch bundlers*



Our know-how demonstrated in an affordable horizontal stretch bundler

Built with the same quality as every Wulftec stretch wrapping system, the WRW-SPIN is a horizontal stretch bundler suited for various applications

A great alternative to strapping, taping, poly bags, corrugated materials or other unitizing methods. It minimizes total packaging costs (labor & material) compared to hand wrap. The preferred way to wrap long products that can't be wrapped on conventional wrapping machines.

Flexible and custom built, the WRW-SPIN can be integrated into your exiting line to maximize productivity.

Use as a fully automatic machine with conveyor lines in & out or as a semi-automatic machine with customers pushing loads through the machine for continuous wrap.

The Wulftec Advantage:

- Non-proprietary parts
- Easy integration into existing lines
- Local support with qualified technicians for installation, integration, repairs, inspection...
- Parts delivered within 24 hours
- We offer advisory service



WWW.WULFTEC.COM
WE FEAR NO PACKAGING CHALLENGE

Technical Specifications

WRW-Spin

Production rate ¹	Up to 200 loads per hour
Load size	Maximum diagonal load dimension must be 8" smaller than ring size (4" on each side)
Maximum Load weight	Maximum load weight limited to conveyor capacity
Machine dimensions	Machine dimensions depending on ring size
Electrical requirements	230V/3/60 15A
Pneumatic requirements	Up to 3 CFM @ 80 PSI comes with Filter/Regulator
Film delivery system	<ul style="list-style-type: none"> 10" adjustable mechanical tensioning brake Rapid-lock film roll device
Available ring sizes	18, 24, 36, 48, 60 and 72 inch diameter
Options	<ul style="list-style-type: none"> Top hold down Side guides (manual or automatic) Touch screen with advance programming Conveyors (belt, chain, rollers, gravity)
Structure	<ul style="list-style-type: none"> Heavy-duty structural steel construction Ergonomically friendly film loading carriage position
Warranty	<ul style="list-style-type: none"> 3-year unlimited cycle warranty 10-year warranty on steel structure

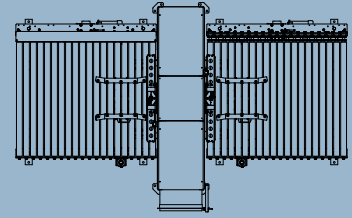
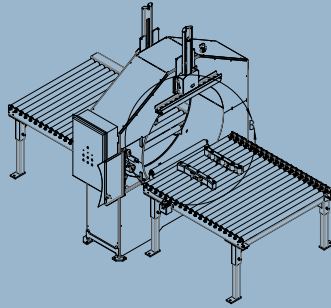

The Wulftec engineering team has redefined the boundaries of horizontal stretch bundlers



Automatic cutting/clamping finger safe unit



Fully enclosed wrap zone for more protection



Touch screen and PLC allows maximum versatility : pre-set wrap patterns, various configurations, control of ring speed and conveyor speed to reach the perfect package. Allows for multiple wrap modes & banding capabilities.

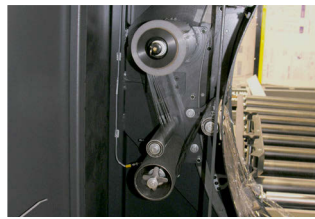

Carriage accepts 5" or 10" rolls of film. Loading clamp and rapid lock roll device. Easy & quick access to the carriage for simple re-loading. Adjustable film tension directly on the carriage.

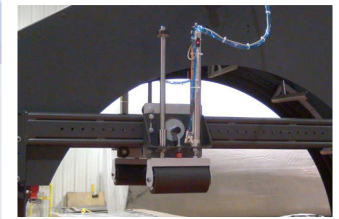

Popular options include: infeed and outfeed conveyors, side guides, top hold downs, touch screen & advanced controls, supporting bridge, etc...

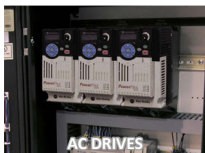

1. Production rate based on load and machine size and configuration

All machine specifications are subject to change without prior notice / Nominal dimensions shown WRW-Spin shown with optional conveyors



WULFTEC

A DURAVANT COMPANY

Wulftec International Inc.

209 Wulftec, Ayer's Cliff, Quebec, Canada J0B 1C0

Toll free: 877.WULFTEC (985.3832)

Phone: 819.838.4232

Fax: 819.838.5539

Email: wulftec@wulftec.com



WULFTEC IS A MEMBER OF THE DURAVANT FAMILY OF COMPANIES

FOOD SORTING & HANDLING | PROTEIN PROCESSING | PACKAGING | MATERIAL HANDLING

www.duravant.com