

WULFTEC® STRAPPING MACHINERY LMB-250 Lumber Press

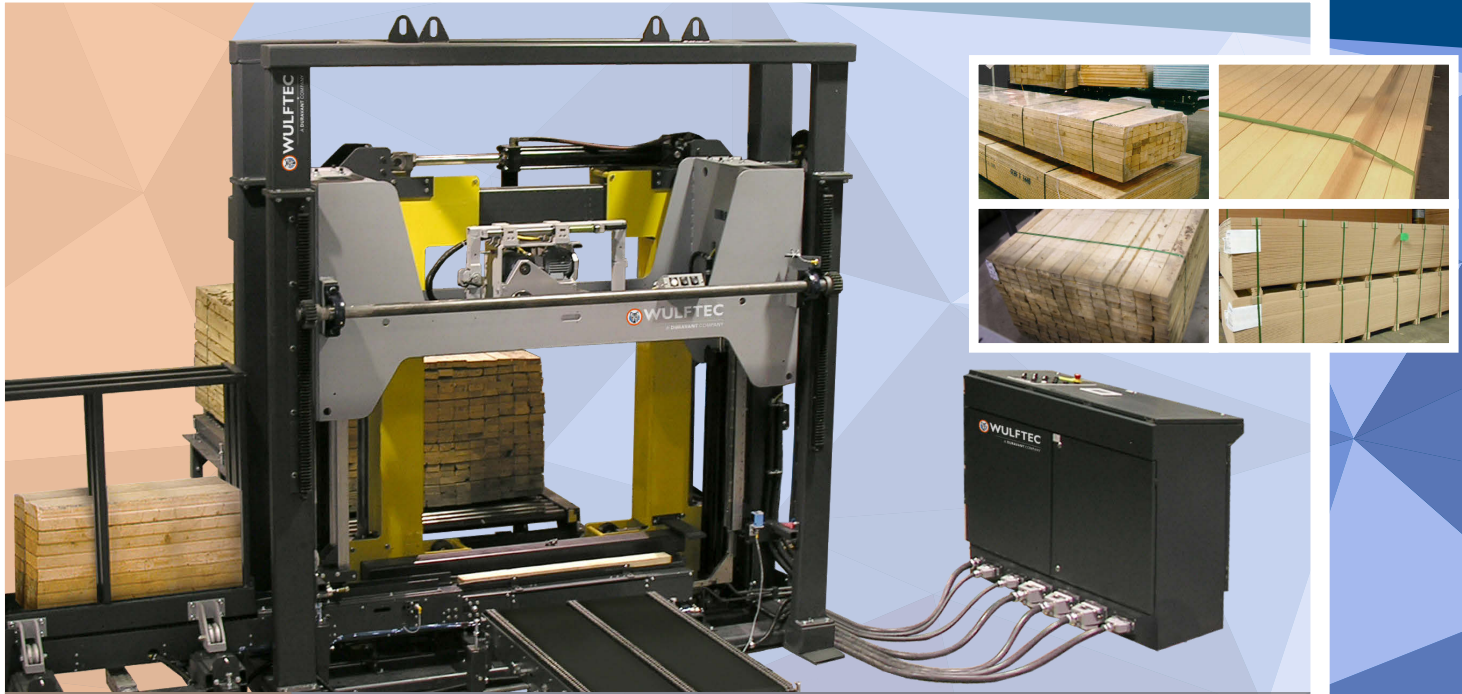

A DURAVANT COMPANY



FULLY AUTOMATIC STRAPPING SYSTEM TAILORED TO THE LUMBER AND PANEL INDUSTRIES

The hydraulic compression strapping system design facilitates maintenance and operation. Top and side compression ensures stable, tight loads that will retain high tension during transportation. The LMB-250 Lumber Press is easily integrated into existing production lines to create a seamless packaging system.

Automatic strapping machinery backed by the Wulftec knowledge, engineering and unbeatable service.

Wulftec manufactures technologically advanced strapping systems... Becoming the choice of the most demanding customers.

Up to 25,000 lbs of Top and Side Hydraulic Compression

The LMB-250 features hydraulic compression platens for greater consistency and reliability, allowing for up to 25,000 pounds of top and side compression using an oversized dual rack and pinion equalizer system.

GT41 HT strapping head

All Wulftec strapping machines are equipped with the renowned GT41 HT strapping head. Strap seal through vibration welding providing high quality and consistent strap joints. Complete head is mounted on hinge for easy access, cleaning and troubleshooting.



WWW.WULFTEC.COM
WE FEAR NO PACKAGING CHALLENGE

Technical Specifications

	LMB-250
Machine Dimensions	58" L x 130" W x 131 1/2" H
Approx. Shipping Weight	10,000 lbs (excluding optional bunk feeder and conveyors)
Load Size ¹	Minimum: 32"W x 15"H Maximum: 60"W x 58"H
Electrical Requirements	460 V/3/60 40A
Pneumatic Requirements	3 CFM @ 80 psi
Controls	<ul style="list-style-type: none"> Allen Bradley CompactLogix L24ER PLC Allen Bradley PanelView 7 6" touch screen
Strapping Head	GT41 HT
Strap Arch Size	62"W x 59"H
Strap Type	PET
Strap Width	3/8", 7/16", 1/2", 5/8"
Strap Thickness	0.015" to 0.040"
Seal	Friction
Strap Tension	5,000N / 1,125 lbs/ft max
Top and Side Compression	25,000 lbs max (adjustable)
Structure	Heavy duty folded sheet metal uprights with upper frame structurally integrated with base for greater stability
Warranty	<ul style="list-style-type: none"> 1-year warranty on head and track 3-year warranty on other components 10-year warranty on steel structure

Features

For improved productivity and efficiency

- **Spring loaded entry roller**
- **Side compression**
 - Floating system (auto-aligned on load)
 - V-grooved roller guiding system
 - 4" bore hydraulic cylinders
 - 25,000 lbs compression force
 - Squared through rack and pinion system
- **Top compression**
 - GT41 HT strapping head
 - V-grooved roller guiding system
 - 4" bore hydraulic cylinders
 - 25,000 lbs compression force
 - Squared through rack and pinion system
- **Allen Bradley CompactLogix L24ER PLC**
- **Allen Bradley PanelView 7 6" touch screen**
- **User programmable strap patterns**

Options Available

- Top corner applicator
 - Top bunk feeder
 - Bottom bunk feeder
 - Multiple sizes of magazine bunk dispensers
 - Powered jumbo coil dispenser
 - Conveyor up to 6,000 lbs capacity
 - 3/4" strap width
 - 0.050" strap thickness
 - Electrical 380 to 415V /3/50
- Consult factory for additional options**

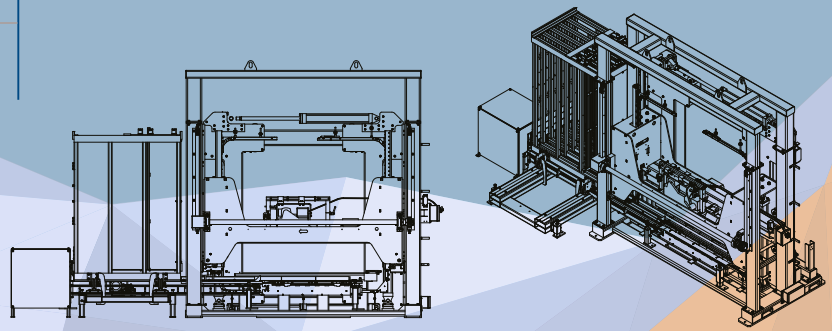

Reduced greenhouse effect: Friction sealing system does not generate harmful fumes versus heat blades.

Reduced general waste by better product protection for handling and transport: The product is properly secured to the pallet, resulting in a pallet that is more stable for transport and therefore less damage!

Reduced electricity consumption: By using variable frequency drives on all its motors, Wulftec ensures that only the power required is used, regardless of the HP of the motor. By this, we have standardized our motor sizes, allowing for less parts in inventory for us and our customers. This translates into greener operations at our end and at your end.



1. For other load sizes, contact us

- LMB-250 shown with optional conveyors and bunk feeder
- All machine specifications are subject to change without prior notice
- Nominal dimensions shown



WULFTEC

A DURAVANT COMPANY

Wulftec International Inc.

209 Wulftec, Ayer's Cliff, Quebec, Canada J0B 1C0

Toll free: 877.WULFTEC (985.3832)

Phone: 819.838.4232

Fax: 819.838.5539

Email: wulftec@wulftec.com



WULFTEC IS A MEMBER OF THE DURAVANT FAMILY OF COMPANIES

FOOD SORTING & HANDLING | PROTEIN PROCESSING | PACKAGING | MATERIAL HANDLING

www.duravant.com