



Low-Profile Semi-Automatic Stretch Wrap Machine

HANDLE-IT® SA Series

3 YEAR WARRANTY

Model 1100AA-C

Stay on Forklift!

Remote Control Operation

**Auto Film Attach, Cut, Seal,
and Film Tail Treatment**

250% Power Pre-stretch Carriage



Part Number
SWM-SA-1100AA-C

Handle-It® Model 1100

The Handle-It® Model 1100AA-C offers top-of-the-line functions and features at a great price.

Ideal for those that are looking to wrap their pallets as efficiently as possible without moving to a conveyORIZED automatic system. No need for workers to get off the forklift. This unit comes standard with a remote control that when prompted will automatically attach the film, wrap the pallet, cut the film, and heat seal the film to the pallet eliminating any film tails.

Technical Specifications

Wrap Height	86" W/ Overlap, 94" Max
Turntable Diameter	71"
Max Pallet Size	93" Diagonal
Turntable Height	3"
Weight Capacity	4,000 lbs
Pre-Stretch	250% Powered
Power Supply	110V, 20 Amp
Air Supply	Min: 90 PSI / 8 Gallon Tank
Total Machine Footprint	113" long x 71" wide
Machine Weight	1,300 lbs
Turntable Speed	12 RPM

Handle-It® Semi-Automatic Stretch Wrapper

Product Specifications

- Photocell for pallet height detection with photo eye delay
- Variable film tension
- Safety stop at base of carriage
- Adjustable carriage up and down speed
- Reinforcement wrap settings
- Wrapped pallet counter
- Brushless AC motors
- On-board diagnostics
- Stop at home position
- 3 year warranty
- 20" Carriage



Digitally controlled power film pre-stretch

for dynamically controlled film efficiency and improved load containment, both lowering consumable cost and keeping your product safe and secure



Automatic System

Requires 90 psi 8 gallon minimum air supply



Responsive and user friendly PLC controls:

- Fully customized wrap cycles
- Up to 32 programmable cycles
- 6 quick select buttons for quick navigation
- Over 50 different parameters with variable film tension and speed controls
- USB port allows upload and download of data with statistic reporting and system diagnostics

Available Options

- Auto Film Cut
- 118" Height Extension
- 24" Extended Frame
- Additional Remotes
- Top Press
- Photocell for Dark Loads
- Cold Environment Kit
- Film Usage Diagnostics
- Film Slitter for Ventilation
- 30" Carriage
- Anti-static Brush



Integrated Scale



Forklift Wheel Stop

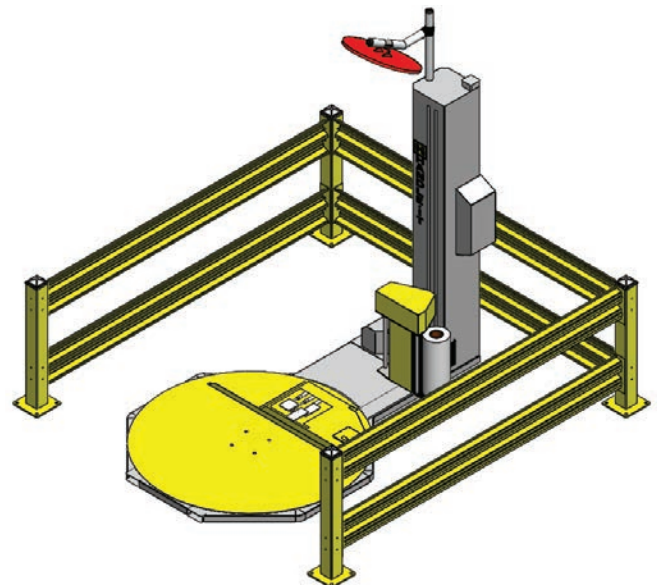

3-Sided Guard Rail Package