

Self propelled wrapping robot
ROBOT S6

Translation of the original instructions

Code: **3709301826.1**

Edition: **0117**

_____ **SERIAL NUMBER** _____

ATTENTION

**Read and understand these instructions before using the machine.
Keep this handbook for further consultation**

Summary

1. GENERAL INFORMATION

- 1.1. PURPOSE OF THE MANUAL
- 1.2. MANUFACTURER AND MACHINE IDENTIFICATION
- 1.3. TERMS AND DEFINITIONS
- 1.4. MODES OF REQUESTING FOR ASSISTANCE
- 1.5. ATTACHED DOCUMENTATION
- 1.6. HOW TO READ THE DIRECTIONS FOR USE

2. SAFETY INFORMATION

- 2.1. GENERAL SAFETY PRECAUTIONS
- 2.2. SAFETY WARNINGS FOR HANDLING AND INSTALLATION
- 2.3. SAFETY WARNINGS FOR USE AND OPERATION
- 2.4. SAFETY WARNINGS RELATED TO INCORRECT USE
 - 2.4.1. INCORRECT USE THAT CAN BE REASONABLY EXPECTED
 - 2.4.2. EMPLOYER OBLIGATIONS
- 2.5. SAFETY WARNINGS ON RESIDUAL RISKS
- 2.6. SAFETY WARNINGS FOR REGULATIONS AND MAINTENANCE
- 2.7. SAFETY WARNING FOR ELECTRICAL EQUIPMENT
- 2.8. INFORMATION AND SAFETY SIGNALS
- 2.9. SURROUNDING AREAS

3. TECHNICAL INFORMATION

- 3.1. MACHINE GENERAL DESCRIPTION
 - 3.1.1. ROLL-HOLDER CARRIAGE SPECIFICATIONS
- 3.2. OPERATING CYCLE AND WRAPPING MODES
 - 3.2.1. RUNNING CYCLE
 - 3.2.2. MODES OF WRAPPING
- 3.3. SAFETY DEVICE DESCRIPTIONS
- 3.4. DESCRIPTION OF THE ELECTRICAL DEVICES
- 3.5. DESCRIPTION OF ACCESSORIES ON REQUEST
- 3.6. TECHNICAL SPECIFICATIONS
 - 3.6.1. MACHINE AND PALLET DIMENSIONS
 - 3.6.2. TECHNICAL FEATURES
 - 3.6.3. BATTERY CHARGER S.P.E.
 - 3.6.4. BATTERY CHARGER NORDELETRONICA
- 3.7. COIL TECHNICAL SPECIFICATIONS
 - 3.7.1. REEL FEATURES
- 3.8. NOISE LEVEL
- 3.9. INSTALLATION ENVIRONMENT CHARACTERISTICS

4. INFORMATION ON HANDLING AND INSTALLATION OPERATIONS

- 4.1. RECOMMENDATIONS FOR HANDLING AND LOADING
- 4.2. PACKAGING AND UNPACKING
- 4.3. LOADING AND TRANSPORTATION
- 4.4. INSTALLATION OF DISMOUNTED PARTS
 - 4.4.1. INSTALLATION (WITH TILTED COLUMN)
 - 4.4.2. INSTALLATION (WITH HORIZONTAL COLUMN)
 - 4.4.3. INSTALLATION OF THE WHEEL FEELER AND TILLER
 - 4.4.4. LNSTALLATION OF RUDDER WITH LIGHTENED STEERING WHEEL (OPTIONAL)

5. INFORMATION ON ADJUSTMENTS

- 5.1. RECOMMENDATIONS FOR ADJUSTMENTS
- 5.2. ADJUSTING FILM "STRETCH"

- 5.3. "FRD TYPE SPOOL CARRIAGE" FORNET
- 5.4. "PDS" REEL TROLLEYS FOR CHANGING THE DRAWING RATIOS
- 5.5. REEL CARRIAGE LIFTING CHAIN ADJUSTMENT
- 5.6. BRAKE ADJUSTMENT
- 5.7. STEERING ARM RETURN SPEED ADJUSTMENT
- 5.8. ADJUSTING THE HEIGHT OF THE SENSING ARM WHEEL
- 5.9. FEELER THRUST ADJUSTMENT
 - 5.9.1. STANDARD FEELER
 - 5.9.2. LIGHTENED STEERING WHEEL (OPTIONAL)

6. ABOUT THE USE

- 6.1. RECOMMENDATIONS FOR OPERATION AND USE
- 6.2. CONTROL DESCRIPTION
- 6.3. DESCRIPTION OF THE USER INTERFACE
 - 6.3.1. NUMERIC AND ALPHANUMERIC KEYPAD
 - 6.3.2. SCHEDULE WINDOW
- 6.4. "HOME" SCREENSHOT
- 6.5. "MANUAL HANDLING" SCREENSHOT
- 6.6. "RECIPES" SCREENSHOT
 - 6.6.1. "RECIPE COPY" SCREEN
 - 6.6.2. "LEVEL COPY" SCREEN
 - 6.6.3. SCREEN "DATA TRANSFER"
- 6.7. "WRAPPING CYCLE" SCREENSHOT
- 6.8. SCREENSHOT "GENERAL PARAMETERS"
- 6.9. "PRODUCTION COUNTERS (PALLETES)" SCREENSHOT
- 6.10. "H.M.I. SETTINGS" SCREEN
- 6.11. "PASSWORD MODIFICATION" SCREENSHOT
- 6.12. "PASSWORD INSERTION (USER LOGIN)" SCREENSHOT
- 6.13. "SERVICE" SCREENSHOT
- 6.14. WRAPPING SCREEN WITH "SPECIAL CYCLES"
- 6.15. PROGRAMMING A NEW RECIPE
- 6.16. WRAPPING START AND STOP
- 6.17. FILM COIL FEEDING
- 6.18. ADJUSTING CUTTING
- 6.19. BATTERY CHARGING MODE

7. MAINTENANCE INFORMATION

- 7.1. MAINTENANCE INSTRUCTIONS
- 7.2. MAINTENANCE PERIOD TABLE
- 7.3. LUBRICATION POINT DIAGRAM
- 7.4. LUBRICANTS TABLE

8. TROUBLESHOOTING

- 8.1. ALARM MESSAGE LIST AND INFORMATION

9. SPARE PARTS REPLACEMENT INFORMATION

- 9.1. RECOMMENDATIONS FOR REPLACING PARTS
- 9.2. BATTERY REPLACEMENT
- 9.3. LIST OF THE RECOMMENDED SPARE PARTS
- 9.4. MACHINE DISPOSAL AND SCRAPING
 - 9.4.1. TAKING THE MACHINERY OUT OF SERVICE
 - 9.4.2. MACHINE SCRAPPING

10. ENCLOSED DOCUMENTATION

- 10.1. WARRANTY CONDITIONS
- 10.2. BATTERY CHARGER OPERATION MANUAL S.P.E.
- 10.3. BATTERY CHARGER OPERATION MANUAL NORDELETTRONICA

- 10.4. BATTERY DOCUMENTATION ENERSYS
- 10.5. BATTERY DOCUMENTATION EXIDE
- 10.6. BATTERY DOCUMENTATION MIDAC
- 10.7. CE STATEMENT OF CONFORMITY

1. GENERAL INFORMATION

1.1. PURPOSE OF THE MANUAL

- The manual is an integral part of the machine and is aimed to provide the operator the instructions for use in order to prevent and reduce the risks that arise from man-machine interface.
The information have been written by the manufacturer into Italian (the original language) in full compliance with the professional writing principles and the regulations in force.
The communication principles were chosen according to the target readers in order to ease the reading and understanding of the information.
The information may be translated into other languages to satisfy the legal and/or market requirements.
The manuals must be translated directly from the ORIGINAL INSTRUCTIONS, without modification.
Each translation (including that provided by the purchasing agent or by the company that introduces the machine into the country in question) must specify the message "Translation of the original instruction".
- Keep this manual for the entire duration of its useful life in a well known and easy to access place, available for reference any time the need should arise.
- In order to easily consult the specific topics of interest, check the table of contents.
- Some information may not correspond completely to the actual configuration of the machine delivered.
- Any additional information does not affect the readability of the text and the safety level.
- The manufacturer reserves the right to modify the contents of the manual without prior notice provided that the safety level is not altered.
- All information supplied by the recipients represents an important contribution to the improvement of the after-sales service that the manufacturer will offer to his/her customers.
- The symbols described below are used to highlight the most important information or specifications.



Danger - Warning

The symbol indicates extremely hazardous situations which, if ignored, could seriously jeopardise personal health and safety.



Caution - Warning

The symbol indicates that suitable actions must be adopted to prevent personal health and safety risks and avoid economic damages.



Important

This symbol indicates critical technical and operating information that shall be observed.

1.2. MANUFACTURER AND MACHINE IDENTIFICATION

The illustrated identification plate is applied directly on the machine. It contains references and indispensable operating safety indications.

- A) Machine model.
- B) Machine's serial number.
- C) Year of manufacture.
- D) Power supply voltage.
- E) Power supply frequency.
- F) Power supply phases.
- G) Electrical power consumption.
- H) Total installed power.
- L) Air consumption.
- M) Max. air supply pressure.
- N) Machine weight.
- P) Manufacturer's name.

MODELLO	A	
MATRICOLA	B	
DATA	C	
ALIMENTAZIONE	D	V
FREQUENZA	E	Hz
N. FASI	F	
ASSORBIMENTO	G	A
POTENZA TOT.	H	kW
CONSUMO ARIA	L	l/min
PRESSIONE MAX	M	bar
PESO	N	kg

1.3. TERMS AND DEFINITIONS

Some recurring terms found within the manual are described in order to provide a more complete image of their meanings.

- **Routine maintenance.**
Group of functions necessary to maintain suitable machine operations and efficiency. Normally the manufacturer, who defines the necessary skills and intervention procedures, plans these operations.
- **Non-routine maintenance.**
The whole of the operations necessary to keep the operating and efficiency capacity of the machinery. These operations are not scheduled by the manufacturer and must be carried out by the maintenance technician.
- **Operator.**
A person authorised and chosen from those who have the requirements, skills and information necessary for installation, use and ordinary maintenance of the machine.
- **Maintenance technician.**
A person authorised and chosen among those who have the requirements, skills and information necessary to perform ordinary and extraordinary machine maintenance. He is expected, therefore, to possess precise information and skills with particular expertise in the field of intervention.
- **Training.**
training process aimed to transfer to the operator the knowledge, skills and behaviour required to operate the machine autonomously, properly and safely.
- **Installer.**
technician chosen, among those that meet the requisites, and authorised by the manufacturer or by its representative, to install and test the machine or the system in question.
- **Production manager.**
A qualified and skilled technician with experience in the operation and use of machinery in the relevant manufacturing field.
According to the production needs, the Supervisors may use the machine themselves or give the task to another Operator.

1.4. MODES OF REQUESTING FOR ASSISTANCE

The distribution network **ROBOPAC** is at your service for any problem that requires technical support, to order spare parts, and for whatever new type of need that can help develop your business.

Report the data displayed on the ID plate, the estimated hours you have used the machine, and the type of flaw you have uncovered when requesting technical support.

Contact one of our authorized dealers at the listed address for all your needs.

ROBOPAC S.p.A
VIA FABRIZIO DA MONTEBELLO, 81
47892 GUALDICCILOLO, REPUBBLICA S. MARINO (RSM)
Phone 0549 (international ++378) 910511
Fax 0549/908549 - 905946
<http://www.aetnagroup.com>

1.5. ATTACHED DOCUMENTATION

The machine is provided with the documentation listed below, in the absence of a different trade agreement.

- CE statement of conformity.
- Warranty conditions.
- **S.P.E.** battery charger handbook (In Italian and English).
- **NORDELETRONICA** battery charger handbook (Italian, English, French, German, Spanish).
- battery documentation (In Italian and English).
- Manuals of installed commercial devices (if necessary for machine use).
- Instructions for unpacking and installation.
- Quick start guide.
- USB flash drive that contains the information listed.
 - Use and maintenance manual translated into various languages.
 - Spare parts catalogue.
 - Machine programming software.
 - Electrical wiring diagram.

1.6. HOW TO READ THE DIRECTIONS FOR USE

The handbook is divided in chapters, each of which describes a specific category of information.

Each operator who interacts with the machine, apart from reading all the documentation, must read and learn the information concerning his specific qualification.

Refer to the name preceding the title of the chapters, present in the summary, to search for the subjects to consult.

These instructions are the result of an automatic system of assembly of text and illustrations, therefore, it is possible to find, as pages change, some interruptions of the flow of text and charts.

Keep this manual for the entire duration of its useful life in a well known and easy to access place, available for reference any time the need should arise.

Keep the instructions for use and the attached documentation for future consultation.

2. SAFETY INFORMATION

2.1. GENERAL SAFETY PRECAUTIONS

- Carefully read the "Instructions for use" specified in the manual and those applied directly to the machine.
It is important to dedicate a little time to read the "Instructions for use" in order to minimise the risks and avoid unpleasant accidents.
- Before performing any operation, the operator must make sure that he/she understood the "Instructions for use".
- Pay attention to the SAFETY WARNINGS, do not use the machine for UNSPECIFIED PURPOSES and assess the possible RESIDUAL RISKS.
- Caution is essential.
Safety is also in the hands of those who interface with the machine throughout its life span.
Sometimes, accidents can be caused by a "careless" use of the machine by the operator. Usually it is too late to remember what should have been done when the accident has already happened.
- Preserve the readability of the information signs and observe the indications given.
The information signs may have different shapes and colours, indicating hazards, obligations, prohibitions and information.
- The manufacturer has designed the machine observing all the "good manufacturing regulations" and the standards in force.
The machine has been designed to be constructed and equipped with devices that ensure intrinsic safety.
Tampering with the safety devices and the removal of the same may create risks (even severe) for the operators.
- The personnel authorised to carry out any operation with the machine must have acknowledged experience in the specific field.
- **The manufacturer is not responsible for any damage to the product delivered in the package during the wrapping and stabilisation and the following operation phases.**

Non compliance with the instructions given may cause risks for safety and health of the persons and economic damages.

2.2. SAFETY WARNINGS FOR HANDLING AND INSTALLATION

- The personnel authorised to handle the machine (loading and unloading) must possess particular expertise in the field of intervention.
- Handle (load and unload) the machine according to the instructions affixed directly to the machine, to the package and those in the user manual.
- During handling use one or two assistants, if required. This operation may generate unpredictable risks. In order to minimise the risks related to assistants' involvement, you must inform them priorly on the type of work and the behaviour to be used.
- The machine must be handled with the aid of specific means (crane, forklift etc.) by qualified personnel capable of observing the safety requirements.
- When using the lifting means, insert and/or fasten the devices (hooks, forks etc.) ONLY into the points provided on the package and/or the machine.
- Transport the machine suitable means of adequate capacity.
- Make sure the machine and its components are properly fastened to the transport mean.
Check the machine dimensions and affix proper signs if the machine overall dimensions exceed the values allowed by road regulations.
- The minimum and maximum temperature (during transport and/or storage) must fall within the range allowed in order to prevent damaging the electrical components.

- Install the machine in environments (artisan and industrial) with a flat surface that has no bumps so as to move easily round the pallet.
- Dismantle all the packaging components in compliance with the standards in force in the country of installation.

Non compliance with the instructions given may cause risks for safety and health of the persons and economic damages.

2.3. SAFETY WARNINGS FOR USE AND OPERATION

- The operator must be trained and possess the proper knowledge required to carry out the specific tasks and must meet the conditions required for the safe use of the machine.
- When using the machine for the first time, the operator must read the manual and identify the controls and simulate some operations, especially the start-up and shutdown.
- The machinery has been designed and manufactured to satisfy all the operating conditions indicated by the manufacturer.
- The machine shall be used ONLY for the purposes and complying with the procedures specified by the Manufacturer.

Use the machine ONLY with the original safety devices installed by the manufacturer.

- ALWAYS wear the individual safety devices indicated in the "Instructions for use" and provided by the standards in force regarding the safety at workplace.
- Always keep the perimeter spaces in suitable conditions and without obstacles to ensure the machine works correctly.
- The machine must be used by one operator ONLY, that must be assigned and authorised by the employer.

Non compliance with the instructions given may cause risks for safety and health of the persons and economic damages.

2.4. SAFETY WARNINGS RELATED TO INCORRECT USE

Read the next warnings carefully.

2.4.1. INCORRECT USE THAT CAN BE REASONABLY EXPECTED

- The predictable incorrect use consists of: "the use of the machine different from the indications given in the manual, that may stem from the easily predictable human behaviour".

The machine must be EXCLUSIVELY used in order to wrap and stabilise products contained in packs (boxes, containers for liquids, etc.), having a regular shape or a shape that allows for stable palletising.

The packs that contain liquids or insubstantial materials must be suitable for the product and must be perfectly closed and tight in order to prevent any leaks of the content.

- Do not use the machinery with the safety devices not properly installed and efficient.
- DO NOT tamper with, remove or bypass the safety devices installed on the machine.
- DO NOT modify the constructive and functional characteristics of the machine.
- Do not use the machine in spaces exposed to atmospheric agents, corrosive substances or at explosion/ fire risk.
- Do not use the machine as a transportation means for goods or persons.
- Do not use the machine to wrap and stabilise living beings (animals and humans).
- DO NOT wrap products that are loose, that have an irregular shape or that are not suitably collected, to prevent inadequate palletisation.
- DO NOT use the machine with wrapping material different from that provided by the manufacturer.
- Do not over stretch or pre-stretch the film and do not wrap with an excessive number of bindings in order to prevent damaging the packages and products contained inside.
- DO NOT use the machine on uneven or tilted surfaces.
- DO NOT use or let the machine be used for purposes or in ways not provided by the manufacturer.

- DO NOT allow the machine to be used by operators that are not properly trained, informed and unauthorised.
- Do not use the machine as a lifting device or as a rest surface for work activities (for example, a workbench).
- NEVER use the machine if the scheduled maintenance interventions have not been carried out accordingly.
- If troubles arise, do NOT continue to use the machine. Stop it immediately and restart only after restoring the normal operating condition.
- DO NOT carry out interventions different from those indicated in the user manual without the written consent of the manufacturer.
- NEVER carry out an intervention with the machine enabled but ONLY after having stopped it properly, under safety conditions.
- DO NOT clean or wash the machine with aggressive products to avoid damaging the components.
- DO NOT replace the components with non-original spare parts or with different design and constructive features.
- DO NOT leave the machine unattended at the end of the work without shutting it down first in safety conditions.
- DO NOT allow people to walk through or stand within the working area of the machine during the wrapping cycle.

2.4.2. EMPLOYER OBLIGATIONS

- The operator must possess the required training and meet the suitable conditions for carrying out the activities in safety conditions.
- The employer must inform the operator on the INCORRECT USES predictable and on the persistent Residual risks.
- The operator must be capable of reading and understanding the user manual and must easily identify the safety signs.

The employer must draw up the documentation of the specific training carried out by the operators in order to exhibit it in case of litigation.

2.5. SAFETY WARNINGS ON RESIDUAL RISKS

When designing and building the machine, the manufacturer has paid particular attention to the RESIDUAL RISKS that may affect the safety and health of the operators.

The residual risks are: "all the risks that persists although all safety solutions have been applied and integrated during machine design".

The list specifies the residual risks specific for this type of machine.

- **Upper limb cutting hazard**
Do not place hands inside components in motion.

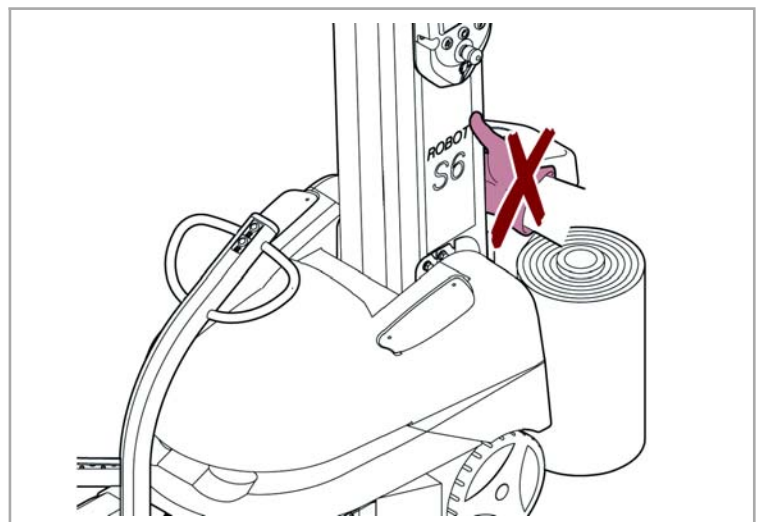

- **Danger of arms crushing**
To close the battery cover, lower it slowly to avoid trapping your hands.

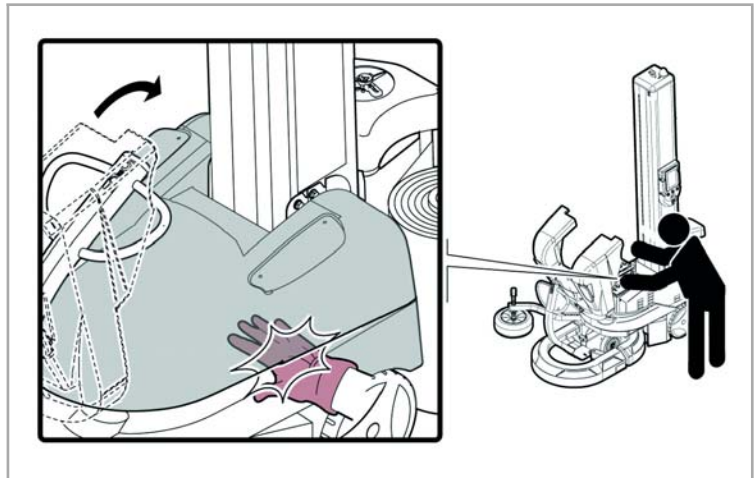

- **Body crushing hazard**
Do not linger in the machine operating area.



- **Body crushing hazard**
Do not linger in the machine operating area.



2.6. SAFETY WARNINGS FOR REGULATIONS AND MAINTENANCE

- Always keep the machine in optimum operating condition and carry out the routine maintenance according to the intervals and procedures specified by the Manufacturer.
A good maintenance will ensure a stable performance over time, longer working life and constant compliance with the safety requirements.
- Enable all machine safety devices before performing any maintenance and regulation operations.
- Delimitate the work area complying with the safety conditions as provided by the standards on workplace safety in order to minimise the risks.
- The maintenance interventions in the areas that are not easily accessible or dangerous must be carried out after having ensured the necessary conditions.
- The personnel authorised to carry out the ordinary maintenance (regulations, replacements etc.) must possess the necessary technical and professional knowledge.
- Wear the Individual Protection Devices provided by the laws on workplace safety and indicated in the "Instructions for use" and/or affixed to the machine.

- Replace the components **ONLY** with **ORIGINAL PARE PARTS** or with **SIMILAR** design and functional features.
The use of similar but non-original spare parts may lead to improper repairs, altered performance and economic damage.
The components and/or safety devices shall be replaces ONLY with original spare parts to avoid altering the provided safety level.
- Use lubricants (oils or grease) recommended by the manufacturer or with similar chemical-physical features.
- Do not dump into the environment polluting liquids, worn parts and maintenance waste.
- Select the components according to the chemical and physical features of the material and carry out the differentiated waste disposal as per the standards in force.
- All the extraordinary maintenance interventions shall be carried out **EXCLUSIVELY** by authorised personnel with particular expertise in the field of intervention.
Non compliance with the instructions given may cause risks for safety and health of the persons and economic damages.

2.7. SAFETY WARNING FOR ELECTRICAL EQUIPMENT

The electrical system has been designed and built in compliance with applicable legislation. This legislation also specifies the ambient conditions required for operation.

The following list specifies ambient conditions necessary to ensure correct electrical system function.

- Ambient temperature must be between **5°C** and **40°C**.
- Relative humidity must be between **50%** (measured at **40°C**) and **90%** (measured at **20°C**).
- The installation area must not be subject to or contain sources of electromagnetic interference or radiation (X rays, laser light etc).
- The installation area must not contain potentially explosive or flammable mixtures of gases or dust.
- No contaminant or corrosive products (acids, chemicals, salts etc.) may be used during production and maintenance. Any products used must be kept away from electrical components.
- The ambient temperature during storage must be between **- 25°C** and **55°C**.
- Electrical equipment may be exposed to temperatures up **70°C**, provided that exposure does not exceed **24** hours.
- The electrical system will function correctly up to an altitude of **1000 m** above sea level.

If any of the aforementioned conditions cannot be met, any additional measures necessary to ensure safe operating conditions (e.g. special electrical components, air conditioning systems etc.) must be defined during the contractual stage.

2.8. INFORMATION AND SAFETY SIGNALS

The figure indicates the position of the safety and information signs affixed to the machine.

For each sign is specified the relative description.

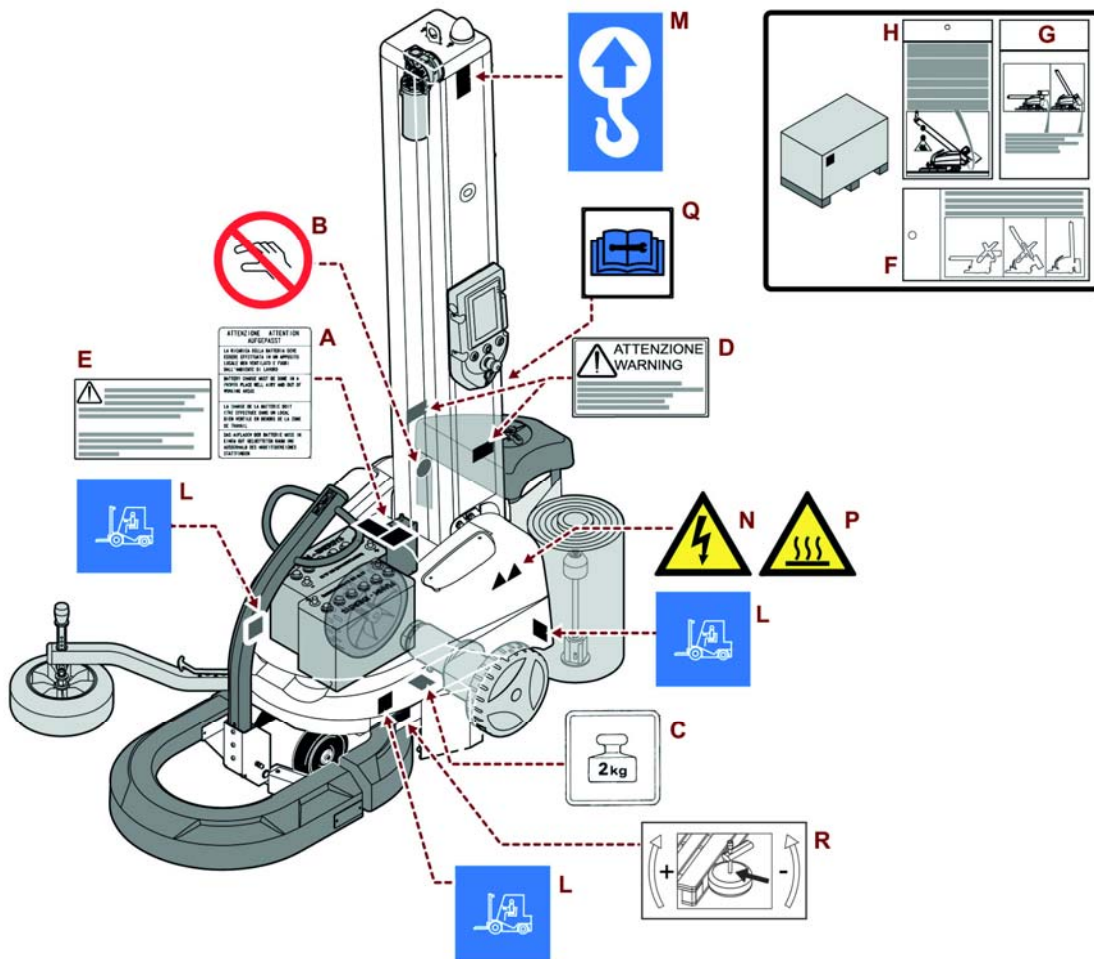

- A)** Information sign: It indicates that the “the battery should be charged in a suitable and well-ventilated environment, outside the working area”.
- B)** Prohibition sign: Do not use your hands to intervene on the component.
- C)** Information sign: It specifies the weight of the component.
- D)** Warning signal: Indicates the screws that should be fastened after the column is lifted.
- E)** Information sign: It indicates that the batteries must be charged after a prolonged period of inactivity.
- F)** Information sign (applied during the transportation phase): It informs about the hazards and provides instructions on how to prepare the machine for use after the transportation phase.
- G)** Information signal (applied during transport): Indicates how to remove the package from the machine.
- H)** Information signal (applied during transport): Indicates column lifting conditions.
- L)** Information signal: indicates the lifting points with a fork device.
- M)** Information sign: it indicates the points where to attach the hooks of the lifting device.
- N)** Electrical hazard warning sign: do not enter area to avoid hazards of electrical shocks or electrocution.
- P)** Hazard sign: Do not touch the area to avoid the risk of burns.
- Q)** Carefully read the manual before carrying out any type of work.
- R)** Adjustment signal: indicates how to adjust the feeler thrust. (Optional).



Important

Check that the plates are clearly readable, and, if necessary, replace them with new ones that shall be positioned in the same places as previously.

2.9. SURROUNDING AREAS

The illustration depicts the perimeter work areas of the machine.

- A) Machine's operating area.
- B) Surrounding area.

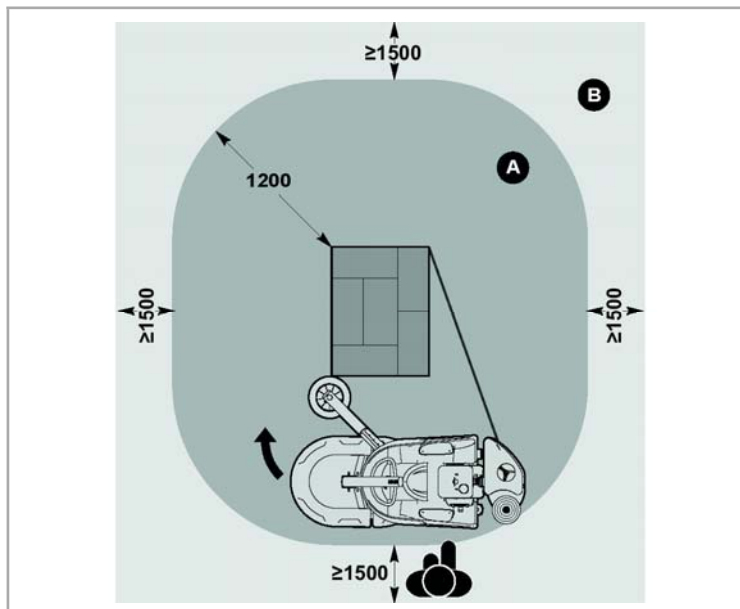

3. TECHNICAL INFORMATION

3.1. MACHINE GENERAL DESCRIPTION

- The **S6**-series ROBOT is a semiautomatic self-propelled machine designed to wrap and stabilize palletized loads using a stretchable film.
- The machine is suitable for installation in workshops and factories, protected against weather conditions. The installation surface must be plane and even, to allow the machine to easily move around the pallet.
Just one operator is required to bring the machine close to the pallet, tie the film, carry out the cutting at the end of the wrapping and resupply the reel.
- **If the machine is equipped with an automatic cutting device, the film is automatically cut at the end of each wrapping cycle.**
- The loads are wrapped using reels of stretchable film which can be readily found on sale.
- The machine must be **EXCLUSIVELY** used in order to wrap and stabilise products contained in packs (boxes, containers for liquids, etc.), having a regular shape or a shape that allows for stable palletising.
- The packs that contain liquids or insubstantial materials must be suitable for the product and must be perfectly closed and tight in order to prevent any leaks of the content.
- The machine is equipped with a series of safety devices designed to avoid any harm befalling the operator or other persons who come into contact with the machine in any way.
- The machine frame is provided with special points (right-hand & lefthand sides and column side) for the handling with a forklift device.
- **Use of this machine in explosive environments or when exposed to the elements is strictly forbidden.**
- The machine is manufactured in various models to satisfy the different market requirements.

The following list provides a description of the main components and their functions.

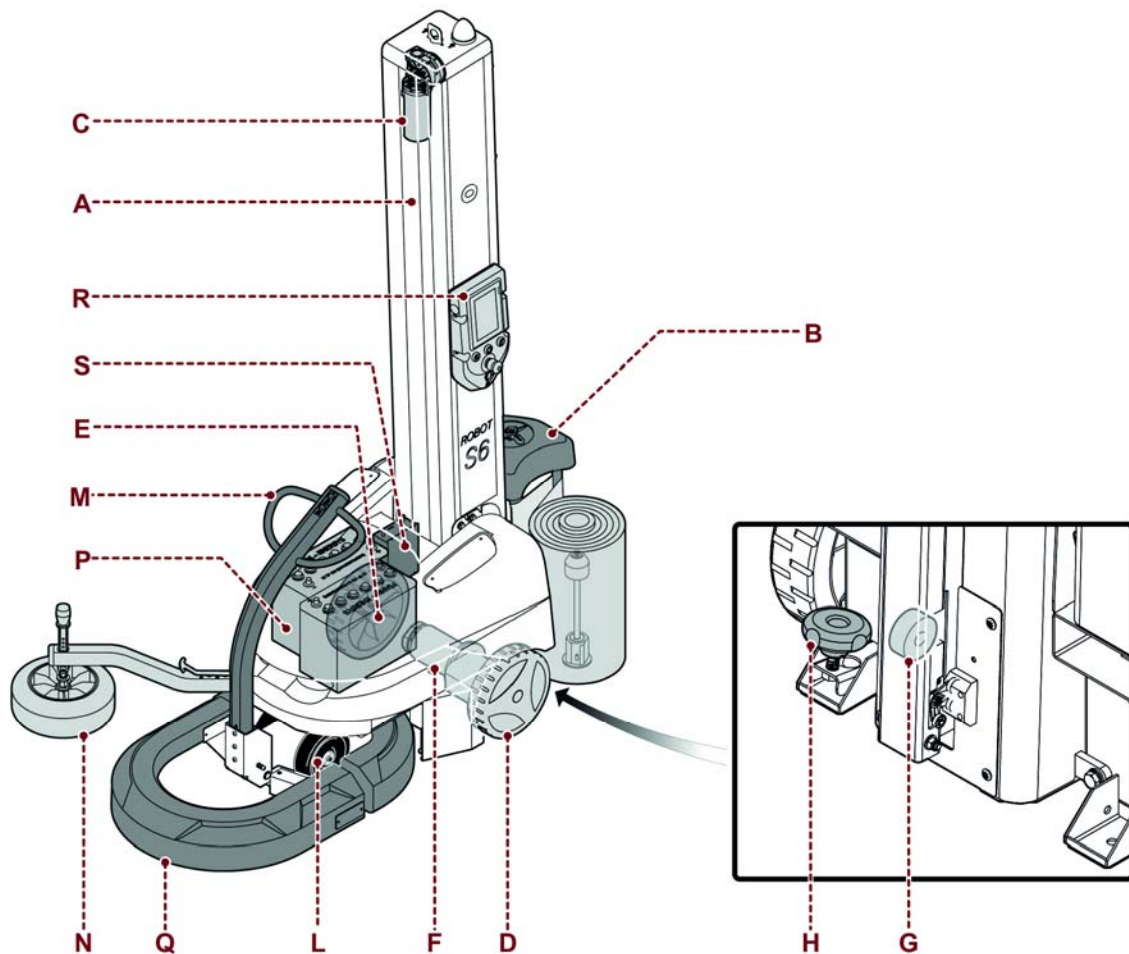

- A)** Slide column: for the vertical handling of the reel carriage.
- B)** Roll-holder carriage: It includes a series of stretching and prestretching devices.
For further details refer to the table "Roll-holder Carriage Specifications".
The vertical movement is controlled by the gearmotor (**C**), operated by an electric motor powered by the batteries (**P**).
- D)** Driving wheel: It is operated by the electric motor (**F**), powered by the battery (**P**). This wheel is equipped with an electromagnetic brake.
The electromagnetic brake stops the driving wheel when the battery power is turned off due to a fault (e.g. upon a component failure) or when the machine is stopped (upon an emergency or a cycle stop).
When the driving wheel is locked, the machine can be moved only over short distances using the small backup wheel (**G**).
- E)** Idle wheel: It is installed in line with the driving wheel (**D**).
- G)** Backup wheel: By turning the handwheel (**H**), the backup wheel allows detaching the locked driving wheel (**D**) from the ground, in order to be able to move the machine over short distances.
- M)** Tiller: It is equipped with leading wheels (**L**) and is used to manually move the machine.
- N)** Feeler wheel: Its purpose is to follow the perimeter of the pallet during the wrapping cycle.
- P)** Batteries: They provide power supply to the electric motors and the circuit.
- Q)** Safety bumper: In case of collision, this safety device stops the machine.
For further details consult the paragraph "Description of safety devices".
- R)** Control panel: It is equipped with electromechanical controls and a touch-screen display for the programming of the wrapping parameters.
- S)** Battery charger: is electronic and is used to recharge the batteries.

3.1.1.ROLL-HOLDER CARRIAGE SPECIFICATIONS

Type of reel holdingcarriage	General Requirements
FRD	FRD and "FRD for net" type reel carriage; with friction roller, mechanical brake and manual film stretch adjustment.
FR	FR type reel carriage with friction roller, electromagnetic brake and film stretchadjustment from the control panel.
PDS	PDS-type spool carriage; with driven pre-stretch rollers and electronic film tensioning. Pre-stretching is adjustable from control panel (0%÷250%).
PVS	PVS type reel carriage: with dual drive pre-stretch rollers and electronically controlledfilm tensioning. Pre-stretching is adjustable from control panel (0%÷400%).

3.2. OPERATING CYCLE AND WRAPPING MODES

The figure below shows the operating cycle. A brief description and illustration of the wrapping modes (single and double) are also provided.

3.2.1.RUNNING CYCLE

- **Phase 1**
The Operator approaches the machine until the feeler wheel is in contact with the pallet, then ties the end of the film to the pallet and starts the wrapping cycle.
- **Phase 2**
The machine turns clock-wise around the pallet, while the roll-holder carriage lifts and releases the film according to the parameter settings.
- **Phase 3**
Upon completion of the wrapping phase, the machine stops. After cutting the film (manually or in automatic mode) the machine can be moved to the following pallet to be wrapped.

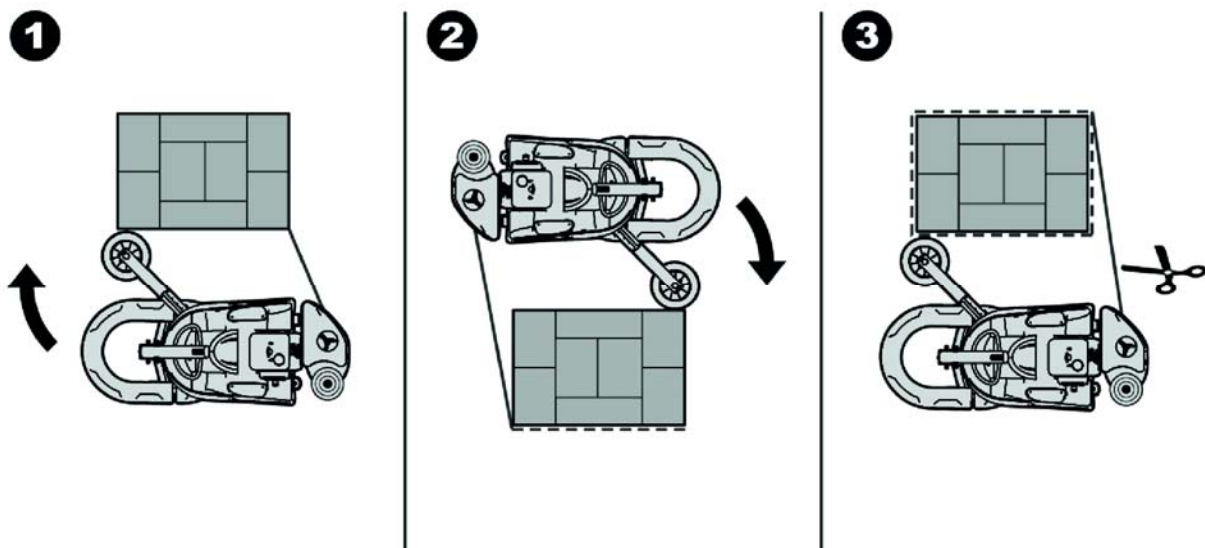

3.2.2.MODES OF WRAPPING

- Single wrapping: It starts at the base of the pallet with a series of stabilizing windings and then stops at the top of the pallet with a closing winding. To start a new wrapping phase from the base, the roll-holder carriage must be lowered using the manual controls.

1) Start
2) STOP

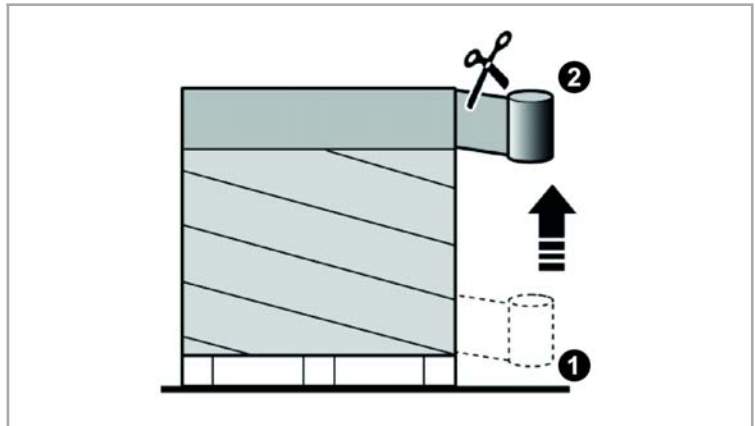

- Double wrapping: the base of the pallet with a series of stabilizing windings and then reaches the top of the pallet. After performing a reinforcement winding at the top, the wrapping process continues back to the bottom and stops after performing the closing winding.

1) Start
STOP

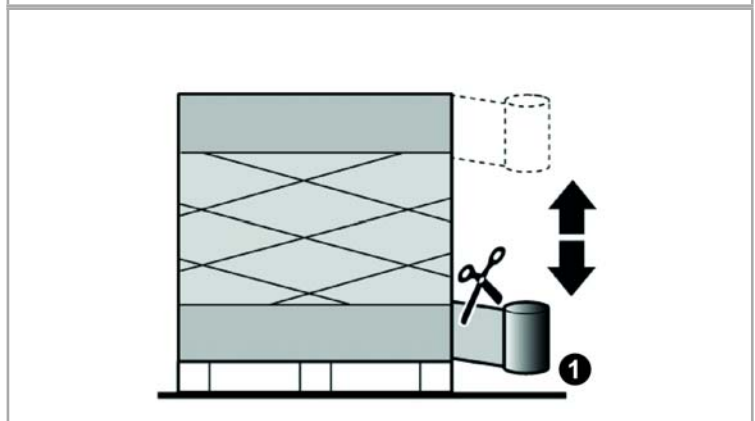

- Double wrapping with sheet feeder: It starts at the base of the pallet with a series of stabilizing windings and temporarily stops at the top of the pallet. After the protection sheet (**TOP**) has been put in place, the Operator resumes the wrapping cycle. After performing a reinforcement winding at the top, the wrapping process continues back to the bottom and stops after performing the closing winding.

1) Start
STOP
2) Start
STOP

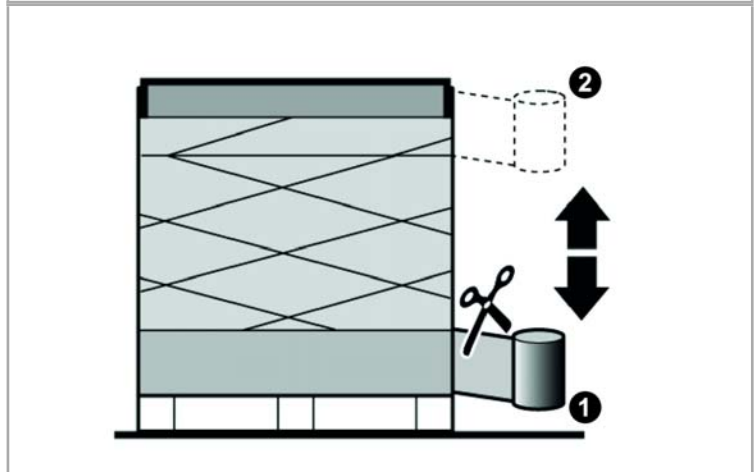

3.3. SAFETY DEVICE DESCRIPTIONS

The figure shows the position of the safety devices, whose description and function is provided in the following list.

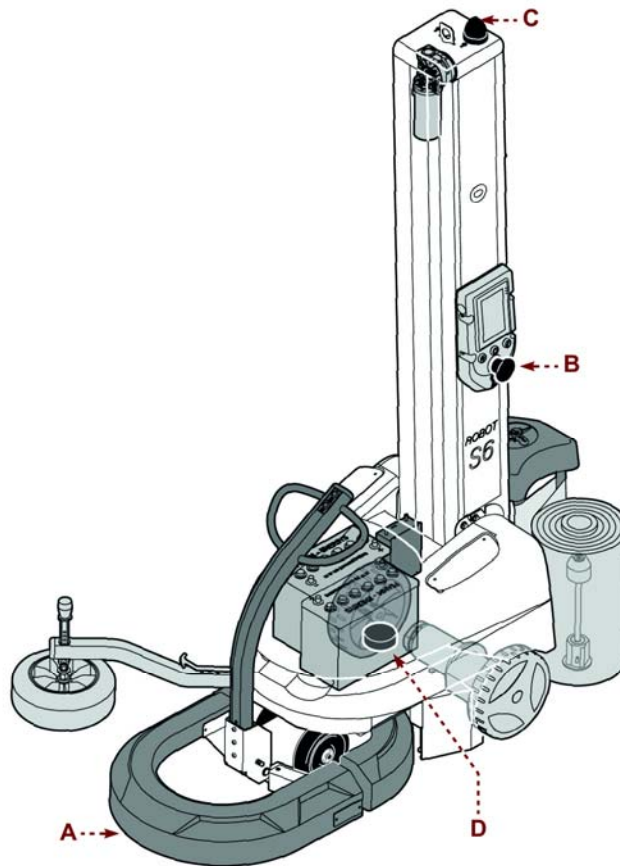

- A)** Safety bumper: In case of collision against an obstacle, it stops the machine run and the wrapping cycle.
To reset the machine, remove the obstacle, cut the film and press the control.
When the roll-holder carriage has reached its starting position, restart the machine to repeat the wrapping.
For further details, see paragraph "Wrapping Start and Stop".
- B)** Emergency stop push-button: it is used to stop with a voluntary action, in case of imminent risk, the organs of the machine that may pose a risk.
The control must stay "locked" until all the normal operating conditions have been restored.
Restore the normal operating conditions, cut the film, unlock the button and press the control to reset the machine.
When the roll-holder carriage has reached its starting position, restart the machine to repeat the wrapping.
For further details, see paragraph "Wrapping Start and Stop".
- C)** Light indicator (orange light): It indicates that the machine is running.
- D)** Acoustic warning: It warns that the wrapping cycle has started.

3.4. DESCRIPTION OF THE ELECTRICAL DEVICES

The figure shows the positioning of the devices on board of the machine.

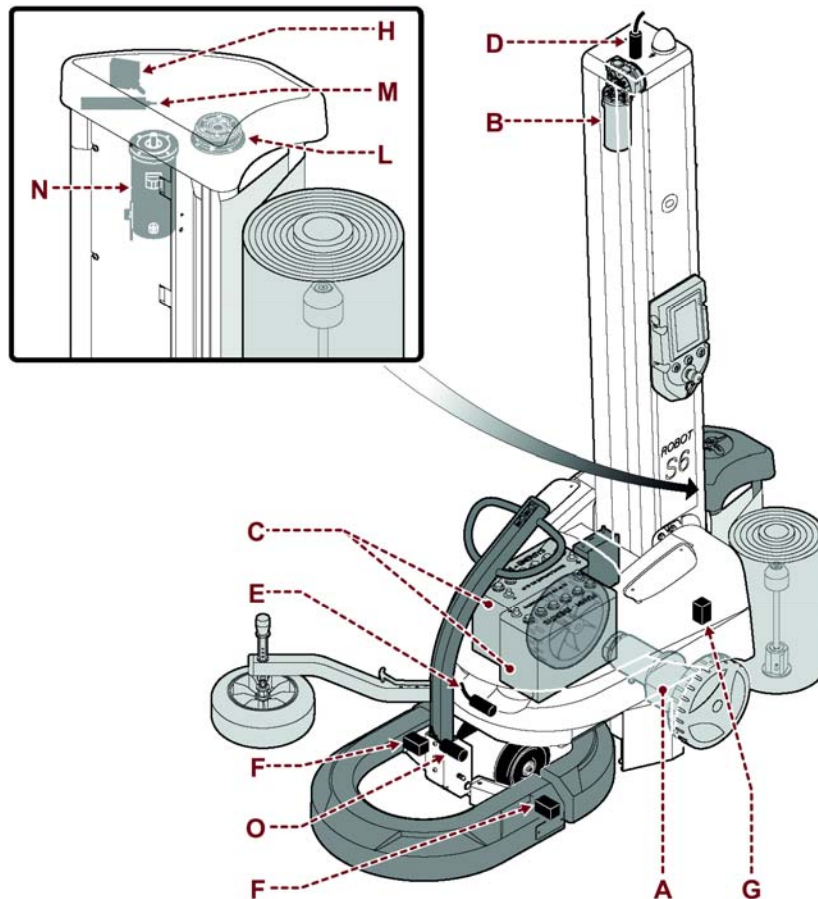

- A)** Electric motor: it activates the driving wheel.
- B)** Gear motor: activates movement of the spool carriage.
- C)** Batteries: They provide power supply to the electric motors and the circuit.
- D)** Sensor: it is equipped with a phonic wheel and it detects the drive speed of reel holding carriage.
- E)** "Corner counting" sensor : counts the number of wrapping turns carried out.
- F)** Micro-switch: it starts and enables the stop of the machine movement when the bumper impacts against an obstacle.
- G)** Carriage limit stop microswitch: activates when the reel carriage reaches the minimum and maximum wrapping height.
- H)** Photocell: detects the presence and the height of the load to be wrapped.
- L)** Electro-magnetic clutch: it activates and deactivates the prestretch roller to keep film tightening constant.

Information valid only for reel carriages of type "PDS".

- M)** 'Load cell' sensor: it detects the tension of the film and enables the speed variation of the pre-stretching rollers.
- N)** Electric motor: it drives the pre-stretch rollers.
- O)** "Rudder down" sensor : detects the rudder in a low position.



Important

For further details see the electrical diagram.

3.5. DESCRIPTION OF ACCESSORIES ON REQUEST

To enhance the performance and to increase the versatility of the machine, the manufacturer furnishes the accessories listed below.

- Non-stain wheels:
wheels made of a material that reduces stain formation on the floor.
- Additional Battery kit: it is equipped with a recharging device, two batteries and two baskets for containing batteries.
The kit allows replacing the flat battery holder with the charged battery holder, to minimize the machine downtime.
- Roll-holder shaft: It allows using film rolls with a different diameter with respect to the standard one.
- Reel holding carriage "**FRD** for net":
carriage for winding the pallet with a net film.
- Automatic cutting device: it cuts the film automatically at the cycle end.
- Photocell for black products: It offers a degree of sensitivity capable of detecting the height of pallets with prevailing black surfaces.
- Side guide masts (increased): permit wrapping heights up to **2400 mm**, **2800 mm** and **3100 mm**.
- Double feeler wheel (**ø260÷400**): It is suitable for wrapping the pallets where the product protrudes from the outer perimeter in an irregular way.
- Sensing arm with a larger wheel (**ø400**): suitable for wrapping pallets whose product is not compact.
- Film breakage sensor: detects broken film and empty reel.
- Lightened rudder: allows the operator to move the machine manually with less effort. Also allows the thrust of the feeler wheel to be adjusted more easily.
- Reel trolley with height **750 mm**: allows the use of reels with height **750 mm** (only for certain markets).
- Battery charger with rapid charging: allows the batteries to be charged in about **10** hours (this value depends on the state of the batteries).
- Battery charger with marking **UL/CSA**: only for certain markets.
- Film height adjuster - creasing device:
The device has a double function during the wrapping of the packaging, it can be used to adjust the height of the film (height adjuster) or to tighten the film and form a reinforcement rope for the packaging.

3.6. TECHNICAL SPECIFICATIONS

The figure and table specify the dimensional characteristics and technical data of the machine.

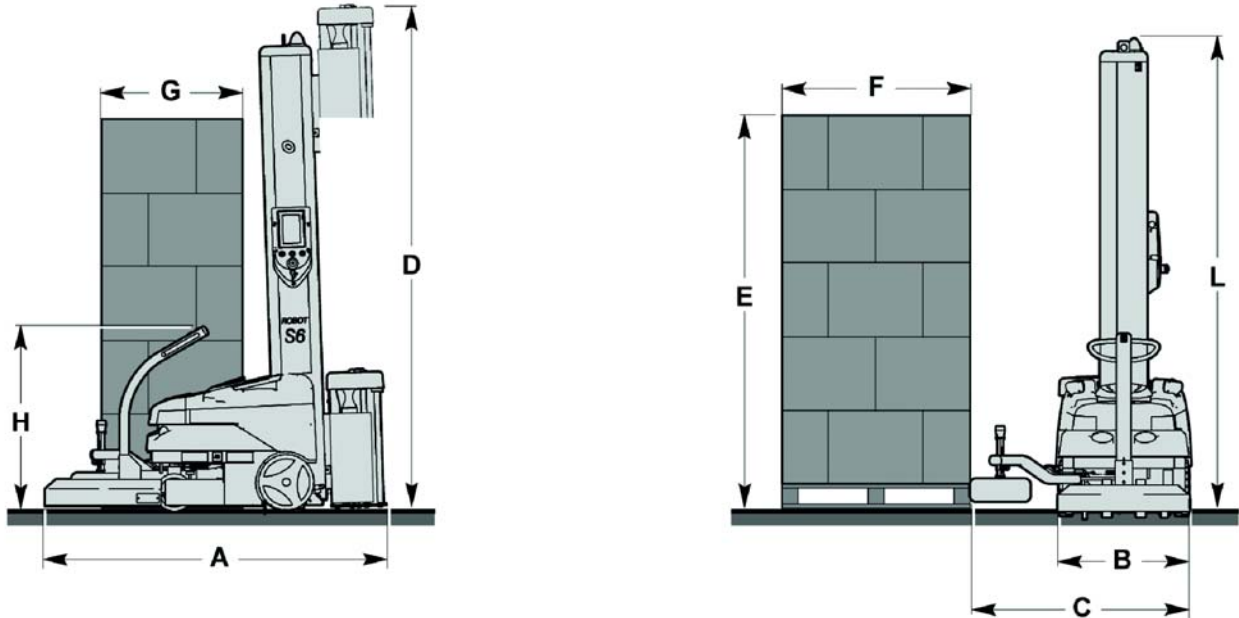

3.6.1. MACHINE AND PALLET DIMENSIONS

Description	Units of measurement	FRD	FR	PDS	PVS
Total machine length (A)	mm	1825			
Machine width (B)	mm	722			
Machine width (C) with feeler wheel open	mm	1183			
Tiller height (H)	mm	984			
(FxG) Pallet dimensions	mm	≥ 800			

Standard version

Pallet height (E)	mm	2200			
Max. machine height (D)					
(E) max = 2200	mm	2580	2630	2630	2805
Sliding column max. height (L)					
(E) max = 2200	mm	2556			

Optional version

Pallet height (E)	mm	2400			
	mm	2800			
	mm	3100			
Max. machine height (D)					
(E) max = 2400	mm	2780	2830	2830	3005
(E) max = 2800	mm	3180	3230	3230	3405

(E) max = 3100	mm	-	-	3430	3605
Sliding column max. height (L)					
(E) max = 2400	mm	2756			
(E) max = 2800	mm	3156			
(E) max = 3100	mm	3356			

3.6.2. TECHNICAL FEATURES

Description	Units of measurement	FRD	FR	PDS	PVS
Lead-acid batteries	n.	2 12V 110 Ah (capacity referred to a 5 h consumption)			
Infeed speed	m/min	35÷80			
Carriage up/down speed	m/min	1,5÷5 ¹			
Total weight (Standard version)	kg	345	340	365	370
Pallet min. weight	kg	45			
Ambient operating temperature	°C	5÷40			

¹ 2÷7,5 m/min with reel height **750 mm**.

3.6.3. BATTERY CHARGER S.P.E.

Description	Units of measurement	FRD	FR	PDS	PVS
Supply voltage	Vac	100-240 +/-10% 1Ph			
Electrical supply frequency	Hz	50/60			
Installed power	kW	0,3 ¹			
Absorption	A	4 (100 V) ² 1,7 (240 V) ³			

¹ **0,4 kW** battery charger for rapid charging.

² **4,3 A (100 V)** battery charger for rapid charging.

³ **1,8 A (240 V)** battery charger for rapid charging.

3.6.4. BATTERY CHARGER NORDELETRONICA

Description	Units of measurement	FRD	FR	PDS	PVS
Supply voltage	Vac	100 - 240 +/-10% - 1Ph			
Electrical supply frequency	Hz	50/60			
Installed power	kW	0,4			
Absorption	A	5 (100 V) 2 (240 V)			

3.7. COIL TECHNICAL SPECIFICATIONS

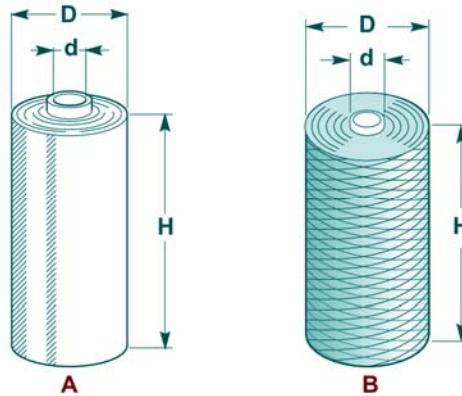

3.7.1. REEL FEATURES

Description	Units of measurement	Value
Film spool dimensions (A)		
Maximum external diameter (D)	mm	300
Reel height (H)	mm	500
Film thickness	µm	17÷35
Internal diameter (d)	mm	50 ¹ - 76
Max weight	kg	20
Net spool dimensions (B)		
Maximum external diameter (D)	mm	300
Reel height (H)	mm	500
Internal diameter (d)	mm	76
Max weight	kg	20

¹ Install the roll-holder shaft provided as an optional.

3.8. NOISE LEVEL

The noise levels were measured in compliance with the standards:

- **ISO 4871**
- **ISO 11201**

Description	Measured level of A weighted emission sound pressure, in the operator position (LpA)
Functioning in working conditions.	66,5 dB (A)



Caution - Warning

Prolonged exposure over **80 dB (A)** may cause health problems. The use of appropriate protection systems is recommended (headphones, ear plugs, etc.).

3.9. INSTALLATION ENVIRONMENT CHARACTERISTICS

Careful consideration must be given to the place where the machine is to be installed, in order to ensure that it may be easily operated, without creating any unnecessary risks for personnel.

Therefore we suggest the following prerequisites:

- suitable room temperature (See "technical specifications").
- A suitably aired place so that when the machine is working, the degree of humidity is not unpleasantly high/low from the point of view of the operator.
- A sufficient lighting in order that a pleasant, relaxing working environment is created for the operator.
- a boundary area that must be left around the machine for safety reasons (See "surrounding areas").
- a flat surface, steady and without vibrations with adequate weight supporting capacity, also in consideration of the palletised loads to be wrapped.
- The area should have adequate outlets for the distribution of both the compressed air and electricity.



Danger - Warning

Use of this machine in explosive environments or when exposed to the elements is strictly forbidden.

4. INFORMATION ON HANDLING AND INSTALLATION OPERATIONS

4.1. RECOMMENDATIONS FOR HANDLING AND LOADING

- Before performing any operation, the authorised operator must make sure that he/she understood the "Instructions for use".
- Carefully read the "Instructions for use" specified in the manual and those applied directly to the machine and/or the package.
- Provide suitable safety conditions in compliance with the regulations on workplace safety to prevent and minimise the risks.
- Pay attention to the **SAFETY WARNINGS**, do not use the machine for **UNSPECIFIED PURPOSES** and assess the possible **RESIDUAL RISKS**.

4.2. PACKAGING AND UNPACKING

The packing is realised, keeping the overall dimensions low, also in consideration of the transport chosen.

To facilitate transport, shipping can be performed with some components disassembled and appropriately protected and packaged.

Some parts, especially electric equipment, are protected with anti-moisture nylon covers.

The cases are marked with all necessary information for loading and unloading.

During unpacking, check the integrity and exact quantity of components.

Packaging material should be appropriately disposed according to the laws in force.

The figures show the most common types of packages.

Packaging on pallet with protective nylon

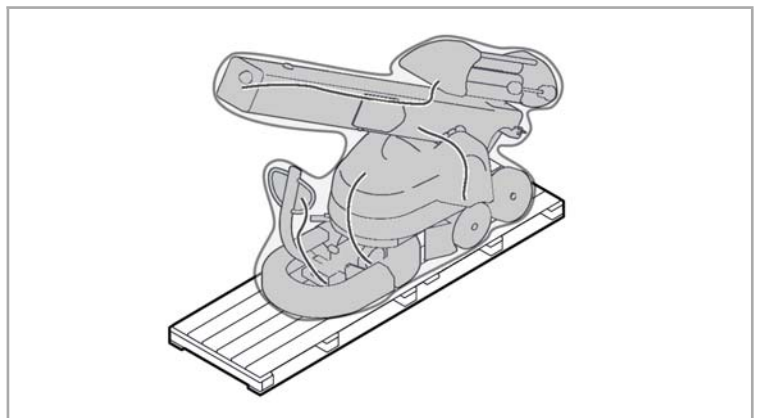

Package in crate

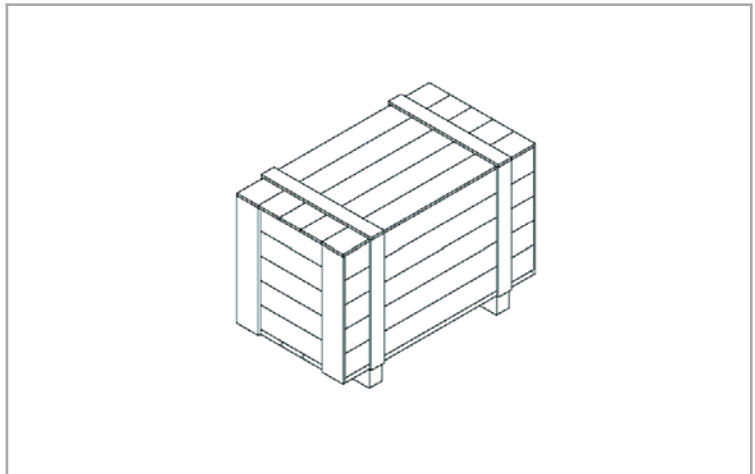

Cardboard box packaging

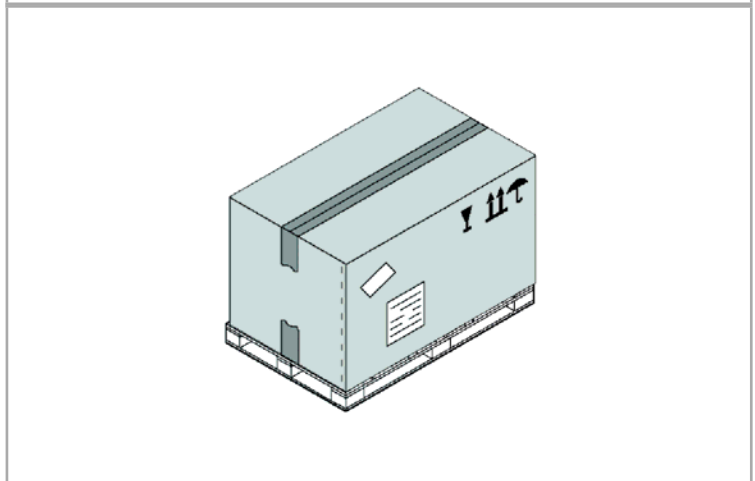

4.3. LOADING AND TRANSPORTATION

Transport, also according to the destination, can be performed by different vehicles. The diagram represents the most popular solutions.

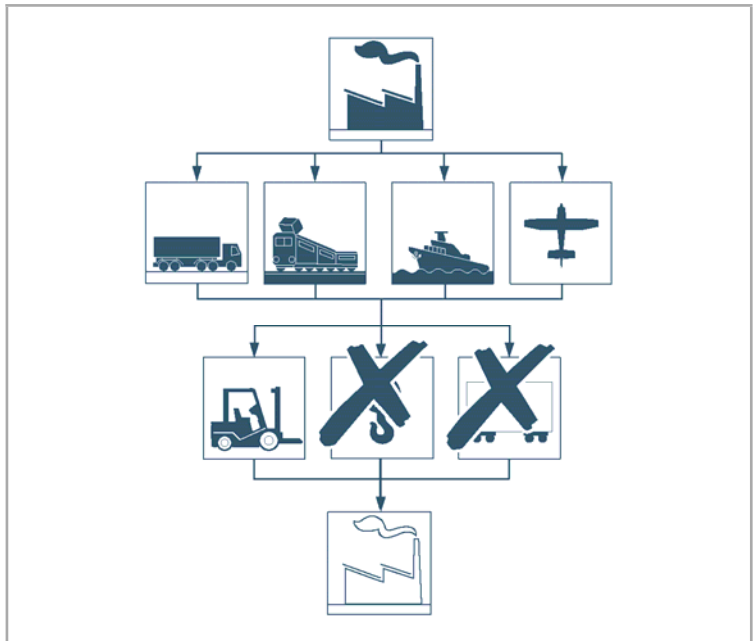

Important

Transport the machine suitable means of adequate capacity.
Make sure the machine and its components are properly fastened to the transport mean.

4.4. INSTALLATION OF DISMOUNTED PARTS

Proceed as indicated.

4.4.1. INSTALLATION (WITH TILTED COLUMN)

1. Fasten the lifting device to the eyebolt **(A)** to keep the column in position.
2. Remove the support **(B)**.
3. Lift the column **(C)**.
4. Tighten the clamping screws **(D-E)**.
5. Tighten the fixing screws **(F)** of the hinge.
6. Release the lifting device.

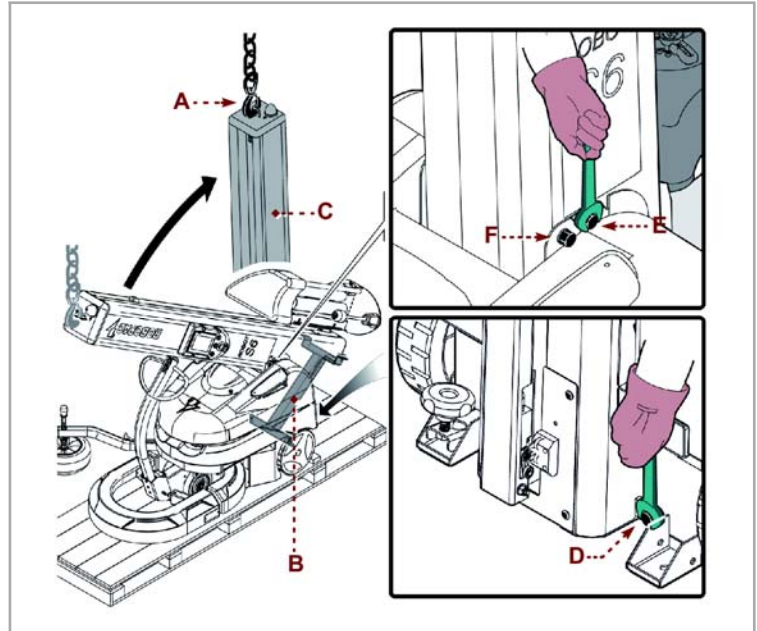

4.4.2. INSTALLATION (WITH HORIZONTAL COLUMN)

1. Connect lifting device to eyebolt **(A)** and lift column **(C)**.
2. Tighten the clamping screws **(D-E)**.
3. Tighten the fixing screws **(F)** of the hinge.
4. Release the lifting device.

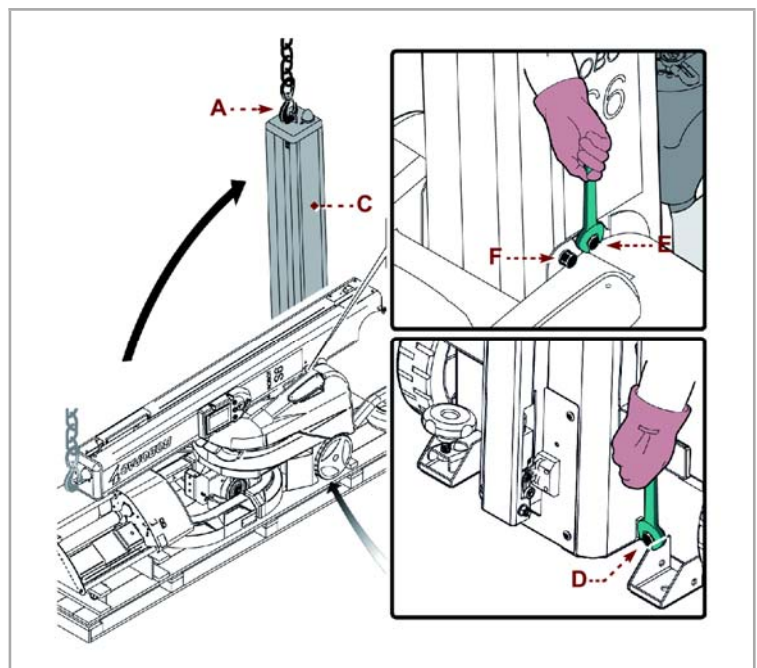

5. Hook the lifting device to the roll-holder carriage (**G**).
6. Lift the roll-holder carriage (**G**) and bring it close to the column, then secure it with the screws (**H**).
7. Remove casings (**L**).
8. Connect the electric connectors to the terminal board of the roll-holder carriage.
9. Reassemble body cover (**L**).

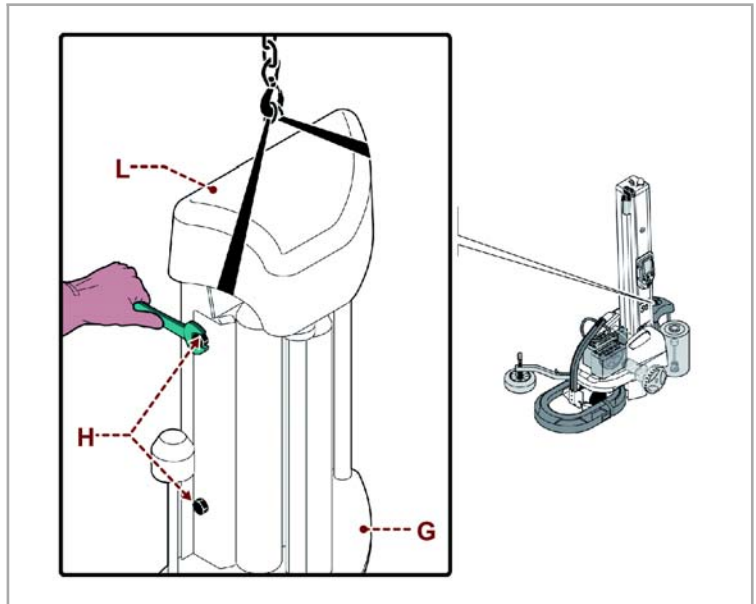

4.4.3. INSTALLATION OF THE WHEEL FEELER AND TILLER

1. Lift and take out the rudder (**M**) from the machine.

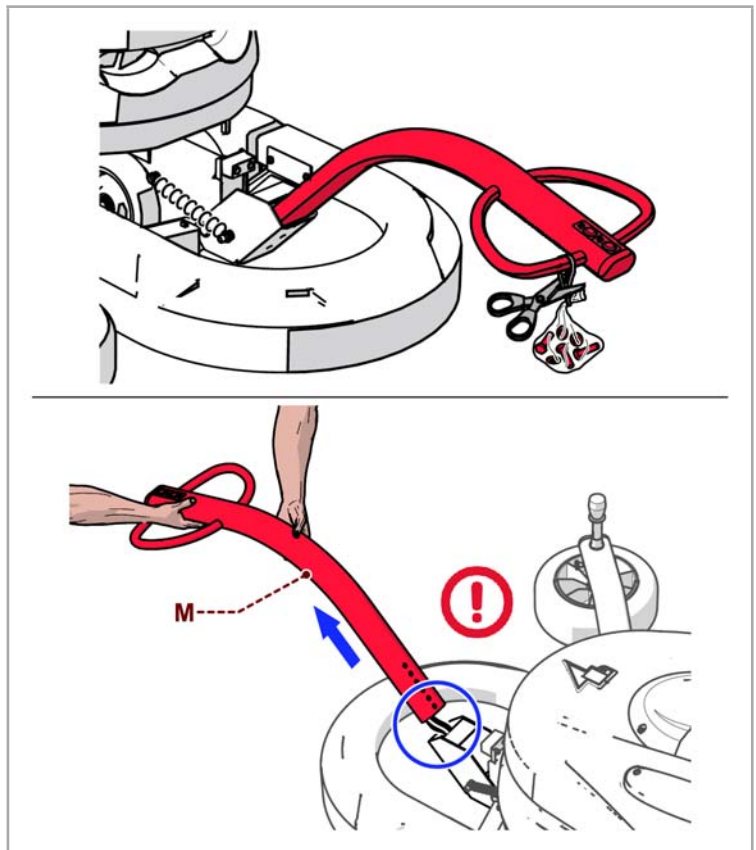

2. Turn the rudder (**M**), connect the connectors (**R**) and insert it into the machine's support.
3. Lift the rudder (**M**) and fix it with the screws (**N**).

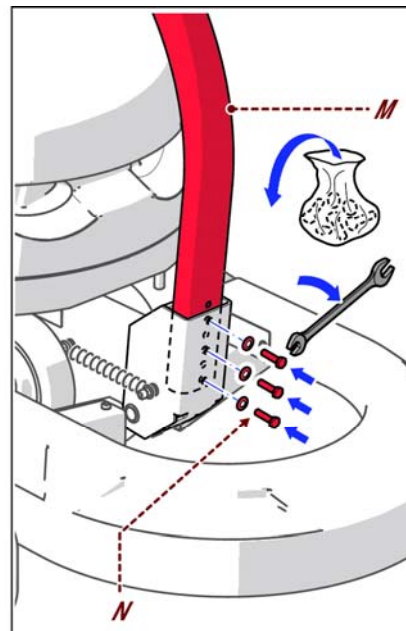
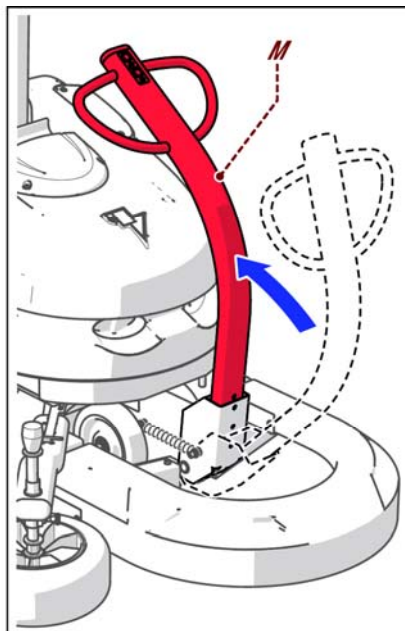
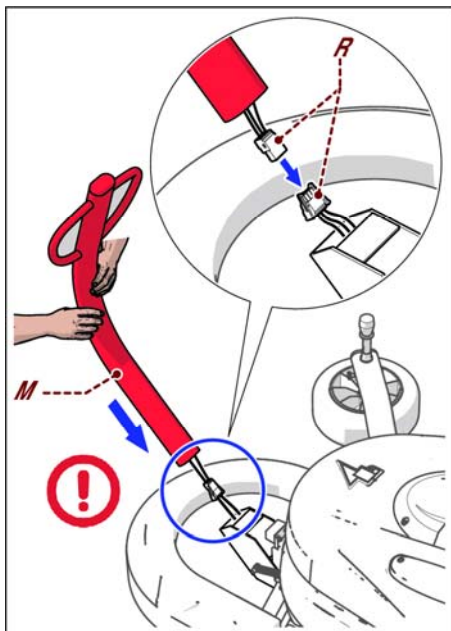

4. Assemble the wheel feeler (**P**) and secure it with the screws (**Q**).

Important

To install the rudder and the feeler, use the nuts and bolts supplied with the machine.

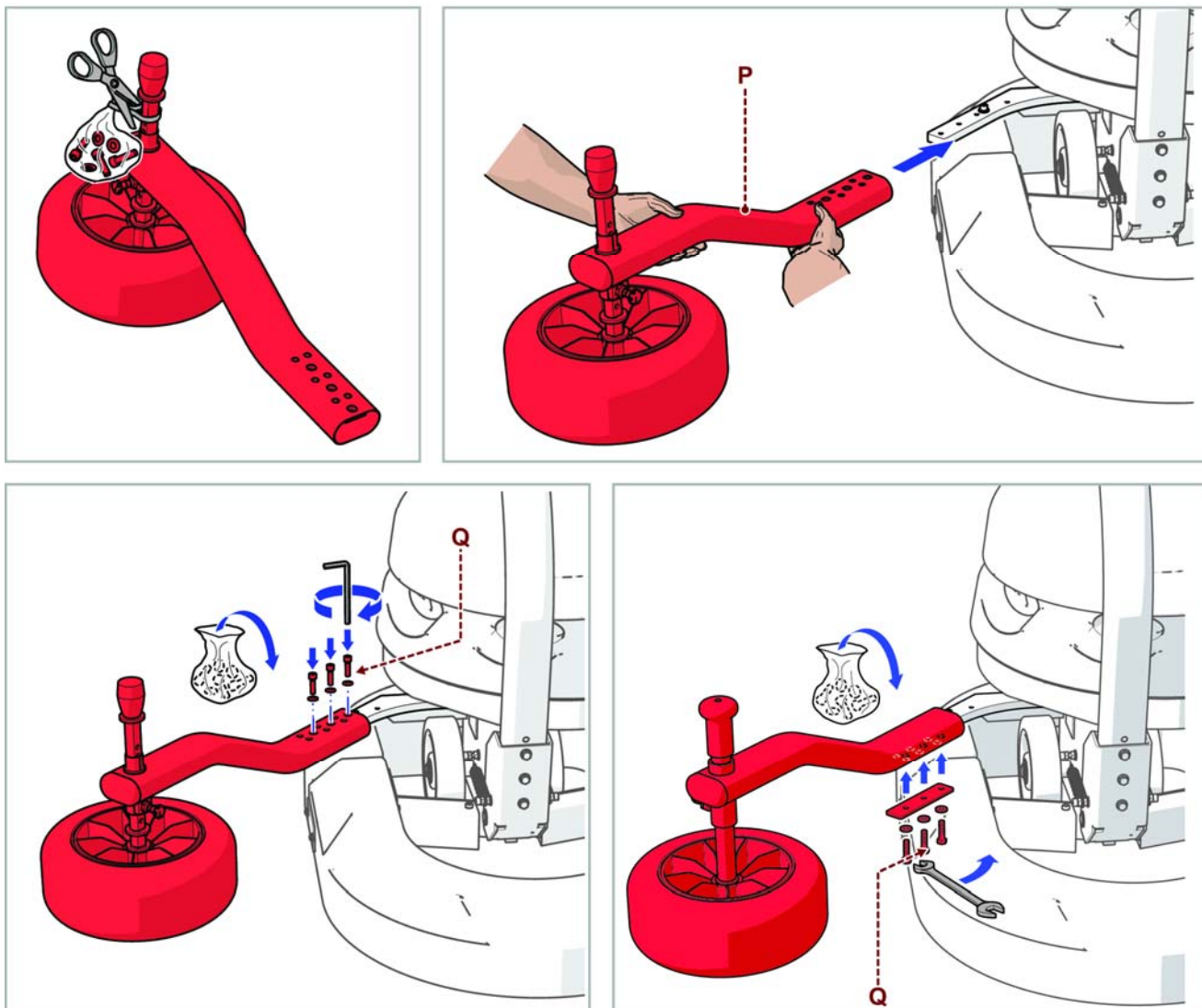

4.4.4. INSTALLATION OF RUDDER WITH LIGHTENED STEERING WHEEL (OPTIONAL)

1. Repeat the operations, mentioned in paragraph "Installation of the feeler and of the rudder".
2. Attach the rope (S) to the sheet metal (T).

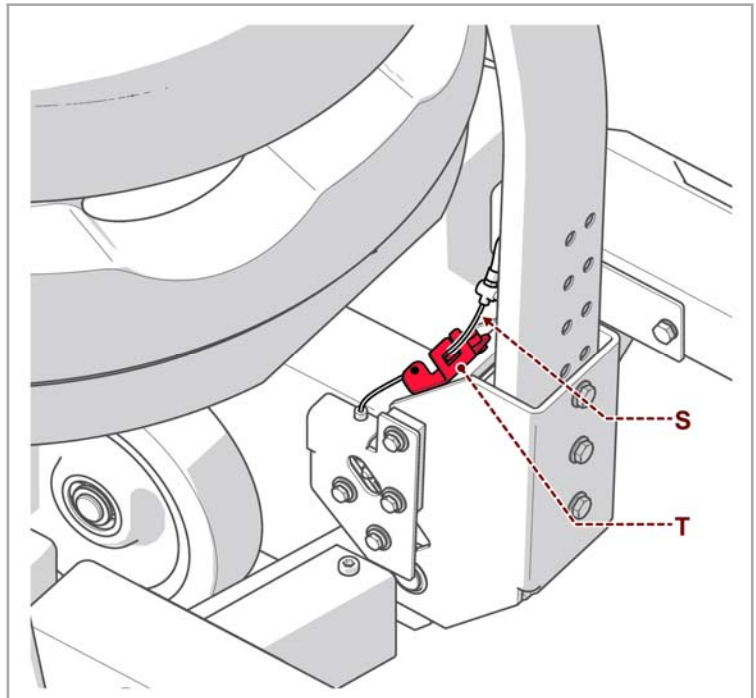

Important

To lower the rudder (V) pull the handle (U).

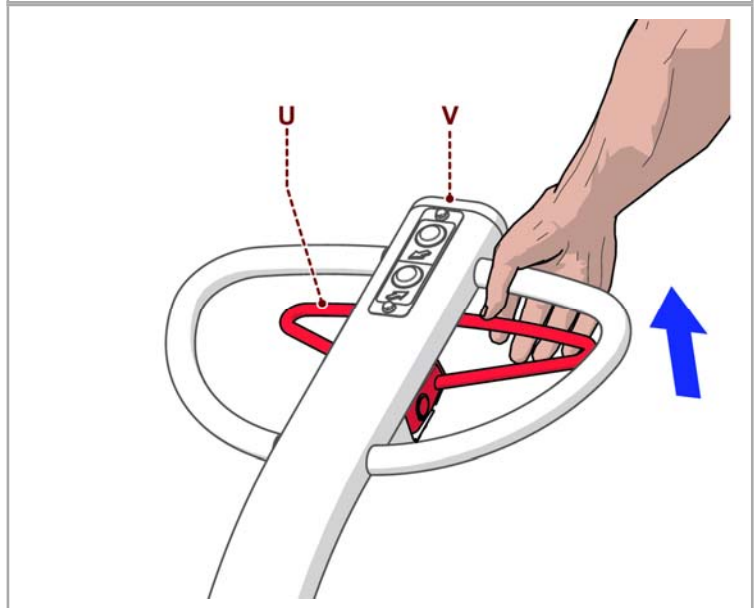

5. INFORMATION ON ADJUSTMENTS

5.1. RECOMMENDATIONS FOR ADJUSTMENTS

- Before performing any operation, the authorised operator must make sure that he/she understood the "Instructions for use".
- Before carrying out any intervention, activate all the safety de-vices provided, stop the machine and assess if any residual energy is still present.
- Provide suitable safety conditions in compliance with the regulations on workplace safety to prevent and minimise the risks.
- Pay attention to the **SAFETY WARNINGS**, do not use the machine for **UNSPECIFIED PURPOSES** and assess the possible **RESIDUAL RISKS**.

5.2. ADJUSTING FILM "STRETCH"

"FRD" type reel carriages.

1. Use lever **(A)** to lock and unlock roller **(B)**.
2. Adjust hand wheel **(C)** to regulate the braking effect of the pre-stretch roller **(B)** that determines film lengthening.

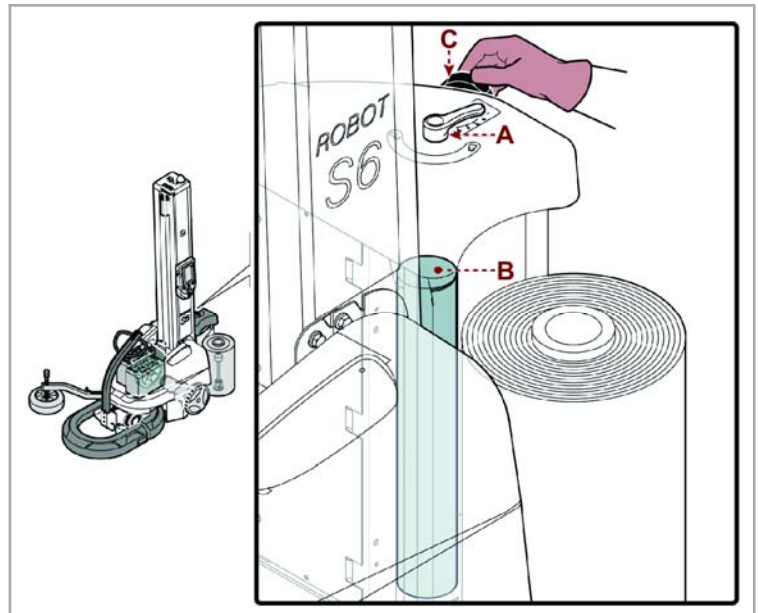

5.3. "FRD TYPE SPOOL CARRIAGE" FORNET

Adjust handwheels **(C-D)** to regulate the braking effect of the prestretch rollers **(E-F)** that determine tensioning of the net.

Important

In order to obtain the correct tensioning of the wire support, adjust the braking effect so that the **(F)** output roller is more braked than the **(E)** input roller; also, to prevent the wire support from slipping on the drawing rollers, the latter should not be excessively braked.

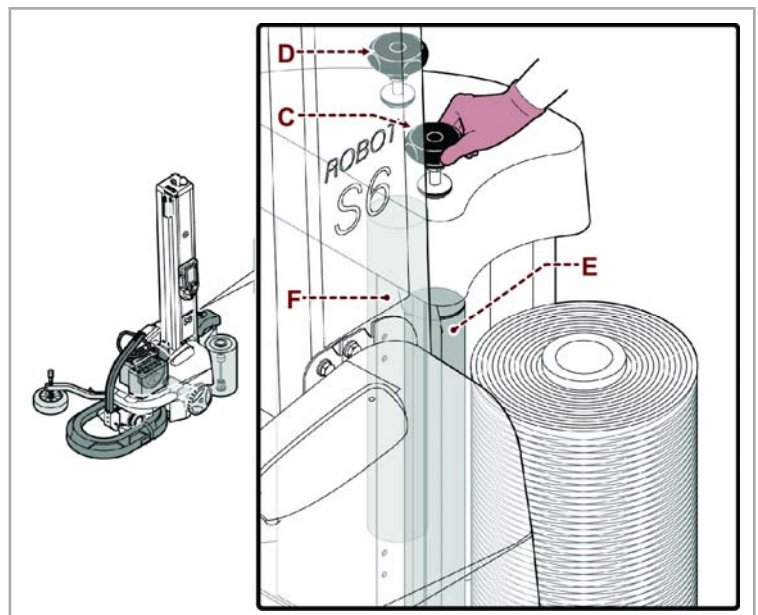

5.4. "PDS" REEL TROLLEYS FOR CHANGING THE DRAWING RATIOS

Proceed as indicated.

1. Stop the machine in safety conditions.
2. Remove transmission cover (A).
3. Loosen the belt (C) through the tensioner (B).
4. Remove the belt from the pulley (D).
5. Loosen the screws (E).
6. Remove the disk (F) including the motor and bearings.

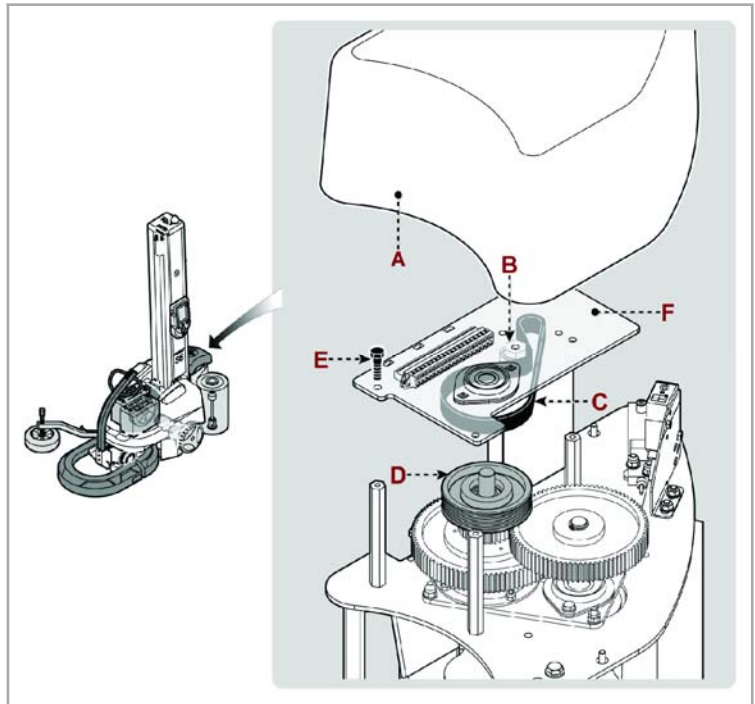

7. Remove the stopping ring (G).
8. Remove the pulley (D).
9. Remove the stopping ring (H).
10. Remove the gear (L).
11. Remove the stopping ring (M).
12. Remove the gear (N).
13. Loosen the screws and remove the small plate (P) from the gear (N).
14. Select the couple of gears (L-N) relating to the pre-stretch percentage involved (see the table).

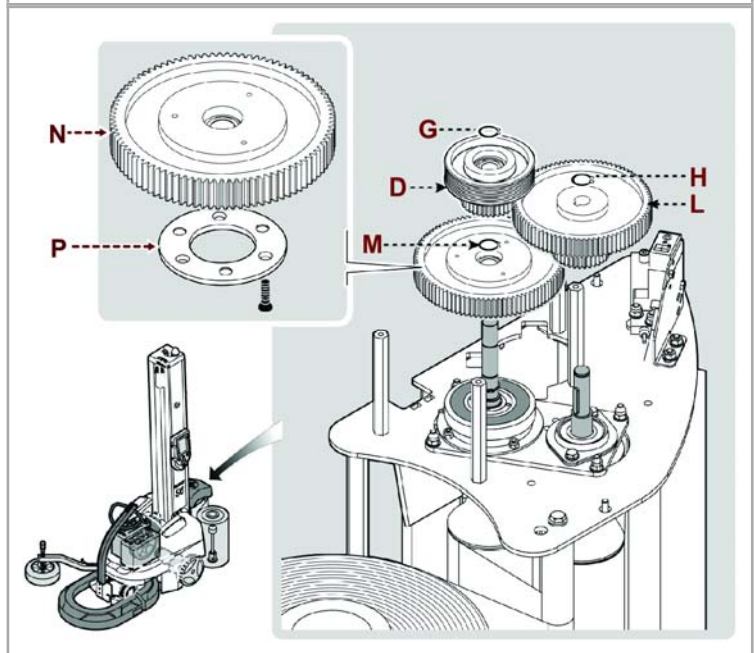

The table lists the pre-stretch values obtainable with the relevant driving ratio.



Important

Set the pre-stretch depending on the resistance and the quality of the coating to obtain low consumption.

Pre-stretch values

Pre-stretch percentage	Gear code (L)	Gear code (N)
150%	(*)	(*)
200%	(*)	(*)
250%	(*)	(*)

300%

(*)

(*)

(*) See spare parts catalogue.

15. Assembly the small plate and correctly fix it to the gear of the new driving ratio.
16. Assembly the gear of the new driving ratio.
17. Position the gear with the side of the small plate coupled to the friction.
18. Assembly the stopping ring.
19. Assembly the gear of the new driving ratio.
20. Assembly the stopping ring.
21. Assembly the pulley.
22. Assembly the stopping ring.



Important

During re-assembly remember to pay attention to the proper insertion of the coupling tabs.

23. Rest the disk on the little columns paying attention to assemble the belt on the pulley.
24. Tighten screws **(E)**.
25. Tension the belt through the tightener.
26. Rotate manually the pre-stretch rollers in both directions to completely adjust the coupling between the belt and the pulleys.
27. Again check the tension of the belt and if needed strain it properly.
28. Re-assemble the casing **(A)** at the end of the operation.

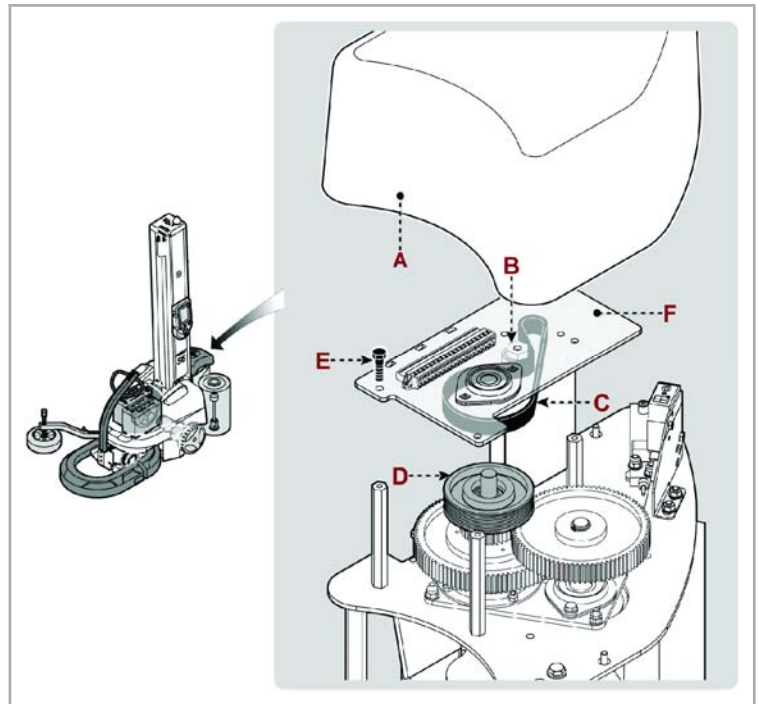

5.5. REEL CARRIAGE LIFTING CHAIN ADJUSTMENT

Proceed as indicated.

1. Lift the spool carriage (with machine operation set to "manual mode") up to "top" end stroke.
2. Switch the machine off.
3. Remove the guard **(A)**.
4. Loosen the nuts **(B)**.

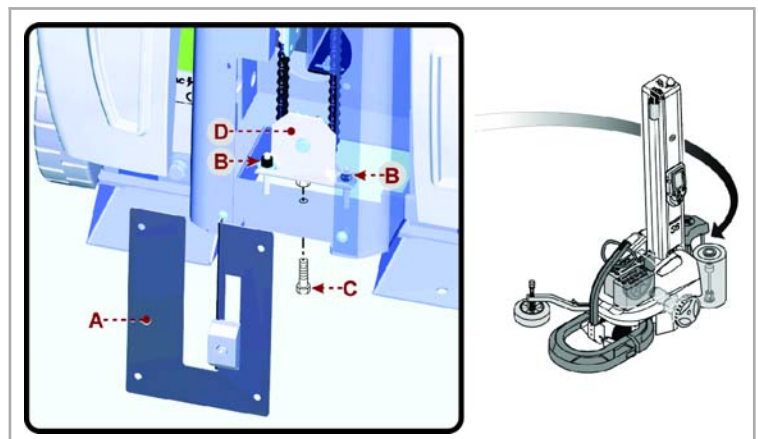

5. Screw on the screw **(C)** "M8x50 UNI 5739" with a tightening torque of **3 Nm** on the chain tensioner **(D)**.
The screw and the torque wrench are not supplied.

6. Re-tighten the nuts up to the surface of the chain tightening pulley.
7. Undo screw (C).
8. Refit the guard (A).

5.6. BRAKE ADJUSTMENT

Proceed as indicated.

1. Lift the machine and rest it on a support.
2. Make sure that the machine is resting correctly, to prevent the risk of crushing during the operation.
3. Remove the guard (A).
4. Loosen the locking nuts (E).
5. Using a thickness gauge (B), insert a spacer of **0,25 mm** near the screw (D).
6. Adjust the distance (C) between the magnet and the flange using the screw (D) until you feel a slight resistance on the thickness gauge.
7. Repeat the intervention near the other screws.
8. Using a thickness gauge, try to insert between the magnet and the flange, at the screws (D), a spacer of **0,3 mm**.
The intervention is considered to be carried out correctly if it is not possible to insert the thickness gauge.
9. Tighten locknuts (E).
10. Refit the guard (A).

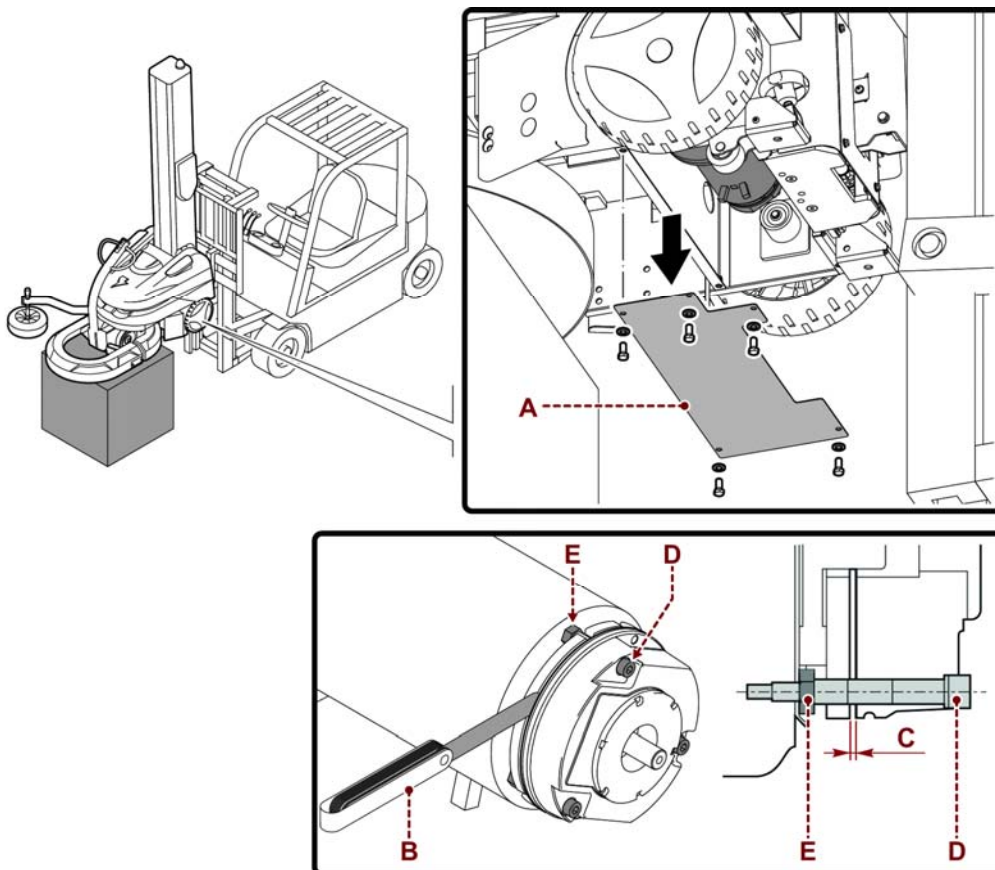

5.7. STEERING ARM RETURN SPEED ADJUSTMENT

Use the screw (A) to adjust the steering arm return speed.

The speed of the steering arm must not be too high to avoid causing personal safety risks.

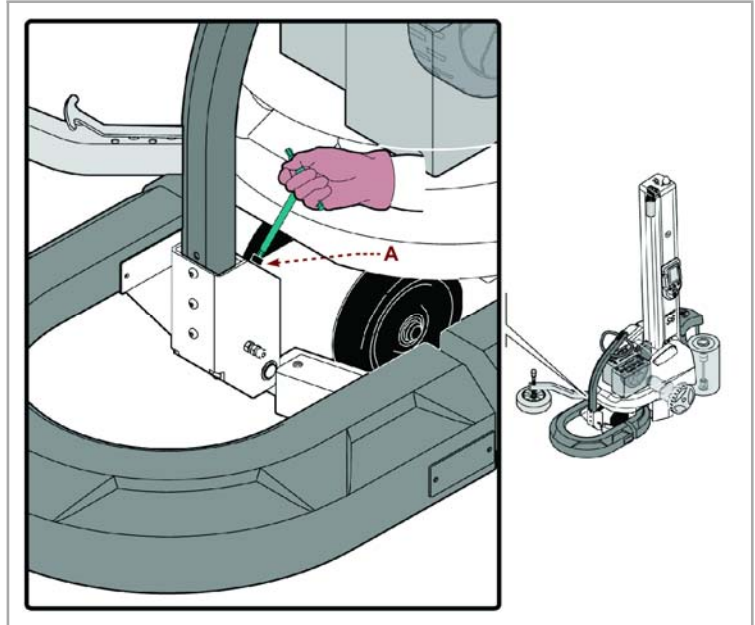

5.8. ADJUSTING THE HEIGHT OF THE SENSING ARM WHEEL

- Pull knob (A), adjust the height of wheel (C) by means of knob (B), then release knob (A) ensuring that the pin correctly inserts in one of the holes.
- To further increase the wheel height, disassemble knob (B), remove the nut of wheel (C) and then reassemble the components on the other side of the lever.

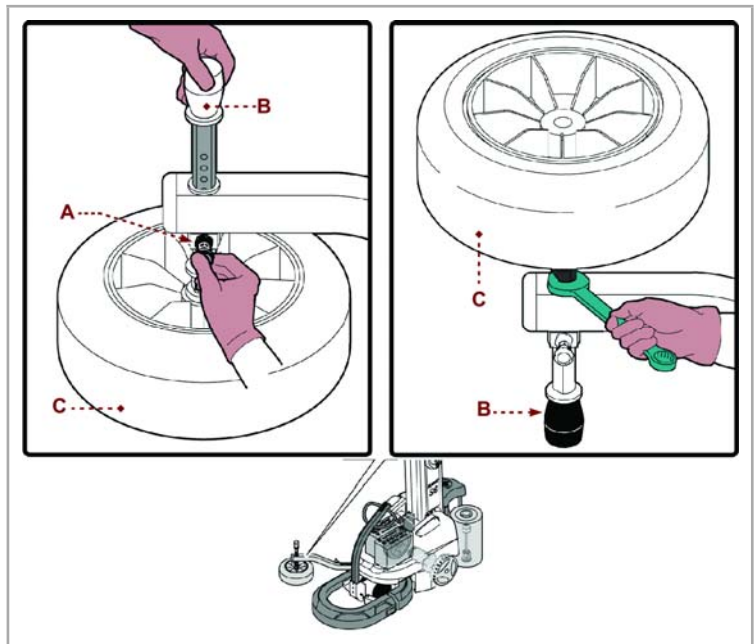

5.9. FEELER THRUST ADJUSTMENT

Proceed as indicated.

5.9.1. STANDARD FEELER

1. Lower the rudder (A).
2. Lift the hood (B).
3. Grip the lever (C).
4. Connect the lever (C) to the tightener (D).
5. Adjust the tightener (D) following its path.
6. Disconnect the lever (C) from the tightener (D).
7. Put back the lever (C).
8. Lower the hood (B).
9. Raise the rudder (A).

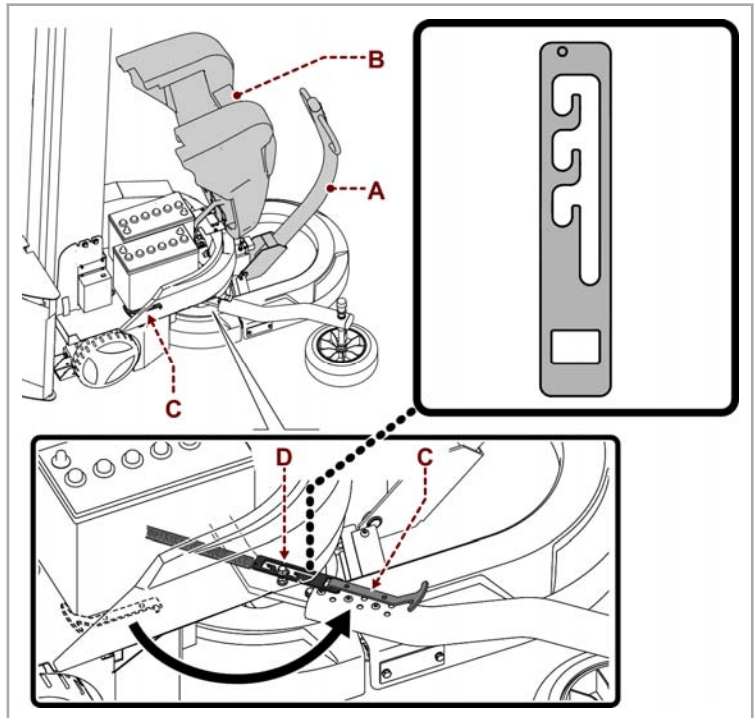

5.9.2. LIGHTENED STEERING WHEEL (OPTIONAL)

1. Open the crank (A).
2. Turn the crank (A) clockwise to increase the thrust of the feeler (C).
3. Turn the crank (A) anti-clockwise to decrease the thrust of the feeler (C).
4. Close the crank (A).
The index (B) provides a visual indication of the thrust of the feeler.

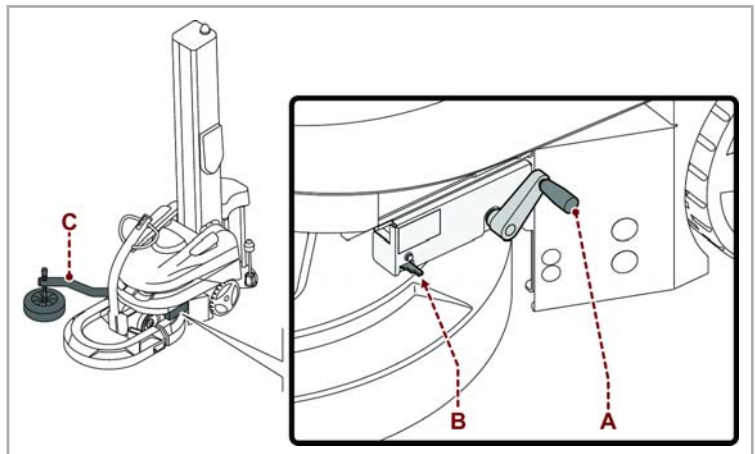

6. ABOUT THE USE

6.1. RECOMMENDATIONS FOR OPERATION AND USE

- Before performing any operation, the operator must make sure that he/she understood the "Instructions for use".
- When using the machine for the first time, the operator must read the manual and identify the controls and simulate some operations, especially the start-up and shutdown.
- Check that all safety devices are installed correctly and in good working order.
- Only implement the uses intended by the manufacturer and do not tamper with any device to obtain performances different from the intended ones.

6.2. CONTROL DESCRIPTION

The illustration shows the main controls of the machine and the list shows their description and function.

A) Emergency stop push-button: it is used to stop with a voluntary action, in case of imminent risk, the organs of the machine that may pose a risk.
For further details consult the paragraph "Description of safety devices".

B) User interface: it is used to set or modify the operating parameters of the machine.
For further details consult the paragraph "Description of the user interface".

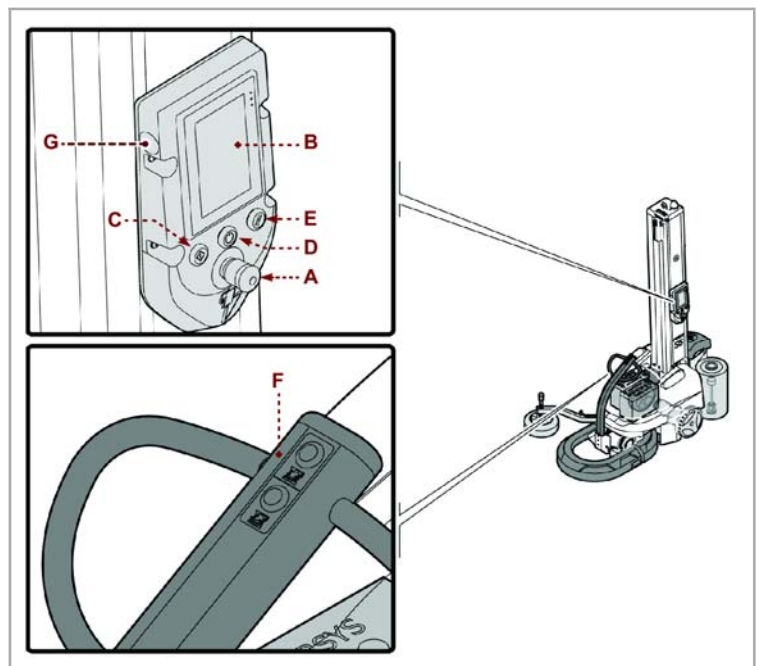

C) "Start cycle" push-button: it is used to start the automatic wrapping cycle.

D) Light button (white light): It is used to power on/off the controls.
When the light indicator turns on, the relevant function is active.

E) "Reset" push-button: it is used to reset the machine before restarting after an emergency stop or to restart it after stopping with power supply cut-off.

F) Buttons (retained activation): They are used to manually move the machine.

G) USB port: it allows exchange of data.

6.3. DESCRIPTION OF THE USER INTERFACE

- The user interface is equipped with an active matrix colour "touch-screen" display.

- By touching each area with your finger the relevant functions are displayed.
- There are two automatic wrapping cycle controls: standard CONTROL and MULTI-LEVEL CONTROL (from the screen "layer home").
- MULTI-LEVEL CONTROL allows you to divide the height of the product in **5** different levels, all of which can be adjusted in thickness, and for each one of them it is possible to regulate the tightness of the film, the drawing (on motorized carriages only), the reinforcements, the rotation speed of the machine and the speed of the carriage.
- Each one of the **5** levels can be set with values depending on the direction of the carriage, which can also be different between ascent and descent.

<i>N.</i>	<i>Name</i>	<i>Function description</i>
1	"Home" screenshot.	The screenshot is displayed at the activation of the Reset control. The page displays the wrapping parameters currently in use and gives access the other pages.
1.1	"Home layers" screenshot.	The screenshot is displayed at the activation of the push-button on the right of the various recipes of the "Recipes" screenshot. The page displays the wrapping parameters currently in use and gives access the other pages.
2	"Manual handling" screenshot.	The screen displays the controls to activate the handling in "manual mode".
3	"Recipes" screenshot.	The screenshot displays the controls to activate the desired recipe.
4	"Wrapping cycle" screenshot.	The screenshot displays the controls to program the wrapping cycle.
5	Screenshot "GENERAL PARAMETERS".	The screenshot displays the controls to program the configuration parameters of the machine.
6	"Production counters (pallets)" screenshot.	The screenshot displays the controls to check the quantity of pallets made (partial and total).
7	"Enabling (H.M.I.)" screenshot.	The screenshot displays the controls to customize the operating mode of the user interface".
8	"Password modification" screenshot.	The screenshot displays the controls to modify the access password to the protected functions.
9	"Password insertion (user login)" screenshot.	This screen displays the controls used to enter the password for the user selected, in order to access the restricted functions.
10	"Service" screenshot.	The screenshot is only reserved to the Manufacturer's Support Service to perform the diagnostics and the basic programming.
11	Wrapping screen with "Special cycles".	This screen shows the controls that activate wrapping with "special cycles".

For details on the listed screenshots, consult the description shown on the specific paragraph.

The illustration shows the logic functional diagram of "navigation" modes.

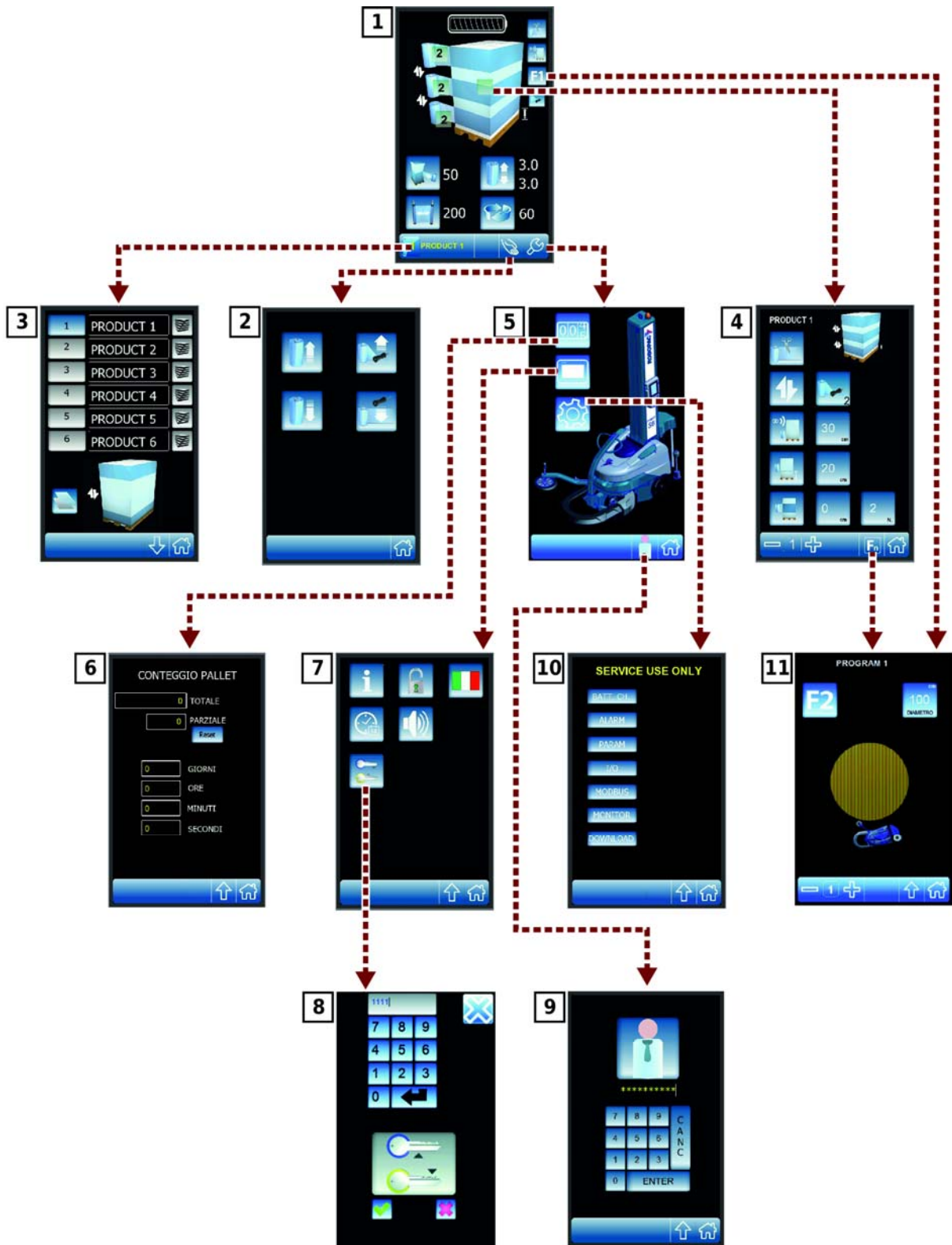

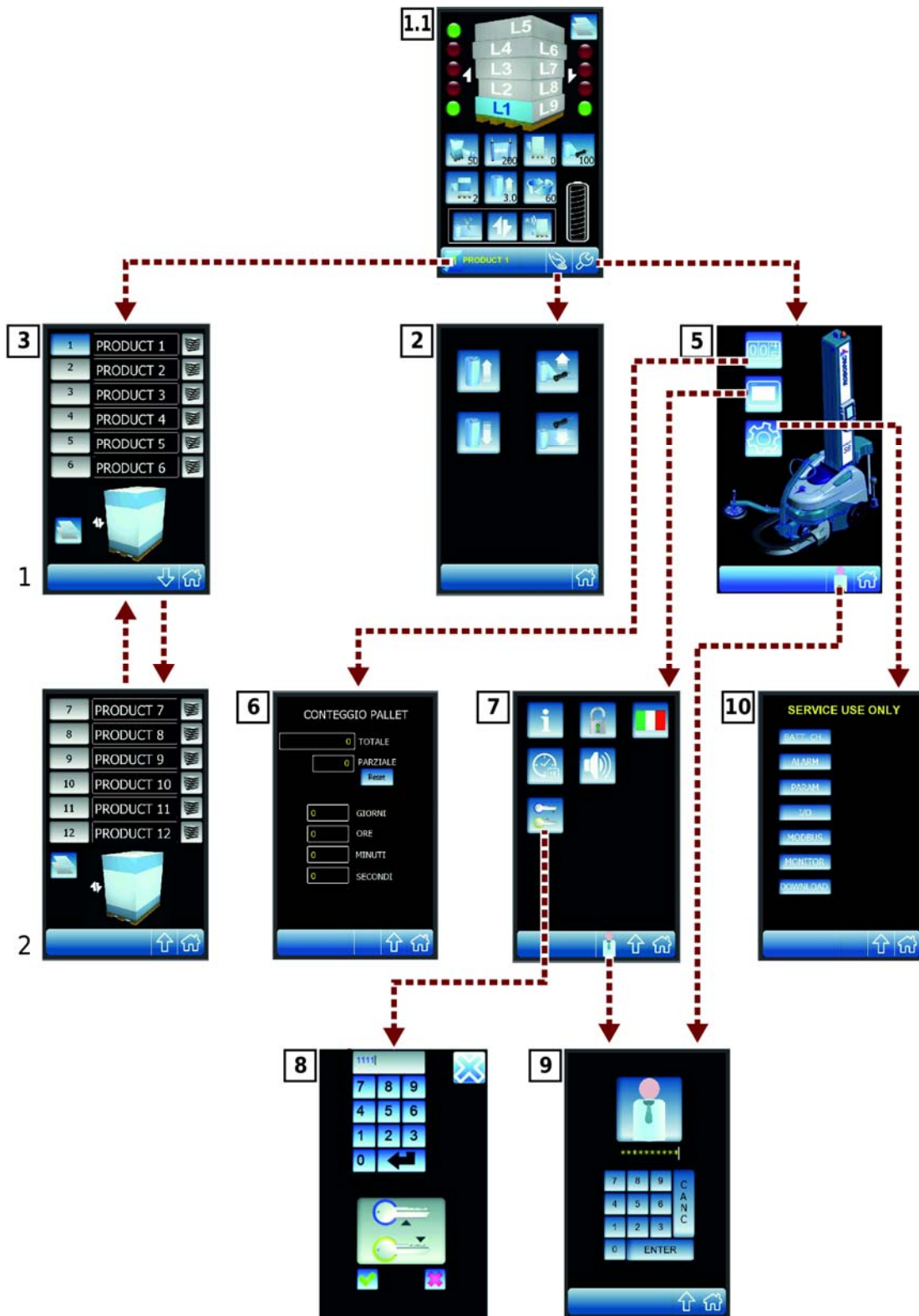

6.3.1. NUMERIC AND ALPHANUMERIC KEYPAD

Some values displayed on the areas of each single screenshot can be properly programmed.
 The keypad is displayed each time you press an area that can be modified or programmed.
 After entering the characters (numeric or alphanumeric), press the button to confirm.
 The area selected shows the value.

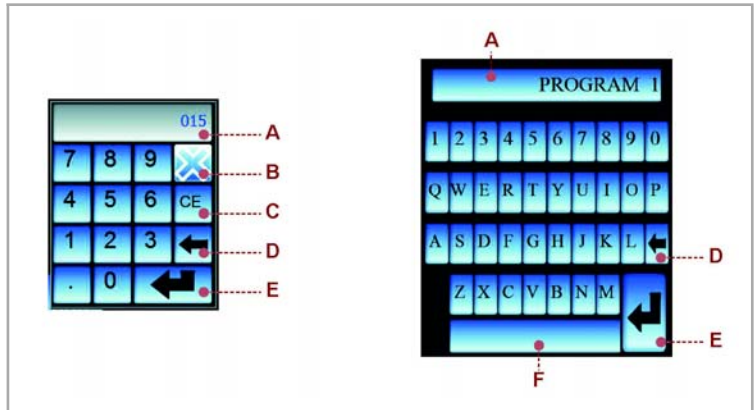

N.	Name	Function description
A	Displaying area.	The area displays the numeric and alphanumeric characters.
B	Push-button.	The activation of the control closes the screenshot and the values entered are not stored.
C	Push-button.	The activation of the control cancels the character selected.
D	Buttons.	The activation of the control cancels a character at a time (starting from the last on the right).
E	Push-button.	The activation of the control stores the value or the text entered.
F	Push-button.	The activation of the control performs the functions of the "spacing bar".

6.3.2. SCHEDULE WINDOW

The window is displayed each time an area that can be changed or programmed is pressed.

A) Area: displays the icon corresponding to the parameter to be programmed. The illustration shows a typical example of window and the table shows the description of icons.

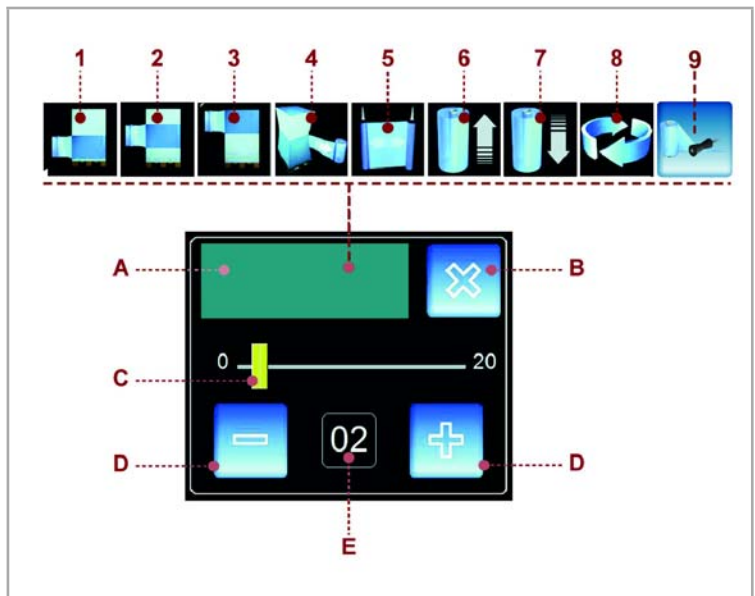

Description of icons

Icon	Function description
1	Lower wrapping
2	Reinforcement wrapping
3	Upper wrapping

4	Coating stretching
5	Coating pre-stretching
6	Trolley lifting speed
7	Trolley lowering speed
8	Machine forward speed
9	Film height adjuster - creasing device

- B)** Push-button: used to close the schedule window.
- C)** Bar: used to increase or decrease (quickly) the value displayed in the area **(E)**.
- D)** Push-buttons: used to increase or decrease (one unit at a time) the value displayed in the area **(E)**.
- E)** Area: displays the value of the parameter programmed.

6.4. "HOME" SCREENSHOT

The page displays the wrapping parameters currently in use and gives access the other pages.

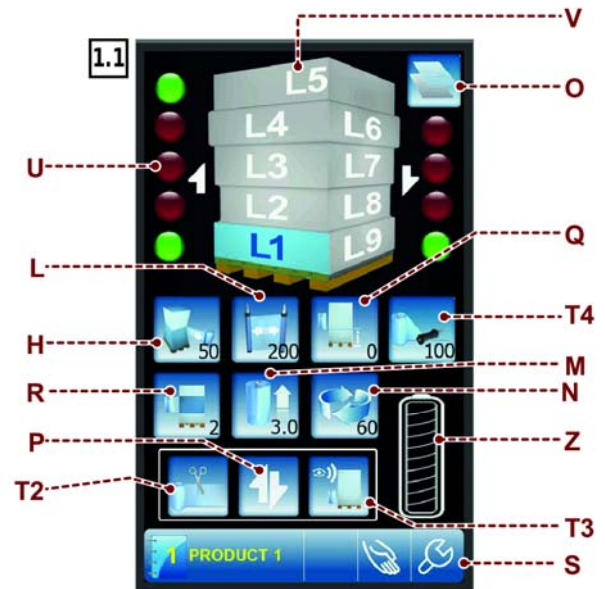
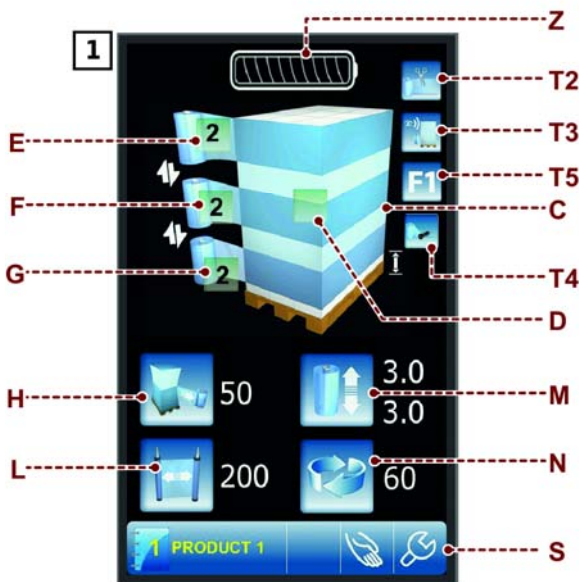

- C)** Area: displays the preview of the pallet wrapping cycle selected.
- D)** Push-button: used to display the "Wrapping cycle" screenshot.
- E)** Push-button: used to program the quantity of wrapping at the upper end of the pallet. The number displayed indicates the value programmed.
- F)** Push-button: used to program the quantity of reinforcement wrapping in the middle area of the pallet. The number displayed indicates the value programmed.
- G)** Push-button: used to program the quantity of wrapping at the base of the pallet. The number displayed indicates the value programmed.
- H)** Push-button: used to program the stretch value of the coating. The number displayed indicates the value programmed.
- L)** Push-button: used to program the pre-stretch value of the coating (only for trolleys "PDS" - "PVS"). The number displayed indicates the value programmed.
- M)** Push-button: used to program the vertical handling speed of the trolley. The number displayed indicates the value programmed.
- N)** Push-button: used to program the wrapping speed of the machine. The number displayed indicates the value programmed.

O) Button: it is used to copy the data of one layer onto another.

Note.

For a description of the keys **P, Q, R, T2, T3, T4** and **T5** see the chapter “wrapping cycle screen”.

P) Wrapping cycle.

Q) Distance from the ground of wrapping start.

R) Programming the reinforcement wrapping.

T2) Cutting (Optional).

T3) Altimeter.

T4) Film height adjuster - creasing device.

T5) **F1** Special cycle.

U) Push-button: used to enable/disable the indicated level.

V) Zone: indicates the number of the level.

Z) Battery charge state indicator: indicates battery charge state.

– Battery ok: The battery condition is signalled by means of coloured bars (green, yellow and red).

– Battery flat: This condition is signalled when the battery level is below **20%**. An alarm message and an acoustic warning are produced.

S) Tool bar.

The tool bar is displayed on all the screens and contains only the keys that can be activated.

The list shows the description of the elements (push-buttons, icons, Etc...) displayed in the area.

- Push-button: used to display the "Recipes" screenshot. The number displayed indicates the activated recipe.
- Area: displays the name of the activated recipe.
- Buttons: They are used to display the screens for programming the set of parameters of the wrapping cycle. The set of parameters displayed is the one in use by the wrapping cycle. For further details, see paragraph ""Wrapping cycle" screen".
- Push-button: used to display the "password insertion" screenshot. For further details consult the paragraph on "password insertion screenshot (user login)".
- Button: it is used to display the “Manual handling” page.
- Button: it is used to display the screenshot “General parameters”.

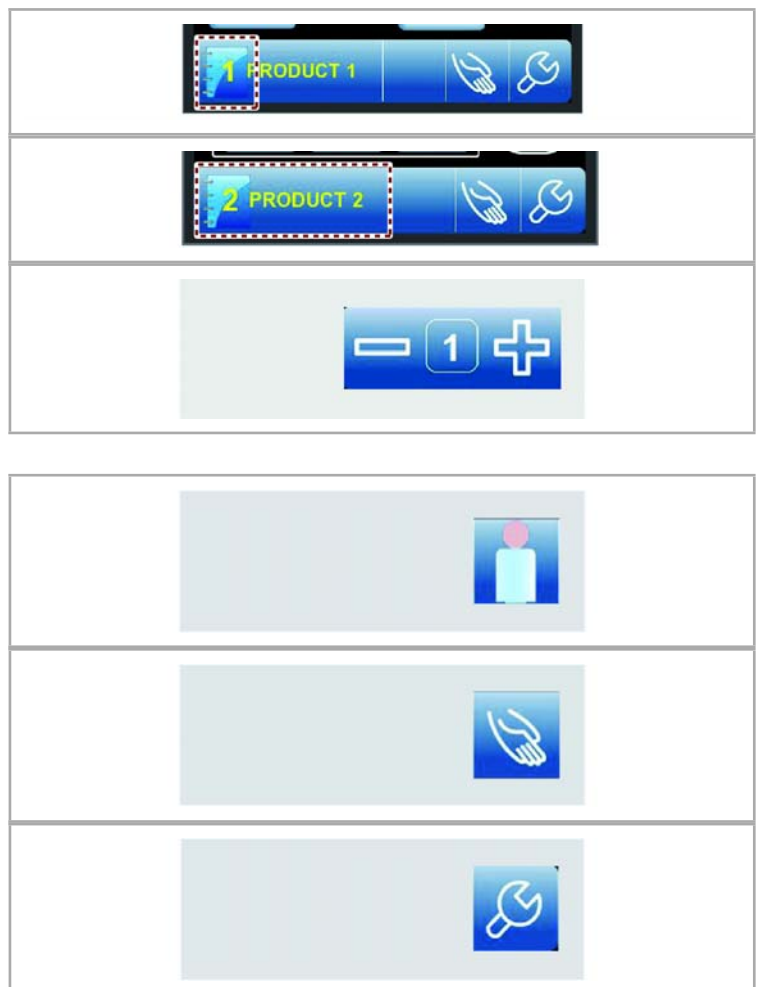

- Push-button: used to display the upper level screenshot.



- Push-button: used to display the "Home" screenshot.



6.5. "MANUAL HANDLING" SCREENSHOT

The controls to activate the vertical handling of the spool carriage in "manual" operation mode are displayed.

- A)** Push-button (JOG): used to activate the lifting of the trolley.
- B)** Push-button (JOG): used to activate the lowering of the trolley.
- C)** Push-button: used to display the "Home" screenshot.
- D)** Push-button (JOG): used to activate the lifting of the creasing device.
- E)** Push-button (JOG): used to activate the lowering of the creasing device.

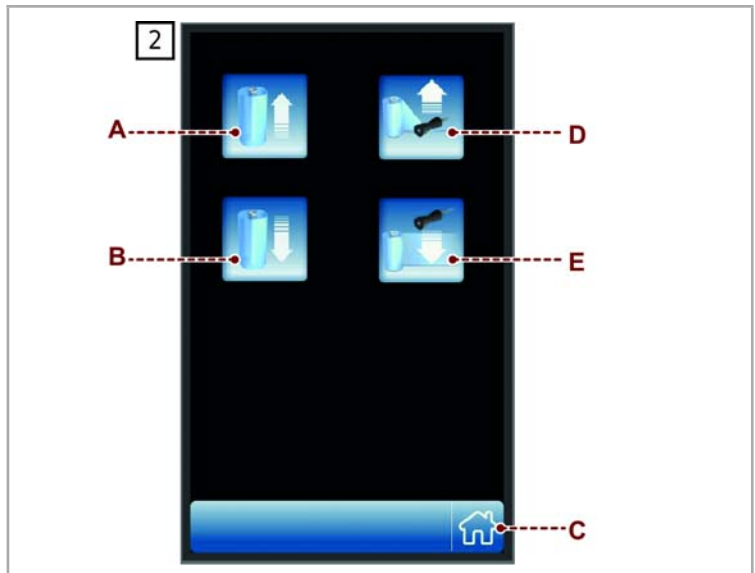

6.6. "RECIPES" SCREENSHOT

The screenshot displays the controls to activate the desired recipe.

- A)** Push-buttons: used to activate the recipe concerned.
Red coloured background: function activated.
- B)** Push-button: used to program the name of the recipe.
- C)** Area: displays the preview of the pallet wrapping cycle selected.
- D)** Push-button: when pressed you access the "recipe copy" screen.
- E)** Button: it is used to enable/disable the "MULTILEVEL CONTROL" for each individual recipe.
- F)** they are used to pass from page **1** to **2** and vice versa, in the screen "RECIPES" **3**.

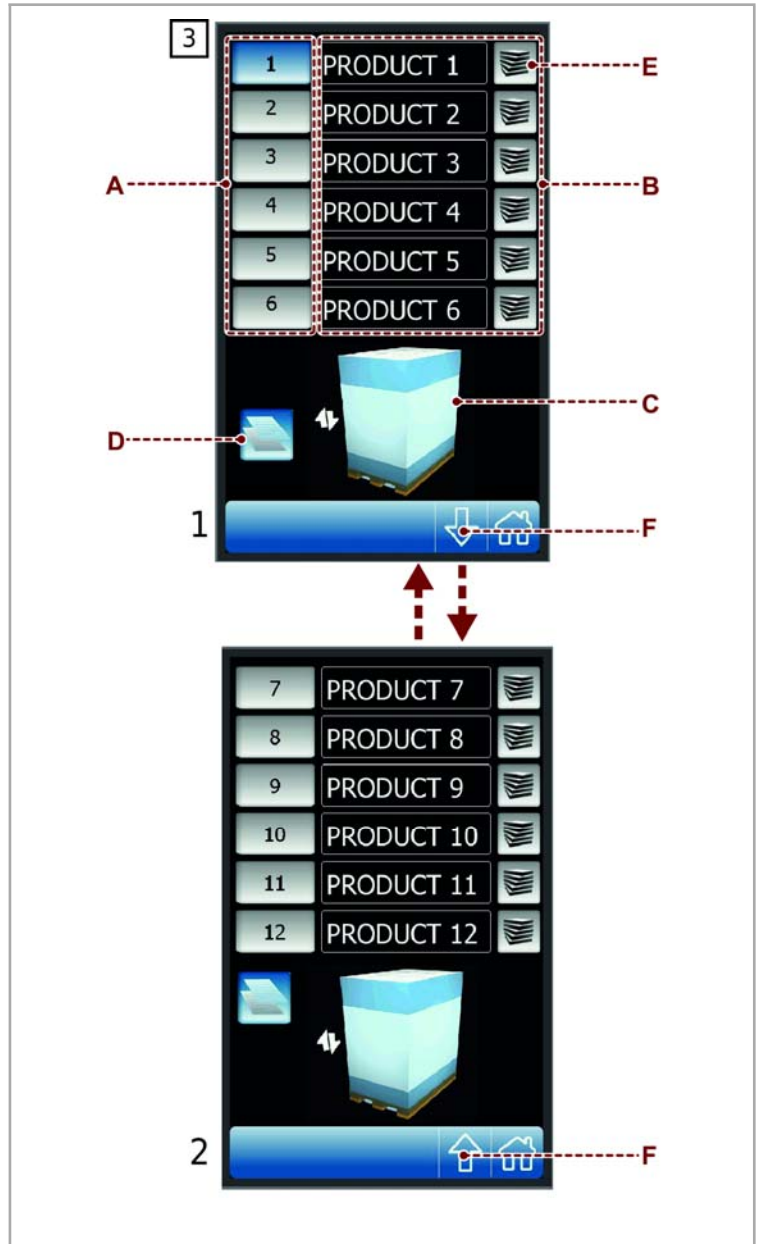

6.6.1. "RECIPE COPY" SCREEN

- A)** Push-button: press +/- to change the starting recipe.
- B)** Push-button: press to confirm the operation (Enter).
- C)** Push-button: used to go back to the "recipes" screen.

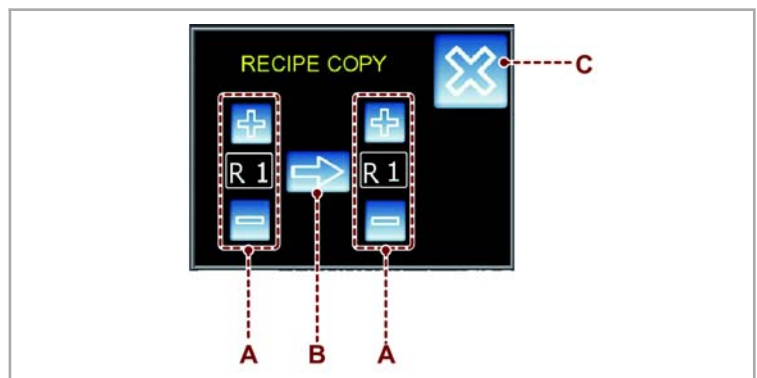

6.6.2. "LEVEL COPY" SCREEN

To copy and move the parameters from one level to another, use the following buttons:

- A) Push-button: press +/- to change the starting level and destination.
- B) Push-button: press to confirm the operation (Enter).
- C) Push-button: used to go back to the "home" screen.

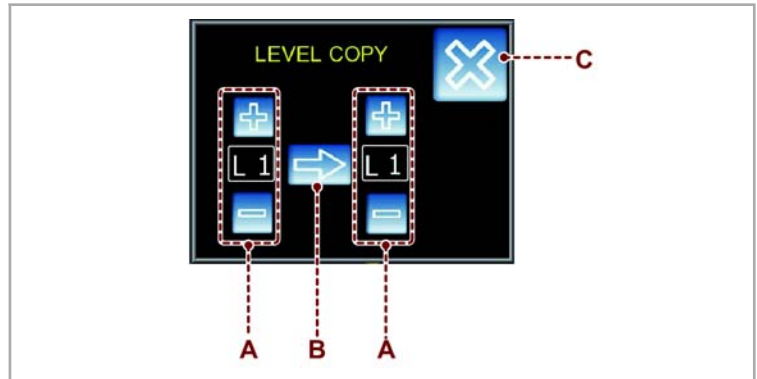

6.6.3. SCREEN "DATA TRANSFER"

To transfer or update the parameters of a certain "work recipe", it is necessary to:

- Insert the portable mass storage in the USB port (A). In the screen bar "RECIPES", the buttons (B) and (C) will appear.
 - By pressing the key (B) it is possible to enable the page "DOWNLOAD RECIPES". By pressing the central key (D), all the "Work recipes" displayed are copied in the mass storage, inserted in the USB port (A).
 - Pressing the key (C), the page "UPLOAD RECIPES" is enabled. By pressing the central key (E), the starting "Recipe", selected in the mass storage, is transferred in the destination "Recipe" of the machine.
- F) Push-button: press +/- to change the starting recipe.
 - G) Button: press +/- to change the destination recipe.
 - E) Push-button: press to confirm the operation (Enter).
 - H) Push-button: used to go back to the "home" screen.
 - R) Push-button: used to go back to the "recipes" screen.

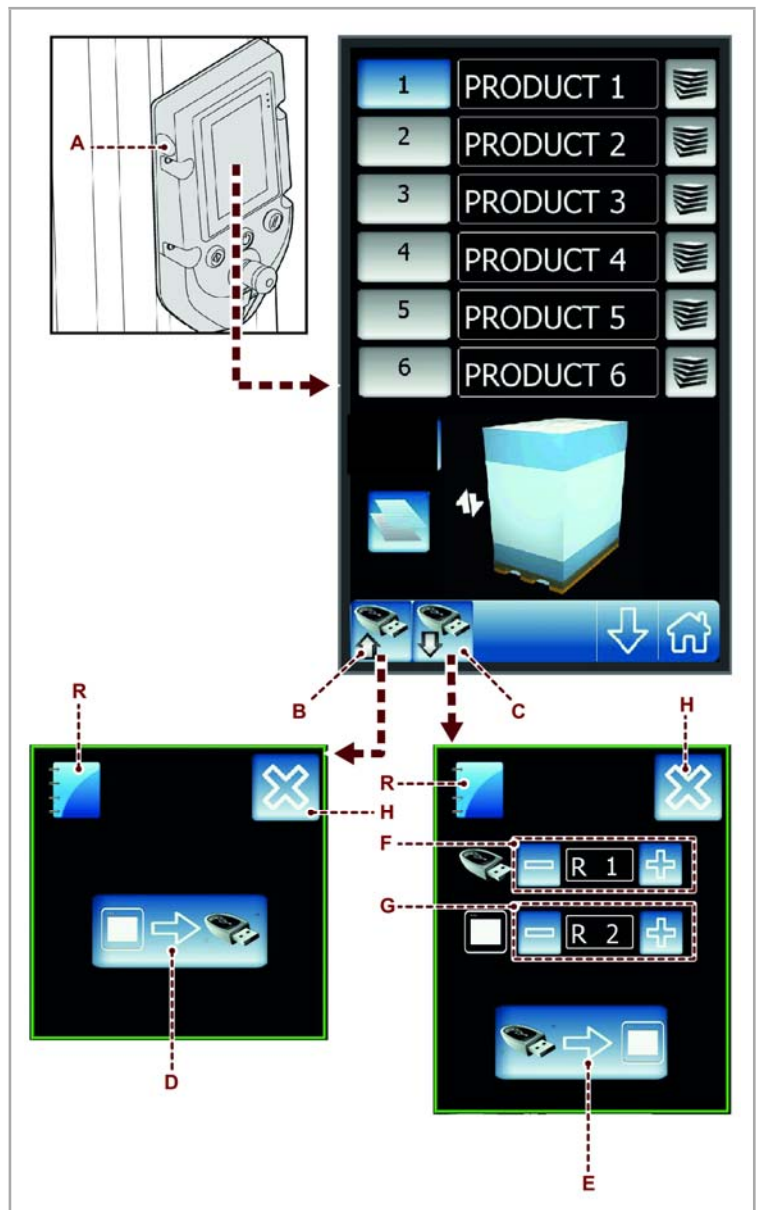

6.7. "WRAPPING CYCLE" SCREENSHOT

The screenshot displays the controls to program the wrapping cycle.

- A)** Area: It displays the name of the set of parameters being programmed.
- B)** Area: displays the preview of the pallet wrapping cycle selected.
- C)** Push-button: used to select the type of wrapping cycle of the pallet.
At each activation, the push-button displays the function enabled with the reference icon:
– Icon **C1**: used to select the "Single wrapping" cycle.
– Icon **C2**: used to select the "Double wrapping" cycle.
– Icon **C3**: used to select the "Double wrapping cycle with sheet feeder".
- D)** Push-button: used to select the stop mode (automatic or programmed) of the spool carriage during lifting.
At each activation, the push-button displays the function enabled with the reference icon.
– Icon **D1**: used to select the automatic stop of the spool carriage (lifting phase) depending on the height of the pallet being wrapped.
– Icon **D2**: used to select the programmed stopping of the spool carriage (lifting phase) depending on the height of the pallet.
- E)** Push-button: used to program the delay time of the stopping point of the spool carriage during lifting (automatic or programmed stopping).
- F)** Push-button: used to enable and disable the programming of the distance from the ground (offset) for wrapping start.
– Blue background: The function is enabled.
– Gray background: The function is disabled.
- G)** Push-button: used to program the distance from the ground (offset) for wrapping start.
The push-button is only visible if the function was enabled through the button **(F)**.
- H)** Push-button: used to enable and disable the programming of reinforcement wrapping.
– Blue background: The function is enabled.
– Gray background: The function is disabled.
- L)** Push-button: used to program the positioning height and the number of reinforcement wrapping.
The push-buttons are only visible if the function was enabled through the button **(H)**.
- M)** Button: it shows the "Wrapping with special cycles" screen.
- N)** Push-button: used to enable/disable the cutting.
- O)** Push-button: used to enable and disable the programming of the cycle with creasing device.
– Blue background: The function is enabled.
– Gray background: The function is disabled.

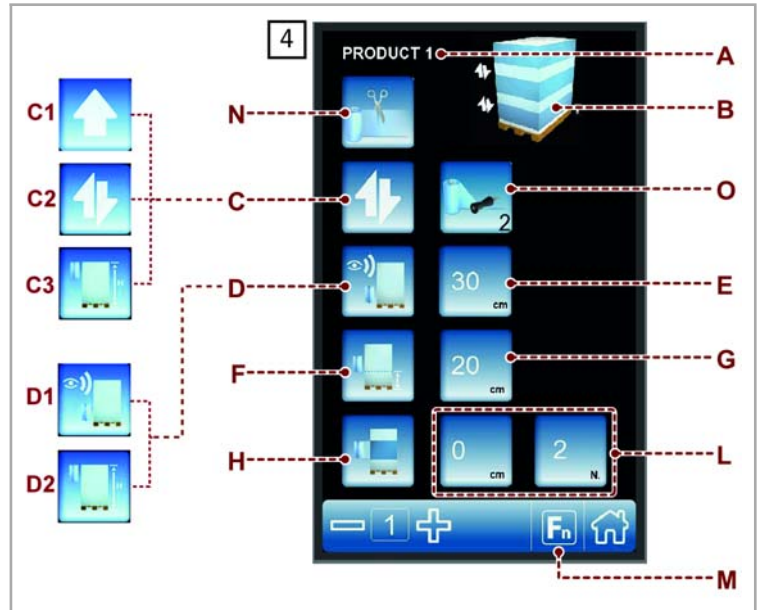

6.8. SCREENSHOT "GENERAL PARAMETERS"

The screenshot is used to program the operating parameters of the machine.

- A) Push-button: used to display the "production counters (pallets)" screenshot.
- B) Push-button: used to display the "enabling (H.M.I.)" screenshot.
- C) Push-button: used to display the "Service" screenshot.
- D) Area: It displays the machine.

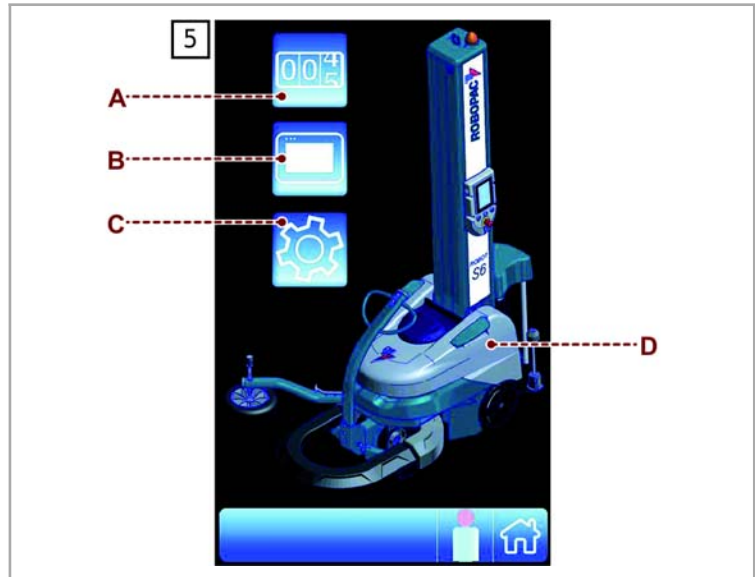

6.9. "PRODUCTION COUNTERS (PALLET)" SCREENSHOT

The screenshot displays the controls to check the quantity of pallets made (partial and total).

- A) Area: displays the counter (total) of wrapping cycles carried out by the machine.
- B) Area: displays the counter (partial) of wrapping cycles carried out by the machine.
- C) Push-button: used to reset the counter (B).
The function is active only if the system is accessed as "machine responsible" (see the "password insertion (user login)" screenshot).
- D) Area: displays the time the machine is used in terms of days, hours, minutes and seconds.

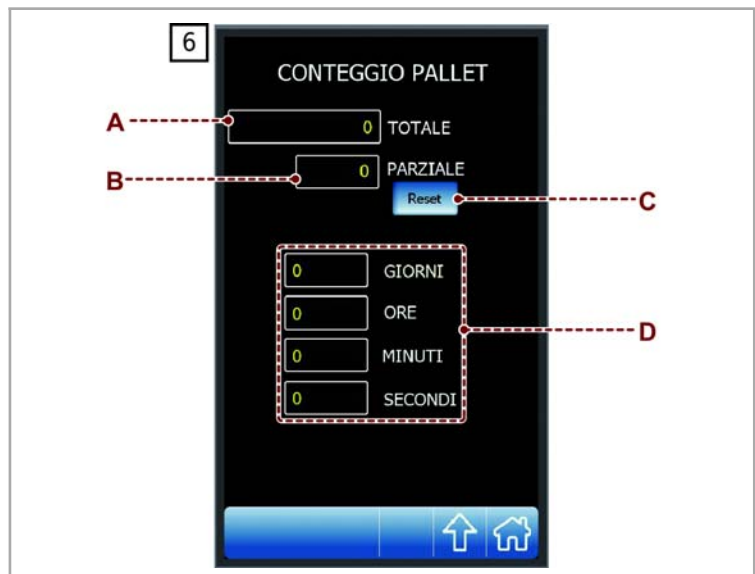

6.10. "H.M.I. SETTINGS" SCREEN

The screenshot displays the controls to customize the operating mode of the user interface".

- A) Push-button: used to display the screenshot showing the software version.
- B) Button: it shows the "Date/ time setting" screen.
- C) Push-button: used to display the "password modification" screenshot.
- D) Push-button: used to enable and disable the programming of recipes. The function is active only if the system is accessed as "machine responsible" (see the "password insertion (user login) screenshot).
- E) Button: used to select the display language.
- F) Push-button: used to enable and disable the acoustic signal of the display.

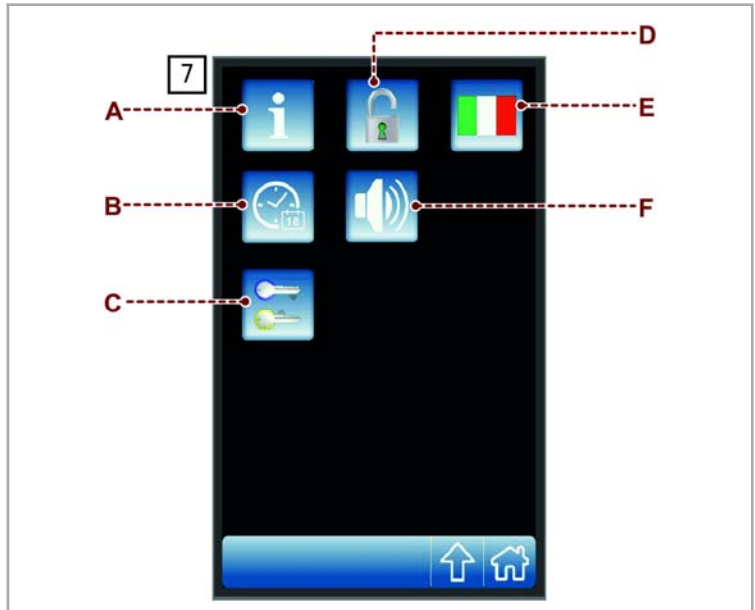

6.11. "PASSWORD MODIFICATION" SCREENSHOT

The screenshot displays the controls to modify the access password to the protected functions.

- A) Push-button: used to display the upper level screenshot.
- B) Area: displays the characters entered.
- C) Numeric keypad.
- D) Push-button: used to confirm the characters entered. The activation of the control is signalled by the animation on the icon (G).
- E) Push-button: used to store the password. The control is enabled only if the animation of the icon (G) is active.
- F) Push-button: used to reset the values entered. The activation of the control deactivates the animation of the icon (G).

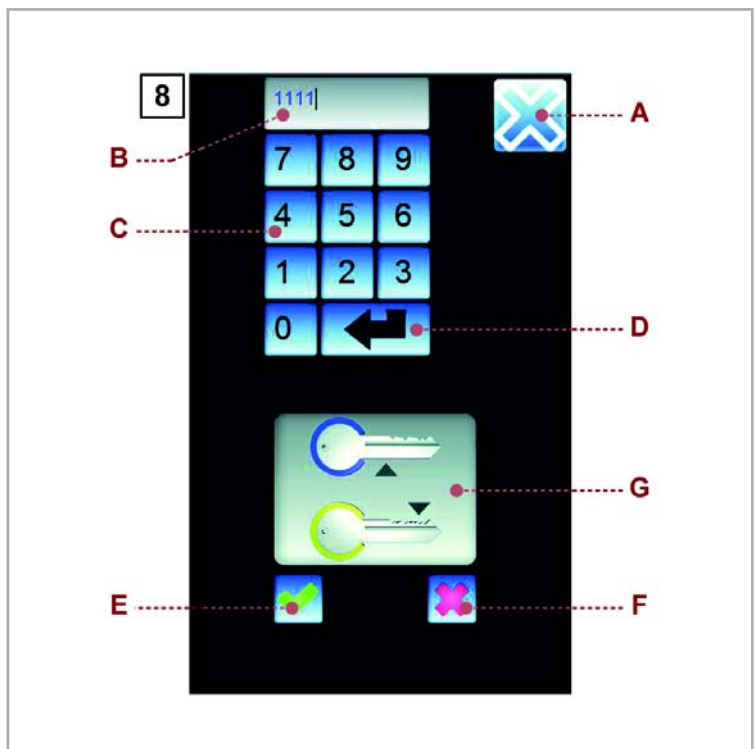

6.12. "PASSWORD INSERTION (USER LOGIN)" SCREENSHOT

This screen displays the controls used to enter the password for the user selected, in order to access the restricted functions.

- A)** Push-button: used to select the type of user concerned.
At each activation, the push-button displays the function enabled with the reference icon.
 - **A1** Icon: used to select the "machine responsible" user.
 - **A2** Icon: used to select the "assistance service" user.
- B)** Area: displays the characters entered.
- C)** Numeric keypad.
- D)** Push-button: used to confirm the password entered (login).
To prevent another type of user from accessing the protected functions, at the end of the operations use one of the following procedures to perform the "user logout".
 - Touch the icon (**A1**) located on the tool bar.
 - Turn off and turn on the machine again.
- E)** Push-button: used to cancel the wrong characters entered.

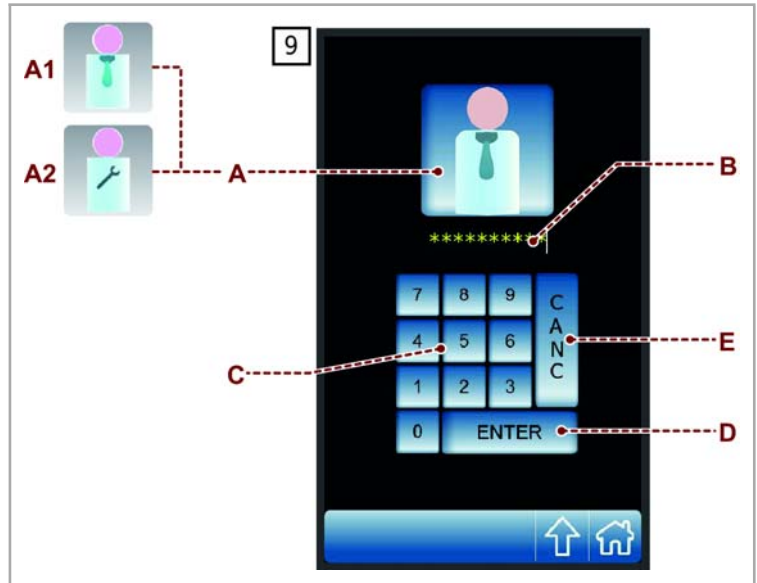

6.13. "SERVICE" SCREENSHOT

The screenshot is only reserved to the Manufacturer's Support Service to perform the diagnostics and the basic programming.

- A)** Button: It is used to access the battery charger screen.
- B)** Button: It is used to access the alarm log screen.
- C)** Button: It is used to access the machine general parameters screen.
- D)** Button: It is used to access the PLC input/output screen.
- E)** Push-button: displays the status of the modbus.
- F)** Push-button: displays the instantaneous pull and drawing.
- G)** Push-button: accesses the screen for updating the software.

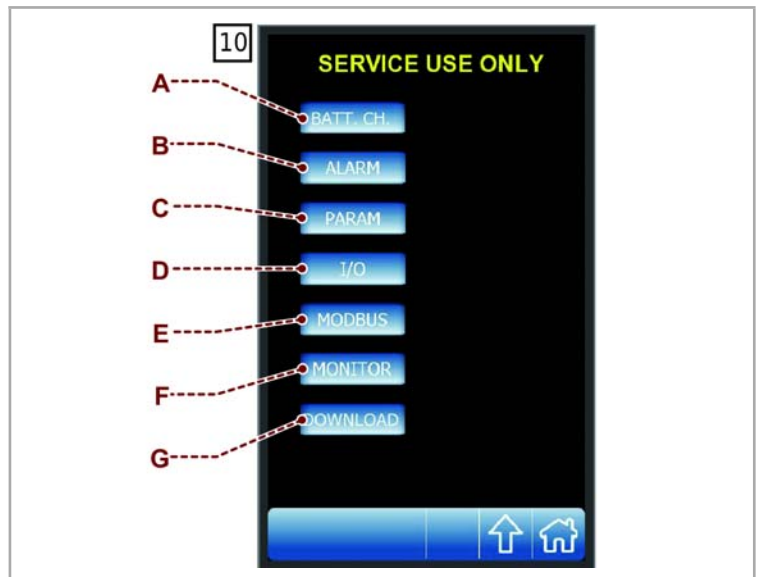

6.14. WRAPPING SCREEN WITH "SPECIAL CYCLES"

This screen shows the controls that activate wrapping with "special cycles".

- A) Area: It displays the name of the set of parameters being programmed.
- B) Button: it selects the type of "special cycle" wrapping.
Press control several times in order to show the desired function.
 - Function "F0": it disables the wrapping with "special cycles".
 - Function F1: it enables the wrapping of large products with "special cycles".
 - Function F2: it enables the wrapping of cylindrical products with "special cycles".
- C) Button: it programmes the wrapping with "special cycles" according to the function selected by means of button (B).
The number displayed indicates the value programmed.
 - With function F1 selected: the control is used to programme the step of the carriage movement at each complete wrapping cycle.
 - With function F2 selected: the control is used to programme the diameter of the product to be wrapped.
- D) Area: displays the preview of the pallet wrapping cycle selected.

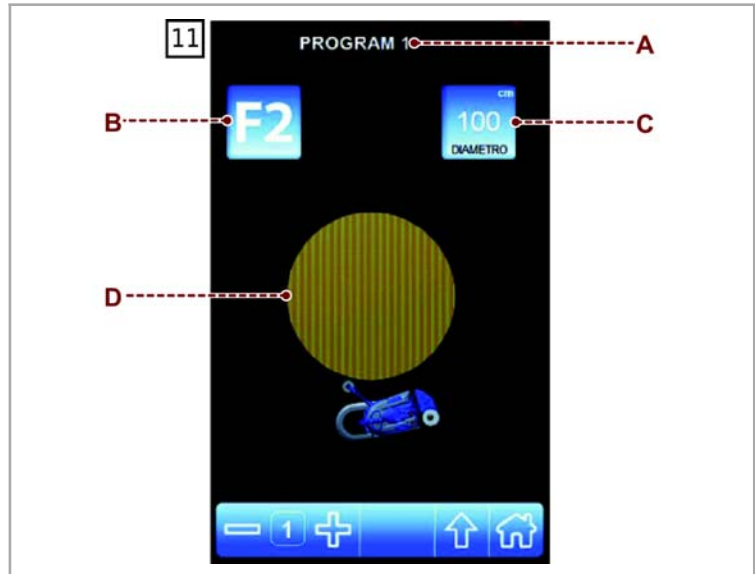

6.15. PROGRAMMING A NEW RECIPE

Proceed as indicated.

1. Display the "Home" 1 screenshot.

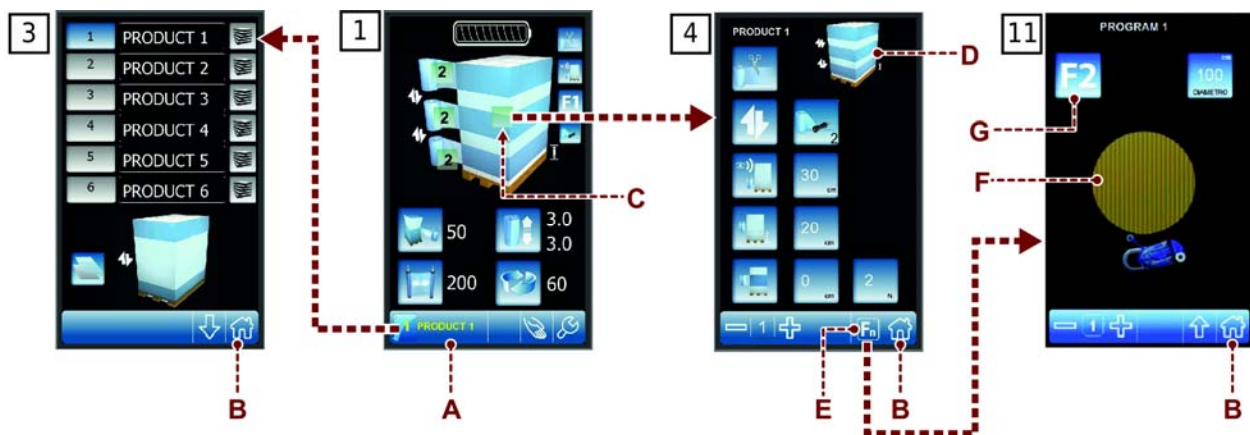

2. Press the button (A) to display the "Recipes" screenshot 3.
3. Select the concerned recipe.
4. Program the name of the recipe.
5. Press the button (B) to display the "Home" 1 screenshot.
6. Press the push-button (C) to display the "wrapping cycle" 4 screenshot.
7. Program the parameters of the recipe.
The area (D) displays the preview of the pallet wrapping cycle.
8. Press button (E) to show the wrapping screen with "Special cycles" 11.

9. Check the type of function shown in button **(G)** in order to programme the desired wrapping.
 - Wrapping without "special cycles".
press button **(G)** until function "**F0**" is shown.
 - Wrapping with "special cycles".
press button **(G)** until function "**F1**" (large products) or "**F2**" (cylindrical products) is shown.
The display in area **(F)** shows the wrapping preview with "special cycles".
10. Press button **(B)** to confirm the programmed recipe.
The "home" **1** screen appears on the display.

6.16. WRAPPING START AND STOP

Proceed as indicated.

1. Press push-button **(D)** to restore electrical power to the controls.
The digital display **(B)** turns on.
2. Press the button **(E)** to reset the machine.
3. Use the buttons **(F)** to approach the machine to the pallet, until the feeler wheel **(G)** is in contact with the pallet.
4. Ensure that the feeler wheel **(G)** is resting against the pallet and not against the product.
Adjust the height of the feeler wheel.
(See "adjusting the height of the feeler wheel").
5. Adhere the film to the pallet.
6. Set the desired wrapping mode.
For further details, see paragraph "Programming a New Set of Parameters".
7. Check that the parameters on the "Home" screen 1 are correct.

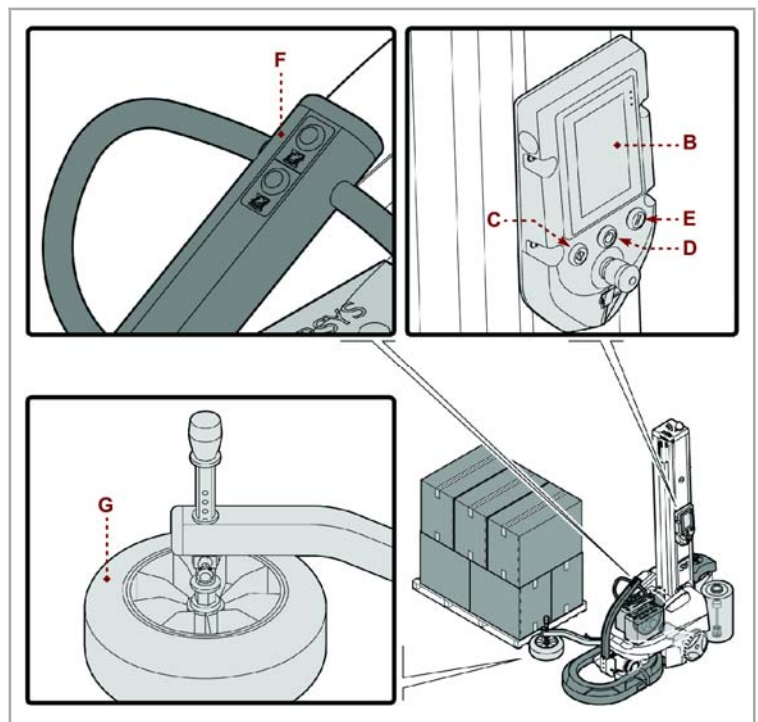

Caution - Warning

Do not over stretch or pre-stretch the film and do not wrap with an excessive number of bindings in order to prevent damaging the packages and products contained inside.

8. Press the "Cycle start" push-button **(C)**.
The machine performs the wrapping process and automatically stops at the end of the cycle.
9. Carry out the cutting of the film (in manual or automatic mode).



Important

If the automatic cut optional unit is provided on the machine, this operation will be performed automatically. Information applicable only to the wrapping mode "Sheet Feeder Cycle".

- When the machine stops at the upper part of the pallet, put the TOP sheet in place (do not cut the film at this stage).
- Press the "Cycle start" push-button **(C)**.
The machine then resumes the wrapping process and stops at the base of the pallet upon completion of the programmed cycle.
At the end of the wrapping phase, the machine may be stopped in "stand-by" mode or turned off.

- When the machine in "stand-by" mode is not used for over **15** minutes, it automatically enters the "energy saving" mode.
To resume operation, touch the machine display.
- If the "power saving" function stays on for more than **60** minutes, the machine automatically turns off.
- Press the button **(D)** to turn off the machine.

6.17. FILM COIL FEEDING

Proceed as indicated.

1. Stop the machine in safety conditions.
2. Insert film reel **(A)** in the proper housing on the reel carriage.
3. Collect some film **(B)** until a thin cord is obtained and make it pass in the conical area **(C)** of the rollers.

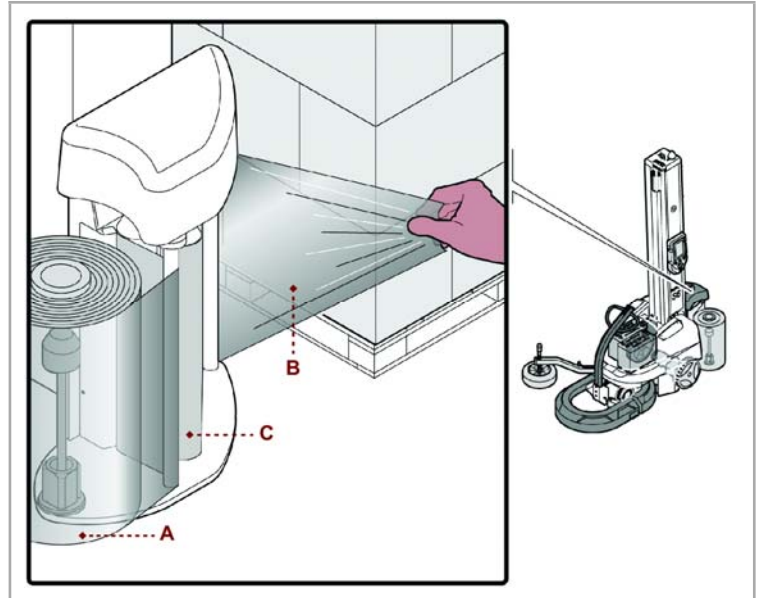

! Important

Unwind the film according to the procedure shown on the label applied on the roll-holder carriage plate.
Reel holding carriage "**FRD** for net".
unwind the film as described in the relevant plate.

4. Pull the cord outwards.
The film will automatically drop on the roller and cover it all along its height.

- On reel carriage type "**FRD**", to insert film or net between the rollers and its unwinding, it is necessary to release the brake by rotating hand wheel **(D-D1-D2)** in position "**0**".

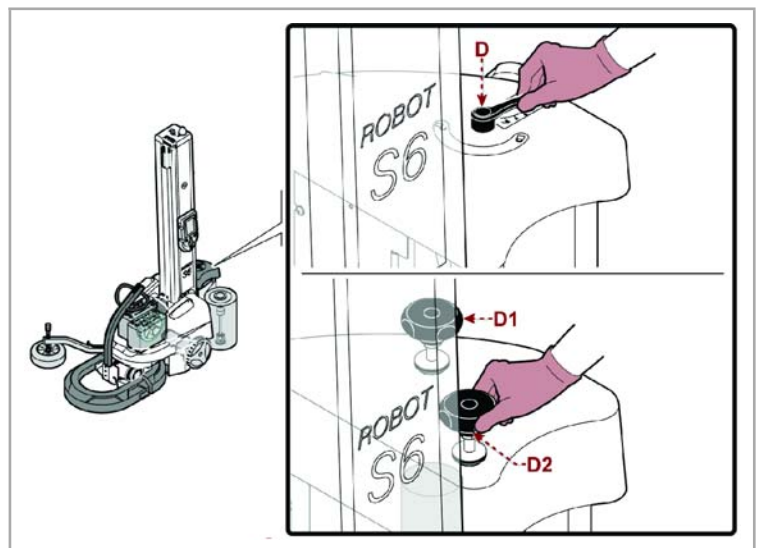

- On reel carriages type "**PVS**", to allow film unwinding, it is necessary to press the roller rotation button (**E**) on the reel carriage.

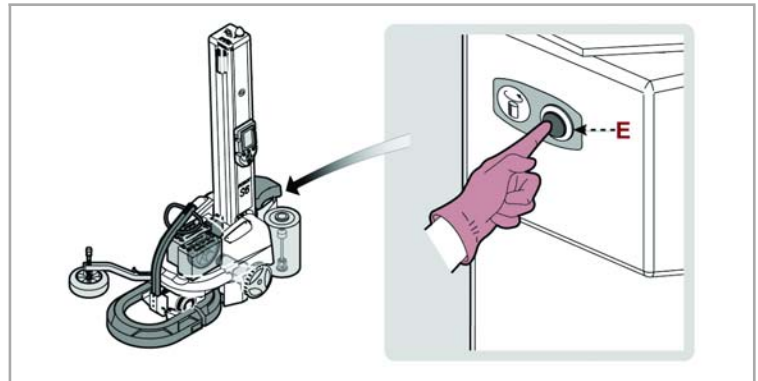

6.18. ADJUSTING CUTTING

The table shows the values of the parameters **P9** and **P10** to be set for the automatic cutting of the coating.

In order to change these parameters, you need to access as the person in charge of the machine. (See "screen "password entry (user login)").

Film thickness	Parameters	
	P9	P10
17µm	80	75
23µm	70	80
35µm	65	80

6.19. BATTERY CHARGING MODE

When the battery level drops below the lower threshold , the machine stops automatically to protect the battery life.

The lower battery threshold is signalled on the battery display by a red bar blinking in the battery icon. The current wrapping cycle is completed and then the display shows the alarm E90-BATTERY LOW (flat battery).

When the alarm is displayed, the machine can **ONLY** be moved to the recharging post.



Danger - Warning

The battery is to be recharged in a place that is wellventilated and distant from the working environment.

Proceed as indicated.

1. Switch the machine off.
2. Lift the battery cover (**A**).

With the additional battery kit, simply replace the basket with empty batteries (see "Battery replacement") with the basket containing the charged batteries.

3. Insert the plug into a socket.



Important

If the operation is performed when the machine is on, it will automatically turn off during the final charging stage.

Any operation should be performed when the machine is off in order to avoid any damage to the components due to the overvoltage that might be generated during charging.

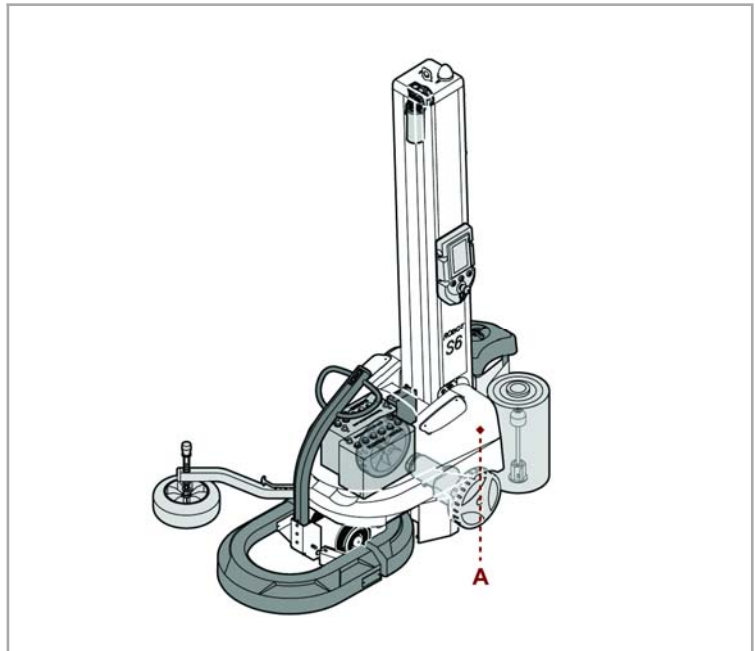

4. Perform the operation and check the charging cycle according to the instructions in the operation manual of the electronic battery charger. For further details, refer to the relevant manual. Upon completion of the recharge, disconnect the plug and close the battery cover.
5. Restart the machine **ONLY** after checking that battery is completely charged (the green LED of battery charger is on and fixed).



Caution - Warning

The battery is subject to a self-discharge process that may compromise its good operations in the long run.

Completely recharge the battery every two months in the event of periods of prolonged disuse.



Important

Wait for the end of the search before disconnecting the battery.

The interruption of the recharging cycle compromises the life of the batteries.

The complete charging time with standard battery charger **S.P.E.** is approximately **13** hours.

The complete charging time with boost battery charger **S.P.E.** is approximately **10** hours.

The complete charging time with battery charger **NORDELETRONICA** is approximately **10** hours.

7. MAINTENANCE INFORMATION

7.1. MAINTENANCE INSTRUCTIONS

- **A good maintenance will allow for a longer working life and constant compliance with the safety requirements.**
- **Before performing any operation, the authorised operator must make sure that he/she understood the "Instructions for use".**
- **Pay attention to the SAFETY WARNINGS, do not use the machine for UNSPECIFIED PURPOSES and assess the possible RESIDUAL RISKS.**
- **Carry out the interventions with all the safety devices enabled and wear the DPI provided.**
- **Mark the intervention area and prevent access to the devices that, if activated, may cause unexpected hazards and jeopardize the safety level.**
- **DO NOT carry out any intervention that is not described in the manual but contact an Assistance Service authorised by the manufacturer.**
- **DO NOT dump in the environment materials, pollutant liquids and the residues created during the interventions but dispose them according to the standards in force.**

7.2. MAINTENANCE PERIOD TABLE

The table below specifies the routine maintenance intervals to be followed to ensure top performances, a longer working life and constant compliance with the safety requirements.

<i>Frequency</i>	<i>Component</i>	<i>Type of intervention</i>	<i>Procedure</i>	<i>Reference</i>
Every 40 hours or 1000 cycles *	Machine operating areas	Cleaning	Use a cloth or compressed air	-
Every 200 hours or 5000 cycles *	Rubber coated rollers	Cleaning	Use a cloth dampened with alcohol	-
Every 200 hours or 5000 cycles *	Reel carriage	Lubricate	-	See "Lubrication point diagram"
Every 200 hours or 5000 cycles *	Reel carriage	Check chain slack	-	See "Reel carriage lifting chain adjustment"
Every 200 hours or 5000 cycles *	Reduction gears and gearmotors	Check lubricant level ¹	Top up, if necessary	See "Lubrication point diagram"
Every 2000 hours or 10000 cycles *	Reel carriage	Check chain wear	Replace chain, if worn out	Contact the Technical Service authorized by the Manufacturer
Every 2000 hours or 10000 cycles *	Inductive sensors	Check efficiency	Adjust the distance between the stops (2 mm)	-
Every 2000 hours or 10000 cycles *	Safety devices	Check efficiency	Have any faulty device replaced	Contact the Technical Service authorized by the Manufacturer

Every 5000 hours or 50000 cycles *	Reduction gears and gearmotors	Change the lubricant ¹	-	See "Lubrication point diagram"
------------------------------------	--------------------------------	-----------------------------------	---	---------------------------------

¹ Do not top-up and/or replace the lubricant in reduction gears and gearmotors lubricated for life.

* The cycle-based frequency was defined according to the standard cycle.
The cycle considered standard is the following: top film reel **500 mm**, top pallet **1500 mm**, pallet weight equal to **1500 kg**, total wrapping time two revolutions at the top, two revolutions at the peak, rotation speed **80 m/1'**, trolley up and down speed equal to **4 m/1'**.

7.3. LUBRICATION POINT DIAGRAM

The following diagram shows the main components and the frequency of the lubrication interventions.

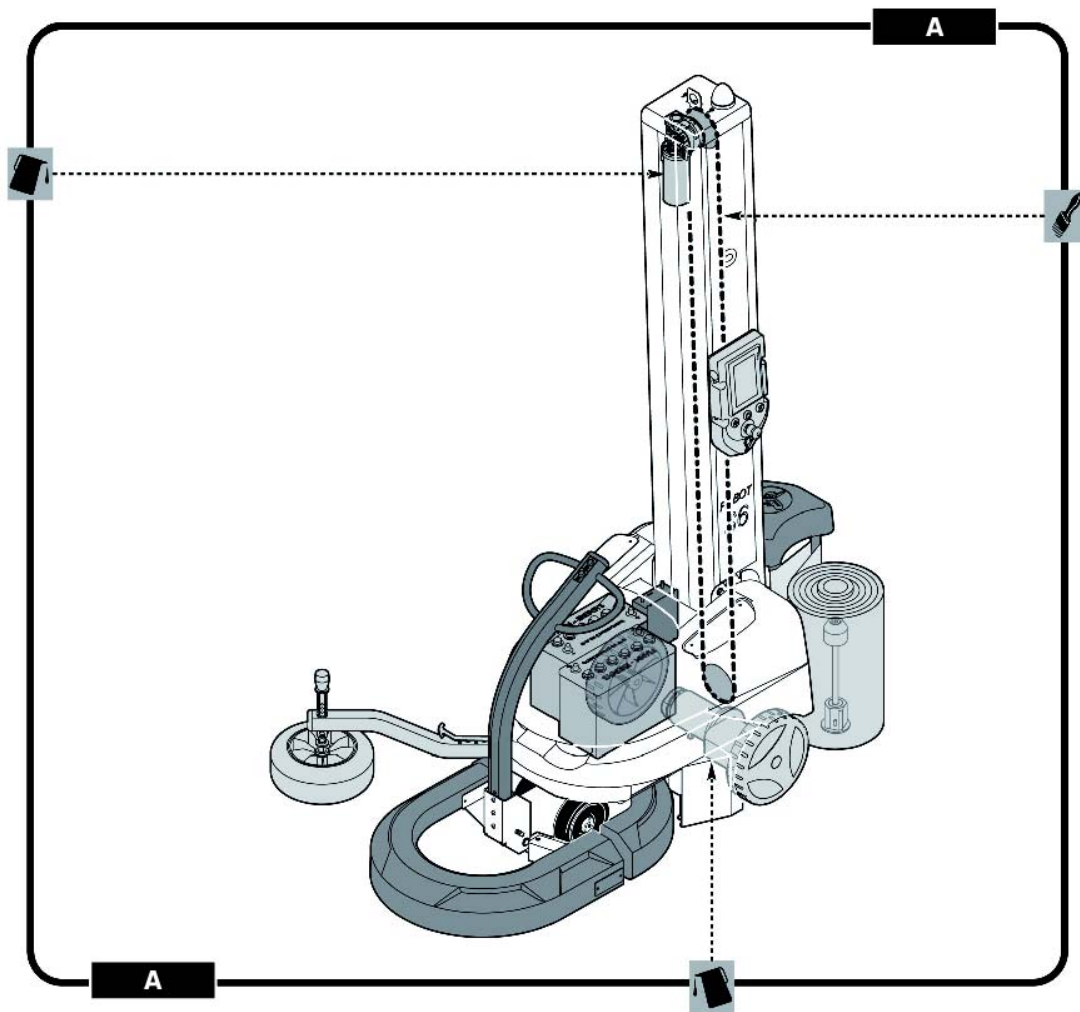

Symbol and Description

A - Every **200** hours or **5000** cycles.

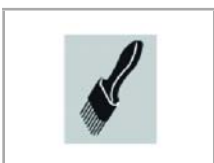

Smear with grease.



Check lubricant level.
Do not top-up and/or replace the lubricant in reduction gears and gearmotors lubricated for life.

Keep to the recommended lubrication frequency to get top machine performances and a longer operating life.

Use lubricants (oils or grease) recommended by the manufacturer or with similar chemical-physical features.

7.4. LUBRICANTS TABLE

The table below specifies the lubricants recommended by the Manufacturer for each component and/or area of the machine.

Use lubricants (oils or grease) recommended by the manufacturer or with similar chemical-physical features.

Lubricant specifications

Type of lubricant	Name	Parts to be lubricated
Mineral oil	23°C / 50°C - 320 CST 40°C MELLANA OIL 320 IP SPARTAN EP 320 ESSO BLASIA 320 AGIP MOBILGEAR 632 MOBIL OMALA EP 320 SHELL ENERGOL GR-XP 320 BP	Gear motor
Mineral oil	32°C / 50°C - 460 CST 40°C MELLANA OIL 460 IP SPARTAN EP 460 ESSO BLASIA 460 AGIP MOBILGEAR 634 MOBIL OMALA EP 460 SHELL ENERGOL GR-XP 460 BP	Worm gear motor
Grease	TELESIA COMPOUND B IP STRUCTOVIS P LIQUID KLUBER TOTALCARTER SYOO TOTAL	Gear and worm gear motor
Synthetic oil	TELESIA OIL IP SYNTHESO D 220 EP KLUBER BLASIA S 220 AGIP	Gear and worm gear motor
Lithium grease	ALVANIA R2 SHELL HL 2 ARAL ENERGREASE LS2 BP BEACON 2 ESSO MOBILIX MOBIL	Bearings with support
Synthetic oil	-5°C / +5°C VG 68 (SAE 20) +5°C / +25°C VG 100 (SAE 30)	Spool carriage chain



Important

Do not mix oils of different makes and specifications.

8. TROUBLESHOOTING

8.1. ALARM MESSAGE LIST AND INFORMATION

In the event of a breakdown during operations the machine stops automatically and alarm messages appear on the display.

The table lists the displayed messages, the type of problem, the cause and possible solutions.



Important

For these operations a precise technical skill or ability is required; therefore, these operations must be exclusively performed by qualified personnel with certified experience acquired in the specific field.

Alarms List

Name	Alarm	Problem	Cause	Remedy
E01	- EMERGENCY STOP	Emergency stop alarm.	The emergency pushbutton is in locked position.	Reset the button and press the Reset button.
E02	- BUMPER	Emergency bumper alarm.	The bumper hit an obstacle in the working area.	Remove the obstacle and press the "Reset" push-button.
E12	- TIMONE BASSO	Only manual operations are possible.	Rudder low.	Raise the rudder. Check the sensor is working and consult the diagram of the electrical system.
E30	- TRACTION DRIVER OVERTEMP - TRACTION DRIVER SHORT CIRCUIT - TRACTION DRIVER UNDERVOLT - TRACTION HEAT SINK OVERTEMP - TRAZ. CURRENT LIMIT	Drive motor alarm.	Drive motor failure.	Check the motor and refer to the wiring diagram.
E31	- CARR. DRIVER OVERTEMP. - CARR. DRIVER SHORT CIRCUIT. - CARR. DRIVER UNDERVOLT. - CARR. HEAT SINK OVERTEMP. - CARR. CURRENT LIMIT.	Carriage motor alarm.	Carriage lift motor failure.	Check the motor and refer to the wiring diagram.

E32	- STRETCH DRIVER OVERTEMP. - STRETCH DRIVER SHORT CIRCUIT. - STRETCH DRIVER UNDERVOLT. - STRETCH HEAT SINK OVERTEMP. - STRETCH CURRENT LIMIT.	Alarm at the film stretching motor.	A failure occurred to the film stretching motor.	Check the motor and refer to the wiring diagram.
E33	- PRESTRETCH DRIVER OVERTEMP. - PRESTRETCH DRIVER SHORT CIRCUIT. - PRESTRETCH DRIVER UNDERVOLT. - PRESTRETCH HEAT SINK OVERTEMP. - PRESTRETCH CURRENT LIMIT.	Alarm at the film pre-stretching motor.	A failure occurred to the film pre-stretching motor.	Check the motor and refer to the wiring diagram.
E35	- TRACTION OVERCURRENT.	Overcurrent alarm at the driving motor.	The motor has been working heavily for an exceedingly long period.	Check the motor operation, ensure the machine is free to move and refer to the relevant electric diagram.
E36	- CARR. OVERCURRENT.	Overcurrent alarm at the carriage motor.	The motor has been working heavily for an exceedingly long period.	Check the motor operation, ensure the carriage is free to move and refer to the relevant electric diagram.
E60	- ALL. BROKEN FILM.	Film end/breakage alarm.	The film has broken or reel is empty.	Insert the film or replace reel.
E61	- ALL. COUNTER CORNER.	Inductive malfunction alarm.	Inductive sensor malfunction.	Check the conditions of the inductive sensor.
E62	- ALL. ENCODER CARR.	Spool carriage lifting encoder alarm.	Spool carriage lifting encoder malfunction.	Check the operation of the motor and/or sensor and refer to the relevant electric diagram.
E65	- ALL. CREASING BLOCKED	creasing device alarm locked.	The motor has been working heavily for an exceedingly long period.	Check the functioning of the motor, assuring that the creasing device is free to move and consult the wiring diagram.

E80	- ALL. BATTERY CHARGER.	Charge battery alarm.	Battery charge failure.	Check the battery charger and refer to the wiring diagram.
E81	- H.M.I. COMUNIC. FAULT.	Communication alarm at the touch screen.	The cable is unplugged or the touch screen is faulty.	Check the operation of the touch screen panel and refer to the relevant electric diagram.
E82	- PRESTRETCH COMUNIC. FAULT.	Faulty serial communication with pre-stretch card alarm.	The cable is unplugged or the board is faulty.	Check the operation of the board and refer to the relevant electric diagram.
E84	- CHECKSUM PARAMETRI CONFIGURAZIONE ERRATO	Setup parameters incorrect alarm.	Machine setup parameter list is corrupted.	To restore default setup parameters, insert into the USB port on the back of the HMI the key supplied with the machine and press the button (A)*. You can also set the parameters manually by pressing the button (B)**.
E85	- CREASING COMUNIC. FAULT.	Creasing device communication alarm.	The cable is unplugged or the board is faulty.	Check the operation of the board and refer to the relevant electric diagram.
E90	- BATTERY LOW.	Battery low alarm.	The battery has run down to the safety level; the machine will stop.	Transport the machine to the nearest charge point using the manual forward/back buttons on the steering arm. see "control description".

* A



** B



9. SPARE PARTS REPLACEMENT INFORMATION

9.1. RECOMMENDATIONS FOR REPLACING PARTS

- Before performing any operation, the authorised operator must make sure that he/she understood the "Instructions for use".
- Carry out the interventions with all the safety devices enabled and wear the DPI provided.
- Delimitate the work area complying with the safety conditions as provided by the standards on workplace safety in order to minimise the risks.
- **DO NOT** carry out any intervention that is not described in the manual but contact an Assistance Service authorised by the manufacturer.
- **DO NOT** dump in the environment materials, pollutant liquids and the residues created during the interventions but dispose them according to the standards in force.
- Replace the components **ONLY** with **ORIGINAL PARE PARTS** or with **SIMILAR** design and functional features.
The use of similar but non-original spare parts may lead to improper repairs, altered performance and economic damage.
- The components and/or safety devices shall be replaces **ONLY** with original spare parts to avoid altering the provided safety level.

9.2. BATTERY REPLACEMENT

Proceed as indicated.

1. Lift the battery cover **(A)**.
2. Remove the connector **(B)** from the socket.
3. Disconnect the terminals **(C-D-E-F)**.



Caution - Warning

First disconnect the negative terminal (-).

4. Remove and replace the batteries **(G)**.
5. Connect again the terminals **(C-D-E-F)**.



Caution - Warning

When connecting the terminals, ensure the polarity is respected.
Cover with grease the positive terminal (+) and connect it first.

6. Plug the connector **(B)** to the socket.
7. Close the battery cover **(A)**.



Important

Do not dispose of used batteries in the environment.
Dispose of the same in compliance with current regulations on the matter.
(See attached literature).

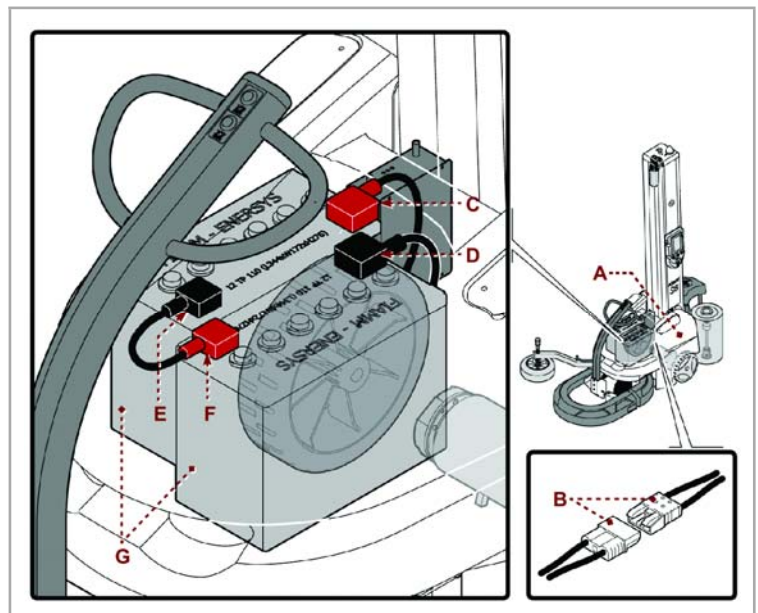

9.3. LIST OF THE RECOMMENDED SPARE PARTS

List of the spare parts of easy wear and of which it would be necessary to have available to avoid long operation stops of the machine.

For ordering, contact your local Dealer and refer to the spare parts catalogue.

- Roller brake pad.
(Only for spool carriages type "**FRD**").
- Carriage clutch.
(Only for spool carriages type "**PDS**").
- Drive belt.
(Only for spool carriages type "**PDS**" - "**PVS**").
- Batteries.
- Front wheels.
- Rear wheels.

9.4. MACHINE DISPOSAL AND SCRAPING

Proceed as indicated.

9.4.1. TAKING THE MACHINERY OUT OF SERVICE

- Disconnect the supplies to the machine (electrical, pneumatic, Etc...) so that it cannot be restarted and position it in a place not easy to access.
- Empty in ad adequate way the systems containing damaging substances and do it in accordance with the current laws in force at workplaces and those regulating environmental protection.

9.4.2. MACHINE SCRAPPING

- Scrapping must be entrusted to authorized centres having the adequate skills and equipment to operate in safety conditions.
- The personnel carrying out the scrapping of the machine must identify any residual energy and implement a "safety plan" to avoid any unexpected hazard.
- The components must be selected depending on the chemical and physical characteristics of the materials and disposed of in a differentiated way, as per current regulations.
- Empty in ad adequate way the systems containing damaging substances and do it in accordance with the current laws in force at workplaces and those regulating environmental protection.

10. ENCLOSED DOCUMENTATION

10.1. WARRANTY CONDITIONS

ROBOPAC S.p.A. pledges, within the limits described herein, to replace or repair, at no charge, the parts that become defective during the **12** (twelve) months following the date indicated on the company's shipping documents.

To utilise the warranty, the user must immediately notify the company that a defect exists, always referring to the machine serial number.

ROBOPAC S.p.A., in its final judgement, will decide whether to replace the defective part or request it to be shipped for tests and/or repairs.

By replacing or repairing the defective part, **ROBOPAC S.p.A.** fully complies with its warranty obligations and will be released from all liabilities and obligations relative to transport, travel and hotel expenses for technicians and installers.

ROBOPAC S.p.A. will never be held responsible for any losses due to lack of production or injuries to persons or damage to things caused by malfunctions or forced suspension in using the machine covered by the warranty.

THE WARRANTY DOES NOT COVER:

- damage caused by transport.
- damage due to incorrect installation.
- improper use of the machine or negligence.
- tampering or repairs by unauthorised personnel.
- lack of maintenance.
- parts subject to normal wear and tear.

For purchased components and parts, **ROBOPAC S.p.A.** offers the user the same warranty conditions that the company obtains from the suppliers of the aforementioned components and/or parts.

ROBOPAC S.p.A. does not guarantee the conformity of machines to current standards in countries that are not part of the European Union.

Concerning any adjustments to standards of the country in which the machine is installed, the user will be fully responsible for the changes made, releasing **ROBOPAC S.p.A.** from any obligation and /or liability relative to any claims that may be submitted by third parties due to non-compliance with the referenced standards.

10.2. BATTERY CHARGER OPERATION MANUAL S.P.E.

Shown below are the directions for use provided directly by the manufacturer of the commercial device, standard or optional, installed on the machine.
The language of such documentation may not correspond to that in which the machine's directions for use are written.

CBHD1 • CBHD2 • HF1-IP • HF2-IP

ELECTRONIC BATTERY CHARGER

OPERATING MANUAL





Attention: read carefully the operating manual before using the battery charger

S.P.E. ELETTRONICA
INDUSTRIALE

	Model	Voltage	Current	Charging Curve				
				IUIa ACD	IUIa GEL	IUIa AGM	IUIo GEL	OTHER
	CBHD1	12V	2A					
	CBHD1	12V	4A					
	CBHD1	12V	5A					
	CBHD1	12V	6A					
	CBHD1	12V	8A					
	CBHD1	12V	9A					
	CBHD1	12V	10A					
	CBHD1	12V	11A					
	CBHD1	24V	2A					
	CBHD1	24V	4A					
	CBHD1	24V	5A					
	CBHD1	24V	6A					
	CBHD1	24V	8A					
	CBHD1	24V	9A					
	CBHD1	24V	10A					
	CBHD1	24V	11A					
	CBHD1	36V	2A					
	CBHD1	36V	6A					
	CBHD2	12V	13A					
	CBHD2	12V	15A					
	CBHD2	12V	18A					
	CBHD2	12V	20A					
	CBHD2	24V	13A					
	CBHD2	24V	15A					
	CBHD2	24V	18A					
	CBHD2	24V	20A					
	CBHD3	12V	15A					
	CBHD3	12V	20A					
	CBHD3	12V	25A					
	CBHD3	24V	15A					
	CBHD3	24V	20A					
	CBHD3	24V	25A					
	HF1-IP	12V	10A					
	HF1-IP	12V	11A					
	HF1-IP	12V	13A					
	HF1-IP	24V	10A					
	HF1-IP	24V	11A					
	HF1-IP	24V	13A					
Other								
	Model	Voltage	Current	Charging Curve				
				IUIa ACD	IUIa GEL	IUIa AGM	IUIo GEL	OTHER

- Storage temperature: from -20°C to +50°C
- Relative humidity: 0 - 80% up to 50°C
- Operating temperature : from 0°C to 40°C

BATTERY CHARGER IDENTIFICATION LABEL

				
Mod. A	Ser. B	Dat. C		
Input: D		Max input current		
Output: E	Fuse: F	Mains H		
Charging curve: G		Batt. I		

A	Model
B	Battery charger serial number
C	Battery charger manufacture date
D	Input voltage
E	Output voltage and current
F	Mains fuse value
G	Charging curve
H	Mains absorption
I	Battery capacity range
L	Product certification stamps

Important safety instruction. Keep these instructions. This manual contains important instructions for the safety of the user and operation of the device.

GENERAL WARNINGS

- 1) Before each use of the battery charger the instructions set out below must be carefully read and abided by.
- 2) The failure to follow these instructions and /or errors in installing or using the battery charger, could lead to endangering the operator and /or damaging the device, voiding the manufacturer's guarantee.
- 3) The battery charger cannot be used as a component in systems which provide life support and/or medical devices, without explicit written authorisation from S.P.E. ELETTRONICA INDUSTRIALE.
- 4) The battery charger must not be used by persons with reduced physical, sensory and mental capabilities or with lack of experience and/or knowledge, unless they are properly supervised and instructed by a person responsible for their safety.

CHILDREN

- 5) The battery charger must not be used by children. The battery charger is not a toy and must not be treated as such.

WHERE TO INSTALL

- 6) Never place the battery charger in the immediate vicinity of the battery in order to prevent gases produced and/or emitted by the actual battery during charging corroding and/or damaging the battery charger. Place the battery charger as far away from the battery as the length of cables permits.
- 7) Do not install the battery charger in a closed space or in such a way as to somehow prevent ventilation. For units equipped with fans, at least 30 mm clearance must be left around the vents. In order to facilitate the heat exchange of the battery charger it must be positioned vertically, exploiting the fixture holes (where provided).
- 8) Do not use the battery charger outdoors.
- 9) Do not expose the battery charger to rain, water splashes or steam.
- 10) Do not install the battery charger in caravans and / or similar vehicles.
- 11) Do not install the battery charger near any heat sources or in areas with high concentrations of dust.
- 12) Do not install the battery charger near any potential sources of flammable material, for example methane gas pipes or fuel depots (petrol, kerosene, ...).
- 13) Do not place and/or fit the battery charger onto surfaces manufactured out of combustible materials, like wooden shelves or walls.

BATTERIES

- 14) Follow the specific safety instructions provided by the battery manufacturer carefully, for example, whether or not to remove cell caps during charging and the recommended charge rates.
- 15) Working in the vicinity of a lead-acid battery is dangerous, as batteries generate explosives gases during charging. Therefore smoking and/or generating open flames and/or sparks must be avoided.
- 16) Never charge a frozen battery.
- 17) Batteries must be charged in specific, well-ventilated areas.
- 18) In order to reduce risk of injury only charge Lead-Acid, GEL or AGM type, Lithium Polymer or Lithium Ion batteries. Do not charge other types of rechargeable or non-rechargeable batteries as they could explode causing damage and/or injury.

FURTHER SPECIFICATIONS FOR LITHIUM BATTERIES

- 19) In order to charge Lithium Polymer and Lithium Ion batteries, a BMS (Battery Management System) must always be used, comprising an active and passive safety system, in compliance with safety regulations in force.
- 20) The possibility of the BMS acting directly on the battery charger operation during cell balancing phases rules out, for any reason whatsoever, that the battery charger is held directly responsible should damage caused to the battery, or even a fire or an explosion, be due to an error in the BMS software.
- 21) The faculty offered by the materials produced by S.P.E. ELETTRONICA INDUSTRIALE to select different levels of voltage for charging, is entrusted to the control and supervision of the end user and S.P.E. ELETTRONICA INDUSTRIALE is not liable for any consequences resulting from the selection of the incorrect level of voltage. If in doubt, the user should ask a qualified professional for clarification.

22) The battery charger tolerance thresholds, as far as levels of over-voltage and overcharging are concerned, are used only for the safeguarding of the systems of the same and have no safety functions for the battery itself, the safety of which depends solely on the BMS, even when the battery charger is connected to the battery, whether the latter is being charged or not.

23) Should the client want to use the battery charger on a specific on-board system and in general in any cases of special usage, it is the client's responsibility to inform S.P.E. ELETTRONICA INDUSTRIALE, so that the latter can draw up any necessary recommendations. In this case, the client must provide S.P.E. ELETTRONICA INDUSTRIALE with all designs, diagrams and descriptive material necessary. S.P.E. ELETTRONICA INDUSTRIALE cannot be held responsible for any damage resulting from the use of the battery charger after opening it and/or modifying it and/or inserting it into other systems.

24) Under no circumstances can S.P.E. ELETTRONICA INDUSTRIALE be held responsible for the malfunctioning of the batteries or the incineration/explosion of these, in so much as the safety of the battery is the task of the BMS and not of the battery charger.

CHECKING CABLES, GRID, EARTHING

25) Do not transport the battery charger by pulling on the cables as they could be damaged.

Use the handles, if provided.

26) Before using the battery charger, check that the sleeving on the mains cable and battery cables is in good condition. Should one of the cables be damaged, have it replaced by a S.P.E. ELETTRONICA INDUSTRIALE qualified technician.

27) Check that the input voltage of the battery charger given on the data plate is in line with the voltage available.

28) Check the compatibility of the mains plug supplied with the battery charger: the use of adaptors is not recommended (in Canada it is against the law).

29) The battery charger must be plugged into a socket fitted with an earth wire. Should the socket not be equipped with an earth connection, do not use the device before having a suitable socket installed by a qualified technician.

30) The power socket to which the battery charger is to be connected must be protected by an electrical device by law (fuse and/or automatic cut-out), capable of absorbing an electrical current equalling the absorption of current stated on the matriculation number of the battery charger, increased by 10%.

31) Do not open the battery charger as there are no parts which can be serviced and/or replaced by the user. Only specialised personnel, authorised by S.P.E. ELETTRONICA INDUSTRIALE may carry out servicing which involves opening the actual device. Electrical/electronic components inside may cause electric shocks even if the device is not plugged in.

CHECKING BATTERY CHARGER OPERATION and CURVE

32) Before charging, make sure that the battery charger is in line with the voltage of the battery, that the charging current suits the capacity of the battery and that the selected charging curve (for lead-acid batteries, or for airtight GEL or AGM type batteries, Lithium Polymer or Lithium Ion batteries) is correct for the type of battery to be charged.

33) We recommend fitting a fuse between battery charger and battery. The fuse must be installed along the connection to the positive terminal of the battery. The rating of the fuse must be proportionate to the nominal output current of the battery charger, the diameter of cable used and the environment in which it is to be installed.

34) We recommend unplugging it from the mains supply before connecting and disconnecting batteries.

35) During normal operation of the battery charger, the external surface may become hot and may remain so for a certain period of time after it has been switched off.

36) The battery charger needs no special maintenance, only regular cleaning procedures, to be carried out according to the type of working environment. Cleaning procedures should only be carried out on the external surface of the battery charger. Before starting any cleaning procedures, the mains supply cable and battery cables must be unplugged. Do NOT use water and/or detergents in general and/or pressure washers of any kind when carrying out cleaning.

LACK OF USE

37) If safe operation of the battery charger can no longer be ensured, stop the device and ensure that it cannot be put back into operation.

38) The specifications set out in this manual are subject to change without any notice. This publication replaces any previously supplied information.

ELECTRONIC BATTERY CHARGER OPERATING MANUAL

TECHNICAL FEATURES OF THE CBHD1 - CBHD2 - CBHD3 - HF1-IP

The innovative characteristics of the CBHD1 - CBHD2 - CBHD3 - HF1-IP range of battery chargers are the following:

1. Advanced technology **High frequency** system.
2. Charging process fully controlled by microprocessor.
3. Universal input voltage: 100-240 Vac
4. Charging process start in the "soft start" mode.
5. Available on request automatic Reset on insertion of a new battery and automatic charge cycle start.
6. Protection against polarity inversions, short-circuits, over-voltages or anomalies by means of an output relay.
7. Battery to battery charger connection without sparks on the output terminals with obvious advantages for the active safety, thanks to the recognition of the battery voltage downstream the normally open output relay.
8. Signaling of possible anomalies by red LED flashing.
9. Insensitive charge parameters in case of $\pm 10\%$ network voltage oscillations.
10. Efficiency > 85%.
11. Output ripple at maximum charge lower than 100mV.
12. Start of the charge cycle even with 2V batteries.

OPERATING PRINCIPLE OF THE CBHD1 - CBHD2 - CBHD3 - HF1-IP

On switching on a new battery charger of the CBHD1 - CBHD2 - CBHD3 - HF1-IP series, the charger will check the battery voltage and decide whether to start the charging process. If the battery is not connected to the battery charger, the yellow LED will flash. If the result of the test is positive after 1 second the charging of the battery can start, with the red LED on. The output relay closes and the current of the first phase rises slowly till the nominal value programmed is reached. If during the battery charge process the user disconnects the actual battery from the battery charger, after a few seconds the battery charger will reset and get ready to start a new charge process (available on request). The progress of the charging process is shown by three LED's: red, yellow and green, as in the whole range of the battery chargers. The green LED shows the end of the charging or the last phase in case of deep charging process; in the former case, the relay is opened to disconnect galvanically the battery from the battery charger.

VISUAL SIGNALS

Please find in the following table a list of the visual signals of the CBHD1 - CBHD2 - CBHD3 - HF1-IP.

SIGNAL (LED)	MEANING
Red LED flashing (twice)	Battery charger set to charge Lead-Acid batteries
Green LED flashing (twice)	Battery charger set to charge GEL and/or AGM batteries
Red LED on	First phase of charge in progress
Yellow LED on	Second phase of charge in progress
Green LED on	End of charge or maintenance phase
ANOMALIES	
Yellow LED flashing	UNSUITABLE BATTERY OR BATTERY NOT CONNECTED OR OUTPUT SHORT CIRCUIT
Red LED flashing	SAFETY TIMER EXCEEDED INTERNAL SHORT CIRCUIT

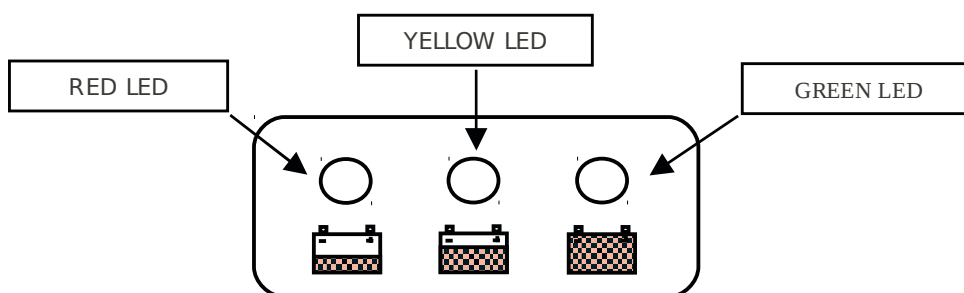

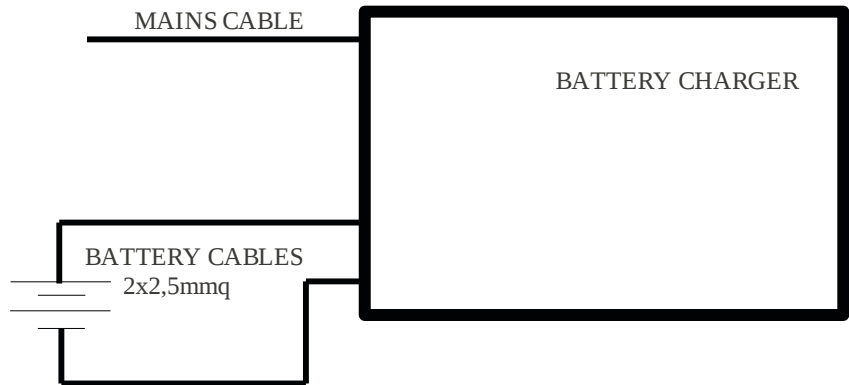

Example diagram of connection between battery charger and battery.

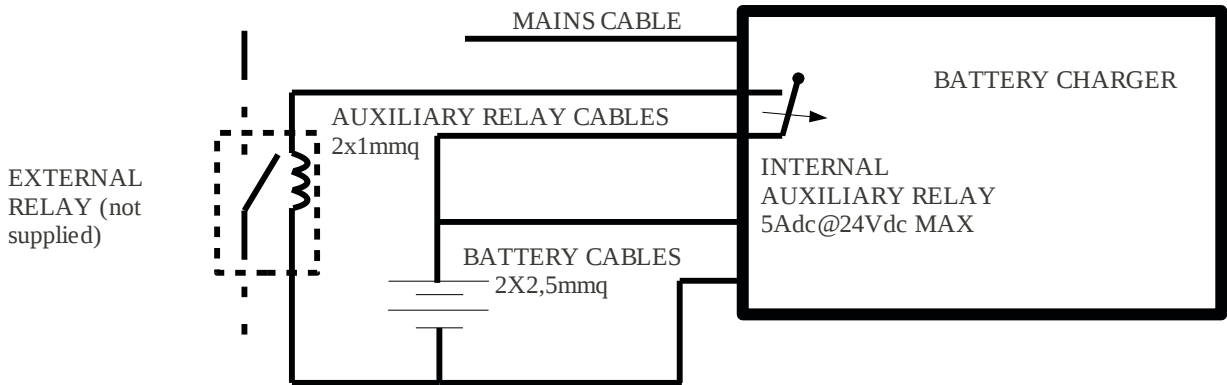

Example diagram of connection with use of battery charger internal auxiliary relay. The auxiliary relay is Normally Off and switches on when the battery charger is turned on. The internal auxiliary relay can be used with maximum voltages of 5Adc to 24Vdc.



CE DECLARATION OF CONFORMITY

According to: **UNI CEI EN ISO/IEC 17050-1:2005**

We

S.P.E. ELETTRONICA INDUSTRIALE di Poletti Sergio
Via di Mezzo Ponente, 383 - 40014 Crevalcore (Bologna) ITALY

Declare under our sole responsibility that the product:

ELECTRONIC AUTOMATIC BATTERY CHARGER MODEL:

to which this declaration applies, complies with the provisions of the Directives of the Council of the European Union on the approximation of the laws of the members states:

Relating to Electromagnetic Compatibility (EMC) Directive 2004/108/EC of the European Parliament and of the council of 15 December 2004 on the approximation of the laws of the member states relating to electromagnetic compatibility and repealing directive 89/336/EEC, conformity is proven by compliance with the following standard:

- ✓ EN 55014-1 (Emission)
- ✓ EN 55014-2+A1+A2 (Immunity - Category II)

Relating to Extra Low Voltage (LVD) Directive 2006/95/EC of the European parliament and of the council of 12 December 2006 on the harmonisation of the laws of member states relating to electrical equipment designed for use within certain voltage limits, conformity is proven by compliance with the following standard:

- ✓ EN 60335-2-29:

“Safety of household and similar electrical appliance - Part 2: Particular requirements for battery chargers”.

- ✓ EN 62233:

“Measurement methods for electromagnetic fields of household appliances and similar apparatus with regard to human exposure”

Crevalcore 01-12-2009

Signature

10.3. BATTERY CHARGER OPERATION MANUAL NORDELETTRONICA

Shown below are the directions for use provided directly by the manufacturer of the commercial device, standard or optional, installed on the machine.
The language of such documentation may not correspond to that in which the machine's directions for use are written.



NORDELETTRONICA

www.nordelettronica.it

BATTERY CHARGER

mod. **NE284**

- I** ISTRUZIONI D'USO
- GB** INSTRUCTIONS MANUAL
- F** INSTRUCTIONS D'EMPLOI
- D** BEDIENUNGSANLEITUNG
- E** INSTRUCCIONES PARA EL USO

95.0001.172 rev. 0

DESCRIPTION:

NE284 is a charger for gel, AGM and lead acid batteries. The batteries must have a nominal voltage of 24V and capacity within the limits given in the technical characteristics.

OPERATION:

The battery charger uses a combination of charge at constant current and constant voltage. This makes possible a significant reduction of the charging time and prevents permanent damage to the battery.

Use the dip switches to choose the charging algorithm according to the type of battery. At switch on, the green led flashes to indicate which algorithm is selected via dip switches (see table page 7).

VISUAL SIGNALS:

- | | | |
|-----------------|---|--------------------------------------|
| - Flashing Red: |  | Verification phase of battery status |
| - Red: |  | First phase of charge |
| - Yellow: |  | Second phase of charge |
| - Green: |  | Battery charged - Maintenance phase |

Alarms

- 1 flashing yellow LED: Battery disconnected or reverse polarity or output short circuit ⁽¹⁾
- 2 flashing yellow LED: Alarm time-out: damaged battery or battery capacity is too high ⁽²⁾
- 3 flashing yellow LED: Faulty battery charger ⁽³⁾
- 4 flashing yellow LED: Overtemperature ⁽³⁾

⁽¹⁾ Verify the battery connection.

⁽²⁾ The alarm is reset disconnecting the main supply. If it persists consult your service.

⁽³⁾ The alarm will be reset itself when the charger cools. Verify the ventilation.

TECHNICAL CHARACTERISTICS:

- Input: 100-240Vac 5A - 2A 50/60Hz
- Output: 24Vdc - 15A
- Battery: 100 ± 160Ah (C5) / 120 ± 180Ah (C20)

PROTECTIONS:

- Input fuse : 10A 250V delayed (internal fuse)
- Reverse polarity
- Short circuit
- Overcurrent
- Overvoltage
- Overtemperature

CONNECTIONS:

- Input: Connector 3-way IEC EN60320 C14
- Output: Red cable AWG12: + **Battery**
Black cable AWG12: - **Battery**
Connector 8-way Mini-FIT JR (MOLEX 39-01-2086); see table page 7

IMPORTANT SAFETY INSTRUCTIONS. SAVE THESE INSTRUCTIONS.

- Failure to install and operate the charger in accordance with these instructions may result in damage to the charger or injury to the operator
- Working in the vicinity of a lead-acid battery is dangerous, batteries generate explosive gases during normal battery operation. For this reason it is of the utmost importance that each time before using the charger, you read and follow the instructions provided exactly.
- To reduce the risk of battery explosion, follow these instructions and those marked on the battery.
- To reduce the risk of injury, charge only lead-acid, AGM or gel batteries (be sure that the selected charging curve is suitable for the type of batteries that have to be charged). Do not attempt to charge any other type of chargeable or non-chargeable battery; these batteries may burst, causing personal injury and damage.
- Lead-acid batteries produce internal explosive gases during charging: prevent flames and sparks and provide adequate ventilation.
- Never charge a frozen battery.
- Study all battery manufacturer's specific precautions such as removing cell caps while charging and recommended rates of charge.
- Never place the charger directly above or below the battery being charged; gases or fluids from the battery will corrode and damage the charger. Locate the charger as far away from the battery as DC cable permit.
- Do not attempt to open the charger. There is risk of electric shock even if the charger is unplugged. No user serviceable components inside.
- Charger surface may be hot while plugged in and for a period of time thereafter.
- Do not expose the charger to the rain. For indoor use only.
- A minimum of 30mm clearance should be provided at each end of the charger. Install the battery charger in a dry and well aired place
- If the cables or output connectors are damaged contact the service center.
- **Disconnect the power supply before connecting or disconnecting the battery connection.**
- This appliance can be used by children aged from 8 years and above and persons with reduced physical, sensory or mental capabilities or lack of experience and knowledge if they have been given supervision or instruction concerning use of the appliance in a safe way and understand the hazards involved. Children shall not play with the appliance. Cleaning and user maintenance shall not be made by children without supervision.
- For the charging of automobile batteries:
 - The battery terminal non connected to the chassis has to be connected first. The other connection is to be made to the chassis, remote from the battery and fuel line. The battery charger is then to be connected to the supply mains.
 - After charging, disconnect the battery charger from supply mains. Then remove the chassis connection and then the battery connection.

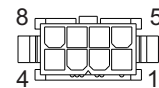
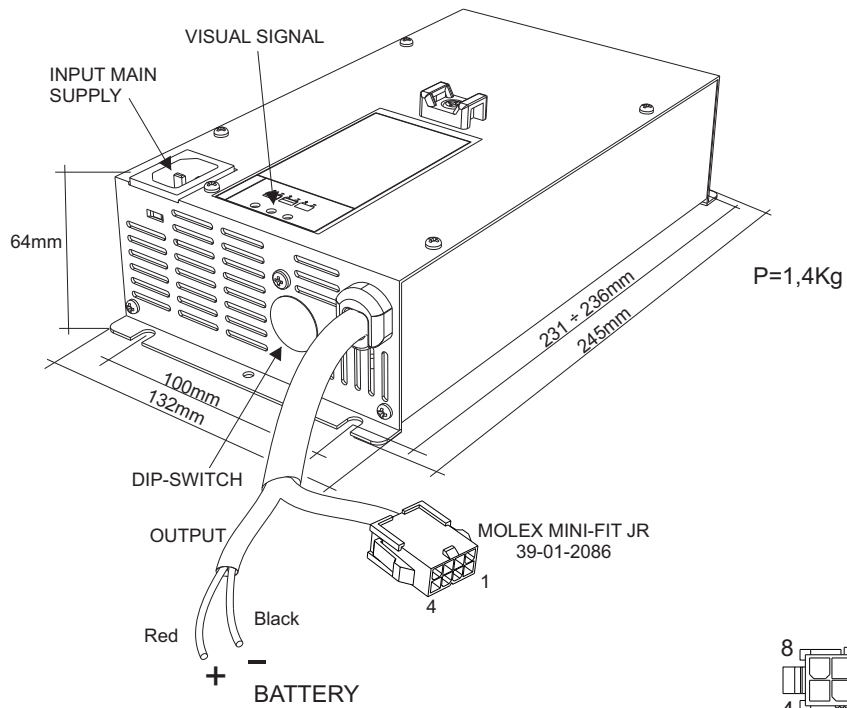

1	no connect
2	no connect
3	COM Relay contact
4	NC Relay contact
5	NO Relay contact
6	RS485-A
7	RS485-B
8	no connect

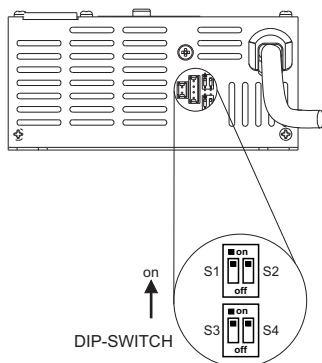

S1	S2	S4	Reference Dip-switch	Algorithm	Status of yellow LED at switch on	Number of flashes of the green LED at switch on
OFF	OFF	OFF	1	IUI0-Pb Flooded	OFF	1
ON	ON	OFF	2	IUI0-Pb Flooded-EnerSys	OFF	2
OFF	ON	OFF	3	IUoU-AGM-GEL	OFF	3
ON	OFF	OFF	4	IUI0-Pb Flooded-Midac	OFF	4
OFF	OFF	ON	5	IUIa-Pb Flooded	ON	1
ON	ON	ON	6	IUIa-Pb Flooded-EnerSys	ON	2
OFF	ON	ON	7	IUIa-AGM-GEL	ON	3
ON	OFF	ON	8	IUIa-Pb Flooded-Midac	ON	4

S3	Output current
ON	13A
OFF	15A



Ref. Certif. No.

DE 2-018758

IEC SYSTEM FOR MUTUAL RECOGNITION OF TEST CERTIFICATES FOR ELECTRICAL EQUIPMENT (IECEE) CB SCHEME

SYSTEME CEI D'ACCEPTATION MUTUELLE DE CERTIFICATS D'ESSAIS DES EQUIPEMENTS ELECTRIQUES (IECEE) METHODE OC

CB TEST CERTIFICATE
CERTIFICAT D'ESSAI OC

Product
Produit

Battery Charger

Name and address of the applicant
Nom et adresse du demandeur

NORDELETRONICA S.r.l.
Viale delle Industrie 6/A
31018 Albina di Gaiarine TV, Italy

Name and address of the manufacturer
Nom et adresse du fabricant

NORDELETRONICA S.r.l.
Viale delle Industrie 6/A
31018 Albina di Gaiarine TV, Italy

Name and address of the factory
Nom et adresse de l'usine

NORDELETRONICA S.r.l.
Viale delle Industrie 6/A
31018 Albina di Gaiarine TV, Italy

Note: When more than one factory, please report on page 2
Note: Lorsque il y a plus d'une usine, veuillez utiliser la 2^{ème} page

Ratings and principal characteristics
Valeurs nominales et caractéristiques principales

Input : AC 100-240V ; 50/60Hz ; 5A-2A ; Class I
Output : DC 24V ; 15A

Trade mark (if any)
Marque de fabrique (si elle existe)

NORDELETRONICA

Model/type Ref.
Ref. de type

NE284

Additional information (if necessary may also be reported on page 2)
Les Information complémentaire (si nécessaire, peuvent être indiqués sur la 2^{ème} page)

A sample of the product was tested and found to be in conformity with
Un échantillon de ce produit a été essayé et a été considéré conforme à la

PUBLICATION **EDITION**
IEC 60335-1:2010+A1
IEC 60335-2-29:2002+A1+A2
for national deviations see test report

As shown in the Test Report Ref. No. which forms part of this Certificate
Comme indiqué dans le Rapport d'essais numéro de référence qui constitue une partie de ce Certificat

28107255 001

This CB Test Certificate is issued by the National Certification Body
Ce Certificat d'essai OC est établi par l'Organisme National de Certification



TÜV Rheinland LGA Products GmbH
Tillystraße 2 · 90431 Nürnberg, Germany
Phone + 49 221 806-1371
Fax + 49 221 806-3935
Mail: cert-validity@de.tuv.com
Web: www.tuv.com

F. Ceriani
F. Ceriani



Date: 30.03.2015

Signature:

Certificate



Certificate no.

CU 72150618 01

License Holder:

NordElettronica S.r.l.
Viale Delle Industrie 6/A
31018 Albina di Gaiarine (TV)
Italy

Manufacturing Plant:

NordElettronica S.r.l.
Viale Delle Industrie 6/A
31018 Albina di Gaiarine (TV)
Italy

Test report no.: USA-CW 31580665 001

Client Reference: Gianni Bressan

Tested to: UL 1564:2006 R3.13
CAN/CSA-C22.2 NO. 60335-1:11
CAN/CSA-E60335-2-29-06 (R2011)

Certified Product: Battery Charger

License Fee - Units

Model Designation: NE284

7

Rated Voltage: AC 100-240V, 50/60Hz
Rated Current: 5A at 100V
2A at 240V

Protection Class: I
Output Ratings DC: 24V/15A

Special Remarks: To be installed according to the licensee's installation instructions.

7

Appendix: 1, 1-9

Licensed Test mark:



Date of Issue

(day/mo/yr)

15/06/2015

10.4. BATTERY DOCUMENTATION ENERSYS

Shown below are the directions for use provided directly by the manufacturer of the commercial device, standard or optional, installed on the machine.
The language of such documentation may not correspond to that in which the machine's directions for use are written.

Operation and maintenance instructions powerbloc dry

ENGLISH

Motive power batteries for small traction
XP series: AGM technology

Sealed gas recombination monoblocs
MFP series: Gel technology

Rating data :

- | | |
|------------------------------|---------------|
| 1. Nominal capacity C_{10} | : see type |
| 2. Nominal voltage | : see type |
| 3. Discharge current | : $C_{10}/5h$ |
| 4. Rated temperature | : 30°C |

Powerbloc dry batteries, XP and MFP series are valve-regulated lead-acid batteries. Unlike conventional batteries with liquid electrolyte these batteries have immobilised electrolyte (gelled sulphuric acid : MFP series or AGM : XP series). Instead of a vent plug, a valve is used to regulate the internal gas pressure, preventing the ingress of oxygen from the air and allowing the escape of excess charging gasses. When operating valve-regulated lead-acid batteries the same safety requirements as for vented batteries apply, to protect against hazards from electric current, from explosion of electrolytic gas and - with some limitations - from the corrosive electrolyte. Battery valves should never be removed. These batteries do not require topping – up with distilled or demineralized water

SAFETY PRECAUTIONS

	<ul style="list-style-type: none"> Pay attention to the operating instructions and keep them close to the battery. Work on batteries must only be carried out by skilled personnel! 		<ul style="list-style-type: none"> Risk of explosion and fire Avoid short circuits: do not use non-insulated tools, do not place or drop metal objects on top of the battery. Remove rings, wristwatches and articles of clothing with metal parts that might come into contact with the battery terminals.
	<ul style="list-style-type: none"> Use protective glasses and wear safety clothing when working on batteries. Adhere to the current accident prevention rules in the country where the battery is used or DIN EN 50272-3, DIN EN 50110-1. 		<ul style="list-style-type: none"> Electrolyte is highly corrosive. In the normal operation of this battery a contact with acid isn't possible. If the cell containers are damaged, the immobilised electrolyte (gelled sulphuric acid or absorbed in the separator for AGM technology) is corrosive like the liquid electrolyte.
	<ul style="list-style-type: none"> Keep children away from batteries! 		<ul style="list-style-type: none"> Batteries and monoblocs are heavy. Ensure secure installation! Use only suitable handling equipment. Lifting hooks must not damage the blocs, connectors or cables. Do not place batteries in direct sunlight without protection. Discharged batteries can freeze. For that reason, always store in a frostfree zone.
	<ul style="list-style-type: none"> No smoking! Do not expose batteries to naked flames, glowing embers or sparks, as it may cause the battery to explode Avoid sparks from cables or electrical apparatus as well as electrostatic discharges. 		<ul style="list-style-type: none"> Dangerous electrical voltage! Avoid contact and short circuits. Caution - metal parts of the battery are always live: do not place tools or other objects on the battery!
	<ul style="list-style-type: none"> Acid splashes into the eyes or on the skin must be washed immediately with an abundance of clean water. After abundant flushing consult a doctor immediately! Clothing contaminated by acid should be washed in water. 		<ul style="list-style-type: none"> Pay attention to the hazards that can be caused by batteries

Ignoring the operating instructions, repair with non-original parts will render the warranty void. All failures, malfunctions or defaults of the battery, the charger or any other accessories, must be notified to our After Sales Service.

1. Commissioning

The XP and MFP series monoblocs are supplied in a charged condition. The battery should be inspected to ensure it is in perfect physical condition. Check

- the battery cleanliness. Before installing, the battery compartment has to be cleaned.
- the battery end cables have a good contact to terminals and the polarity is correct. Otherwise battery, vehicle or charger could be destroyed.

Use special coding systems for maintenance free batteries for the charging plug- and- socket devices to prevent accidental connection to the wrong type of charger. Never directly connect an electrical appliance (for example : warning beacon) to a part of the battery. This could lead to an imbalance of the cells during the recharge, i.e. a loss of capacity, the risk of insufficient discharge time, damage to the cells and this may EFFECT THE WARRANTY OF THE BATTERY.

Charge the battery (see 2.2) before commissioning. Only blocs with the same state of discharge (the same voltage, tolerance like the following table) should be connected together.

Bloc voltage (V)	Max. tolerance from average value - ΔU_{soc}
6	± 0.035
12	± 0.049

After connecting, the terminals must be covered with grease as protection against external corrosion. The specified torque loading for the bolts/screws of the end cables and connectors are:

Flat pole M6	DIN conic post
6 ± 1 Nm	8 ± 1 Nm
Type of monobloc	Specific value
12XP51-12XP73	8 to 10 Nm
6XP180	11 to 13 Nm

2. Operation

DIN EN 50272-3 "Traction batteries for industrial trucks" is the standard which applies.
The nominal operating temperature is 30°C.
The optimum lifetime of the battery depends on the operating conditions (temperature and depth of discharge)
The temperature range of use for the battery is between +15°C and +35 °C. Any use outside of this range must be approved by a Service Technician.
Optimal battery life is obtained with the battery at a temperature of 25-30°C
Higher temperatures shorten the life of the battery (according to IEC 1431 technical report), lower temperatures reduce the available capacity. 45°C is the upper temperature limit and batteries should not be operated above this temperature.
The capacity of the battery changes with temperature and falls considerably under 0 °C.
The optimum lifetime of the battery depends on the operating conditions (moderate temperature and discharges equal to or lower than 80% of the nominal capacity C₀).
The battery obtains its full capacity after about 10 charging and discharging cycles.

2.1. Discharging

The valves on the top of the battery must not be sealed or covered.
Electrical connections (e.g. plugs) must only be made or broken in the open circuit condition.
Discharges over 80% of the rated capacity are deep discharges and are not acceptable. They reduce considerably the life expectancy of the battery. Discharged batteries must be recharged immediately and must not be left in a discharged condition.:

Discharge	Recharge
>40%	Every day
<40%	Every second day

This also applies to partially discharged batteries.
Discharged batteries can freeze.
Limit the discharge to 80% DOD. The presence of a discharge limiter is imperative with an energy cut-off set at 1.90Volts per cell.

2.2. Charging

Powerbloc dry batteries can be recharged with 50 Hz or HF chargers.
If you wish to use an existing charger with WU1a or IU1a profile, you should check that the profile is approved by our Technical Department.
Only connect the battery to the correctly assigned charger, which is suitable for the battery type.

After any changing of cables on the charger, our Technician must visit the site to check the charger setting.
XP and MFP batteries have a low gas emission.
Nevertheless, when charging, correct provision must be made for venting of the charging gases. Battery container lids and the covers of battery compartments must be opened or removed.
With the charger switched off connect up the battery, ensuring that the polarity is correct. (Positive to positive, negative to negative). Now switch on the charger.
When charging the temperature of the battery rises by about 10°C, so charging should only begin if the battery temperature is below 35°C.
The electrolyte temperature of the battery should be at least +15 °C before charging, otherwise a full charge will not be achieved without specific settings of the charger.
Use the correction factor according to DIN VDE 0510-1 (draft) with -0.005 Vpc per °C.

2.3. Equalising Charge

Equalising charges are used to safeguard the life of the battery and to maintain its capacity. Equalising charges are carried out following normal charging. They are necessary after deep discharges and repeated incomplete recharges. For the equalising charges, only the chargers prescribed by the battery manufacturer can be used.

3. Maintenance

The electrolyte is immobilised. The density of the electrolyte can not be measured.
Never remove the safety valves from the monobloc.
In case of accidental damage to the valve, contact our After Sales Service for replacement.

3.1. Daily

- Recharge the battery after every discharge of more than 40% C₀.
- check: the condition of the plugs, cables and that all insulation covers are in place and in good condition.

3.2. Weekly

Visual inspection after recharging for signs of dirt and mechanical damage.

3.3. Quarterly

At the end of the charge, carry out end of charge voltage readings, measure and record :
• the voltage of the battery
• the voltages of each cell
If significant changes from earlier measurements or differences between the monoblocs are found, please contact our Service.
If the discharge time of the battery is not sufficient, check:
• that the required work is compatible with the battery capacity
• the settings of the charger
• the settings of the discharge limiter.

3.4. Annually

Internal dust removal from the charger.
Electrical connections: test all connections (sockets, cables, and contacts).
Monoblocs having terminals with insert :
Check the torque loading of the bolts/screws.:
According to DIN EN 1175-1 when necessary, but at least once a year, the insulation resistance of the truck and of the battery must be checked by an electrical specialist.
The test on the insulation resistance of the battery must be conducted in accordance with DIN EN 1987-1. The average insulation resistance of the battery must not be lower than 50 Ω per Volt nominal voltage (DIN EN 50272-3)
For batteries up to 20 V nominal voltage the minimum value is 1000 Ω.

4. Storage and Transportation

Store the battery in a fully charged condition in a dry, clean and frost free area.
Always disconnect the battery from the electric vehicle before storage.
For easy recharge of the batteries, it is advised not to store without recharge for more than 3 months at 20°C and 2 months at 30°C.
To ensure the battery is always ready for use a choice of charging methods can be made :
• monthly equalising charge according to 2.3.
• float charge with 2.27 V x number of cells

Always recharge before putting the battery into service.
The storage time should be taken into account when considering the life of the battery.

Back to the manufacturer!
Batteries with this sign must be recycled.
Batteries which are not returned for the recycling process must be disposed of as hazardous waste!



Normes de référence:
EN 50272-3 - CONDITIONS DE SÉCURITÉ REQUISES POUR LES BATTERIES D'ACCUMULATEURS ET LEUR INSTALLATION.

Données de la batterie

1. Tension nominale (V): voir étiquette 1,70 Vpc
2. Capacité nominale C₂₀: voir étiquette 30°C
3. Courant nominal de décharge: C_{2/5}

LES BATTERIES ET LES ÉLÉMENTS SONT LOURDS. RESPECTER LES RECOMMANDATIONS DE SÉCURITÉ ET UTILISER DES ÉQUIPEMENTS ADEQUATS.

Durant les opérations sur les batteries, porter des lunettes et des vêtements de protection.

Ne pas fumer. Ne pas utiliser de flammes nues, éviter les courts-circuits, toute source d'étincelles à proximité de la batterie et dans la zone de recharge.

ATTENTION! Les parties métalliques de la batterie sont toujours actives. Avant toute opération sur la batterie, enlever les objets métalliques et s'assurer qu'aucun objet ne puisse tomber sur la batterie elle-même. Toujours utiliser des équipements isolés. Ne pas placer d'objets sur les batteries.

L'électrolyte est un liquide hautement corrosif (acide sulfurique) pouvant provoquer des brûlures graves. En cas de contact accidentel avec les yeux, rincer abondamment avec de l'eau et consulter un médecin.

Les batteries en charge émettent un mélange explosif d'hydrogène et de dioxygène. Risque d'explosions et de déflagrations.

Ne recharger les batteries que dans des zones ventilées. Avant d'effectuer la recharge, ouvrir le couvercle du logement de la batterie.

Le kit de premier secours et l'extincteur doivent être rangés dans un endroit facile d'accès.







1. Installation de batteries chargées
Effectuer la connexion correcte (polarité) des câbles et le serrage des vis: 10 +/- 1 Nm.
Recharger la batterie (Voir point 3).

2. Utilisation
S'assurer que les feintes d'aération ne sont pas obstruées avant l'utilisation. Ne pas ouvrir ni fermer les contacts durant les phases de charge ou de décharge. Éviter les décharges profondes de plus de 80% de la capacité nominale. Les décharges profondes compromettent le bon fonctionnement et la durée de vie de la batterie. Après la phase de décharge, la batterie doit être rechargée dans les plus brefs délais.

3. Charge
A la fin de la période de travail, charger la batterie de façon sûre et recharger dans des endroits exclusivement prévus à cet effet et bien aérés, conformément à la norme EN 50272-3.

4. Nettoyage
Les capots des différents éléments doivent rester fermés.
Le nettoyage de la batterie est particulièrement important pour son bon fonctionnement. Il est donc nécessaire de nettoyer et de sécher soigneusement les couvercles et toutes les parties externes.

5. Batteries stockées
Les batteries non utilisées doivent être stockées dans un endroit couvert, à l'abri de l'humidité, de la poussière et du gel. Effectuer des contrôles et des recharges périodiques, au moins une fois par mois. Il est recommandé de ne jamais laisser les batteries déchargées plus de 2 jours avec une tension inférieure à 2,05 Vpc, et d'effectuer des charges complètes avant de longues périodes d'inactivité.

6. Mauvais fonctionnements et défauts
En cas de mauvais fonctionnements ou de défauts de la batterie, contacter immédiatement le service après-vente. Les valeurs de tension et de densité relatives (voir point 6.3) seront utiles afin d'identifier l'anomalie.

LA GARANTIE EST ANNULÉE EN CAS DE:
Non-respect des présentes instructions pour l'utilisation et l'entretien.
Interventions effectuées par du personnel non autorisé.
Utilisation de composants non d'origine.
Batteries ouvertes; adjonctions de substances chimiques dans l'électrolyte autres que l'eau déminéralisée.
Batteries VRLA: enlèvement des vannes (ouverture de la batterie).

6.1. Quotidien
Après une phase de décharge, recharger la batterie.

Batteries ouvertes - VLA: seulement après une période de recharge, vérifier le niveau de l'électrolyte et, si nécessaire, remettre à niveau avec de l'eau déminéralisée.



NORMAS DE USO Y MANTENIMIENTO DE BATERIAS TIPO FORCEBLOCK

- Referencias normativas:**
EN 50272-3 - REQUISITOS DE SEGURIDAD PARA BATERIAS DE ACUMULADORES Y SUS INSTALACIONES.
- Datos batería**
1. Tensión nominal (V): ver etiqueta 1,70 Vpc
 2. Capacidad nominal C₂₀: ver etiqueta 30°C
 3. Corriente nominal de descarga: C_{2/5}

LAS BATERIAS Y LOS ELEMENTOS SON PESADOS. RESPECTAR LAS RECOMENDACIONES DE SEGURIDAD Y UTILIZAR EQUIPOS ADECUADOS.

Utilizar gafas y prendas de protección para trabajar en las baterías.

No fumar. No utilizar llamas libres, evitar cortocircuitos y cualquier fuente de chispas en la zona de la batería y en la zona de recarga.

¡ATENCIÓN! Todas las partes metálicas de la batería siempre están activas. Antes de cualquier operación en la batería, retirar todos los objetos metálicos y asegurarse de que ningún objeto pueda caer sobre la batería. Utilizar siempre herramientas aisladas. No apoyar objetos sobre las baterías.

El electrolyto es un líquido altamente corrosivo (ácido sulfúrico) que puede provocar graves quemaduras. En caso de contacto accidental con los ojos, lavar con abundante agua corriente y consultar a un médico.

Las baterías en carga emiten una mezcla explosiva de hidrógeno y oxígeno. Riesgo de explosiones y deflagraciones.

Las baterías deben recargarse exclusivamente en áreas ventiladas. Antes de iniciar las operaciones de recarga, abrir la tapa del alojamiento de la batería.

El kit de primeros auxilios y el extintor deben estar en un lugar fácilmente accesible.







1. Instalación de baterías cargadas
Verificar la correcta conexión (polaridad) de los cables terminalitas y el apriete de los tornillos: 10,1 Nm.
Proceder a la carga de la batería (ver el punto 3).

2. Uso
Asegurarse de que durante el uso las aberturas de aireación no estén obstruidas. No abrir o cerrar contactos durante las fases de carga y descarga. Evitar las descargas profundas, superiores al 80% de la capacidad nominal. Las descargas profundas perjudican el buen funcionamiento y la duración de la batería. Después de la descarga, la batería se debe recargar cuanto antes.

3. Carga
Al finalizar el turno de trabajo, cargar la batería de la siguiente manera:
-recargar la carga en lugares destinados exclusivamente para tal fin y bien aislados, de conformidad con la norma EN 50272-3.

4. Limpieza
-limpiar la tapa del alojamiento de la batería;
-efectuar la carga exclusivamente con el cargador previamente definido;
-conectar la batería al cargador respetando las polaridades y comenzar la carga.

5. Baterías almacenadas
La limpieza de la batería es particularmente importante para su buen funcionamiento. Por lo tanto, es necesario secar y limpiar bien las tapas y todas las partes externas.

6. Baterías en almacén
Las baterías no utilizadas se deben guardar en un ambiente cubierto, seco, no polvoriento y protegido de las heladas. Realizar controles y recargas periódicamente, al menos cada mes. Se recomienda no dejar las baterías más de 30 días sin carga con una tensión inferior a 2,05 Vpc, y efectuar cargas completas antes de largos periodos de inactividad.

7. Desperfectos de funcionamiento y defectos
En caso de desperfectos de funcionamiento o defectos en la batería, contactar inmediatamente con el servicio de asistencia. Los valores de tensión y densidad observados (ver el punto 6.3) serán útiles para identificar el fallo.

LA GARANTIA QUEDA SIN EFECTO EN CASO DE:
Incumplimiento de estas instrucciones de uso y mantenimiento.
Intervenciones de personal no autorizado.
Estruque de las baterías o VLA añadido al electrolyto de cualquier sustancia química que no sea agua desmineralizada;
Baterías VRLA: desmontaje de las válvulas (apertura de la batería).

6.1. Diario
Después de una fase de descarga, recargar la batería.

Baterías abiertas - VLA: solamente después de un período de recarga, verificar el nivel de electrolito y, si es necesario, rellenar con agua desmineralizada.

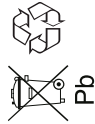

FORCEblock

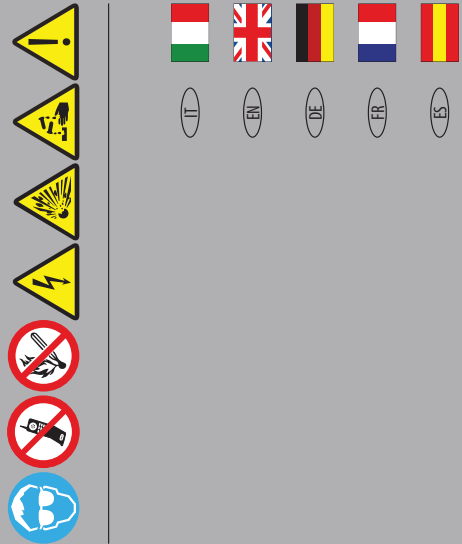

NORME PER L'UTILIZZO E LA MANUTENZIONE DI BATTERIE TIPO FORCEBlock

Riferimenti normativi:
 DIN EN 50272-3 - REQUISITI DI SICUREZZA PER BATTERIE DI ACCUMULATORI E LORO INSTALLAZIONI.
 Dati batteria:
 1. Tensione nominale (V): vedi etichetta 1,70 Vpc
 2. Capacità nominale C₂₀: vedi etichetta 30°C
 3. Corrente nominale di scarica: C/5

LE BATTERIE E GLI ELEMENTI SONO PESANTI. RISPETTARE LE RACCOMANDAZIONI DI SICUREZZA ED UTILIZZARE ATTREZZATURE ADEGUATE.

L'elettrolita è un liquido altamente corrosivo (acido solforico) in grado di provocare serie ustioni. In caso di contatto accidentale con gli occhi o con la pelle, lavare immediatamente con acqua corrente e consultare un medico.

Le batterie in carica emettono una miscela esplosiva di idrogeno e ossigeno. Rischio di esplosioni e deflagrazioni.

Le batterie devono essere ricaricate esclusivamente in aree ventilate. Prima di iniziare le operazioni di ricarica aprire il coperchio del vano batteria.

Il kit di primo soccorso e l'estintore devono essere posizionati in un luogo facilmente accessibile.

ATTENZIONE! Tutte le parti metalliche della batteria sono sempre attive. Prima di ogni operazione sulla batteria rimuovere tutti gli oggetti metallici e assicurarsi che nessun oggetto possa cadere sulla batteria. Utilizzare sempre strumenti isolati. Non posizionare oggetti sulle batterie.

1. Installazione di batterie cariche
 Verificare il corretto collegamento (polarità) dei cavi terminali ed il serraggio delle viti: 10x1 Nm.
 Evitare e alla carica della batteria (vedi punto 3).

2. Utilizzo
 Accentrarsi che durante l'utilizzo le aperture d'aerazione non siano ostruite. Non aprire o chiudere contatti durante le fasi di carica o scarica. Evitare scariche profonde (al 100% della capacità nominale). Le scariche profonde pregiudicano il buon funzionamento e la durata della batteria. Dopo la fase di scarica la batteria deve essere quanto prima ricaricata.

3. Carica
 Al termine del lavoro, caricare la batteria come segue:
 -effettuare la carica in luoghi esclusivamente a ciò destinati e ben areati, in conformità alla norma EN 50272-3;
 -aprire il coperchio del vano batteria.
 I tappeti sui singoli elementi devono rimanere chiusi; -eseguire la carica esclusivamente con il carica-batterie; -collegare la batteria al caricabatteria rispettando le polarità ed iniziare la carica.

3.1. Carica di equalizzazione
 La carica di equalizzazione, che deve essere eseguita almeno due volte al mese al termine della normale fase di carica, contribuisce a mantenere efficiente la batteria ed è particolarmente indicata dopo utilizzi con scariche profonde o ricariche incomplete.

3.2. Carica di manutenzione
 La carica di manutenzione, che deve essere eseguita almeno una volta al mese, contribuisce a mantenere efficiente la batteria ed è particolarmente indicata dopo utilizzi con scariche profonde o ricariche incomplete.

4. Elettrolito (batterie tipo aperto - VLA)
 La densità nominale dell'elettrolito, riferita a 30°C è 1,29 ± 0,01 kg/L.

N.B.: Temperature superiori a 30°C riducono la densità dell'elettrolito e temperature inferiori la aumentano. Il fattore di correzione è di 0,0007 kg/L per grado C.

5. Temperatura
 Es, ad una densità di 1,26 kg/L, rilevata alla temperatura di 45°C, corrisponde una densità di 1,27 kg/L a 30°C.

6. Manutenzione
 La temperatura nominale è di 30°C e, salvo specifica valutazione preventiva, deve rimanere compresa tra +5°C e +45°C durante l'esercizio.

N.B.: Temperature elevate accorciano la durata della batteria e temperature basse ne diminuiscono l'efficienza.

7. Manutenzione
 Mancauto rispetto delle presenti istruzioni d'uso e manutenzione. Interventi effettuati da personale non autorizzato. Le batterie VLA, essendo un elettrolito di qualsiasi sostanza chimica ad eccezione di acqua demineralizzata, richiedono la presenza di un liquido di carica. VLA: immissione delle valvole (apertura della batteria).

8. Manutenzione
 Dopo una fase di scarica, ricaricare la batteria.

Batterie tipo aperto - VLA: esclusivamente dopo una fase di ricarica, verificare il livello dell'elettrolito solo se necessario rabboccare con acqua demineralizzata.

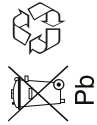

INSTRUCTIONS FOR THE USE AND MAINTENANCE OF FORCEBlock BATTERIES

Reference standards:
 DIN EN 50272-3 - SAFETY REQUIREMENTS FOR BATTERIES AND BATTERY INSTALLATIONS.
 Battery specifications:
 1. Nominal voltage (V): see label 1,70 Vpc
 2. Nominal capacity C₂₀: see label 30°C
 3. Nominal discharge current: C/5

BATTERIES AND CELLS ARE HEAVY. FOLLOW THE SAFETY INSTRUCTIONS AND USE SUITABLE EQUIPMENT.

The electrolyte is a highly corrosive liquid (sulfuric acid) that may cause serious burns. In case of contact with the eyes or skin, rinse thoroughly with large quantities of running water and seek medical attention.

Batteries being charged emit an explosive mixture of hydrogen and oxygen. Risk of explosion.

Batteries should only be charged in ventilated areas. Open the cover on the battery compartment before recharging.

A first-aid kit and fire extinguisher should be positioned in an easily-accessible area.

CAUTION! All metal parts on the battery are permanently live. Remove all metal objects and ensure that nothing can fall onto the battery before carrying out any operation on the battery. Always use insulated tools. Do not place anything on the batteries.

1. Installing charged batteries
 Check that the terminal cables are correctly connected (polarity), and that the bolts are tightened: 10x1 Nm.
 Start charging the battery (see point 3).

2. Use
 Make sure the air vents do not become obstructed during use. Do not open or close the contacts during charging or discharging. Avoid deep discharges greater than 80% of nominal capacity. Deep discharges compromise battery operation and shorten battery life. The battery should be recharged as soon as possible following discharge.

3. Charging
 At the end of the work shift, charge the battery as follows:
 -only charge the batteries in well ventilated areas dedicated to this purpose, in compliance with Standard EN 50272-3;
 -open the cover of the battery compartment.
 Only charge the batteries using the battery charger -connect the battery to the battery charger observing the correct polarity and begin charging.

3.1. Equalize charge
 The equalize charge should be carried out at least twice a month following the normal charging cycle. It contributes to maintaining the battery's efficiency and is particularly recommended following use with deep discharges or incomplete recharging cycles.

3.2. Maintenance charge
 The maintenance charge, which must be carried out at least once a month, contributes to maintaining the battery's efficiency and is particularly recommended following use with deep discharges or incomplete recharging cycles.

4. Electrolyte (open batteries - VLA)
 The nominal density of the electrolyte at 30°C is 1.29 ± 0.01 kg/L.

N.B.: Temperatures higher than 30°C reduce the density of the electrolyte and lower temperatures increase it. The correction factor is 0.0007 kg/L per degree C.

5. Temperature
 E.g. a density of 1.26 kg/L, measured at a temperature of 45°C, corresponds with a density of 1.27 kg/L at 30°C.

6. Maintenance
 The nominal temperature of the electrolyte is 30°C and should remain between +5°C and +45°C during operation, except in the event of a specific prior assessment.

N.B.: Temperatures higher than 30°C reduce the density of the electrolyte and lower temperatures increase it. The correction factor is 0.0007 kg/L per degree C.

7. Maintenance
 Failure to comply with these instructions for use and maintenance. Operations carried out by unauthorised personnel. The use of non-original components. VLA batteries: the addition to the electrolyte of any chemical substances other than demineralised water.

8. Maintenance
 After a discharge cycle, recharge the battery.

Open batteries - VLA: check the electrolyte level only following charge cycle, top up with demineralised water only if necessary.

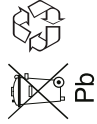

BETRIEBS- UND WARTUNGSANLEITUNG FÜR BATTERIEN DES TYPUS FORCEBlock

Normenbezug:
 DIN EN 50272-3 - SICHERHEITSAUFORDERUNGEN AN BATTERIEN UND BATTERIEANLAGEN.
 Kennwerte der Batterie:
 1. Nennspannung (V): Siehe Typenschild 1,70 Vpc
 2. Nennkapazität C₂₀: Siehe Typenschild 30°C
 3. Nennentladestrom: C/5

BATTERIEN UND BATTERIEZELLEN SIND SCHWER. DIE SICHERHEITSSCHWELLEN ERHALTEN MIT DEN BEGRIFFEN "HEAVY" VERWENDEN.

Der Elektrolyt ist eine stark ätzende Flüssigkeit (Schwefelsäure), die schwere Verätzungen verursachen kann. Bei Augen oder Haut Kontakt mit viel klarem Wasser abspülen und ärztliche Hilfe anfordern. Das Laden von Batterien setzt ein explosives Gasgemisch aus Wasserstoff und Sauerstoff frei. Es besteht Explosions- und Verpuffungsgefahr. Batterien dürfen nur in ausreichend belüfteten Räumen aufgeladen werden. Vor dem Ladegang den Deckel des Batteriefachs öffnen.

Bei Arbeiten an Batterien sind Schutzkleidung tragen.

Nicht rauchen. Keine offenen Flammen verwenden, Kurzschlüsse und Funkenbildung in der Nähe der Batterie sowie im gesamten Ladebereich vermeiden.

ACHTUNG! Sämtliche Metallteile der Batterie stehen permanent unter Spannung. Vor Arbeiten an der Batterie alle Metallgegenstände entfernen und sicherstellen, dass keine Gegenstände auf die Batterie fallen können. Ausschließlich isolierte Werkzeuge verwenden. Keine Gegenstände auf Batterien ablegen.

1. Inbetriebnahme geladener Batterien
 Den polrichtigen Anschluss der Endkabel und den Festzurr der Schrauben vor Stecken und Abstreifen des Schutzkabels (siehe Punkt 3).
6.2. Wöchentliche Wartung
 Eine Schprüfung der Batterie vornehmen und eine Ausgleichsladung durchführen.

2. Betrieb der Batterie
 Bei Betrieb stets sicherstellen, dass die Lüftungsoffnungen nicht verschlossen oder verdeckt werden. Die Kontakte nur in stromlosem Zustand öffnen und schließen. Tiefentladungen von mehr als 80 % der Nennkapazität vermeiden. Tiefentladungen beeinträchtigen den stromstren Betrieb und die Lebensdauer der Batterie. Nach einer Entladeperiode muss die Batterie so rasch wie möglich wieder aufgeladen werden.

3. Laden der Batterie
 Die Batterie nach jeder Arbeitsschicht wie folgt aufladen:
 -Den Ladegang ausschließlich an einem dafür vorgesehenen, gut belüfteten Ort ausführen, siehe hierzu die Vorgaben der Norm DIN EN 50272-3.
 -Den Deckel des Batteriefachs öffnen, die Verschlüsse der einzelnen Batteriezellen jedoch geschlossen halten.
 -Die Batterie ausschließlich mit der dafür vorgesehenen Batterieaufladestation laden.
 -Die Ladestation, Pöschung an des Ladegerät anschließen und den Ladegang starten.

3.1. Ausgleichsladung
 Die Ausgleichsladung der Batterie muss mindestens zweimal pro Monat nach dem normalen Ladegang vorgenommen werden. Dies hilft, die Leistungsfähigkeit der Batterie zu erhalten und ist vor allem nach einem Betrieb mit Tiefentladungen oder unvollständigen Ladeprozessen sinnvoll.

3.2. Wartungsladung
 Die Wartungsladung, die mindestens einmal pro Monat vorgenommen werden muss, trägt zur Erhaltung der Leistungsfähigkeit der Batterie bei und ist insbesondere nach tiefen Entladungen oder unvollständigen Ladeprozessen sinnvoll.

4. Elektrolyt (offene Batterie - VLA)
 Die Nennichte des Elektrolyten bei 30 °C beträgt 1,29 ± 0,01 kg/L.

N.B.: Bei Temperaturen über 30 °C ist die Dichte des Elektrolyten geringer, bei Temperaturen unter 30 °C ist die Dichte höher. Der Korrekturfaktor beträgt 0,0007 kg/L pro Grad Celsius.

5. Temperatur
 Zum Beispiel entspricht eine bei 45 °C gemessene Dichte von 1,26 kg/l einer Dichte bei 30 °C von 1,27 kg/l.

6. Wartung
 Die Nenntemperatur des Elektrolyten beträgt 30 °C. Außer in Sonderfällen, die vorab vom Hersteller beurteilt und genehmigt werden, muss die Temperatur bei Betrieb im Bereich von +5 °C bis +45 °C liegen.

N.B.: Bei Temperaturen über 30 °C ist die Dichte des Elektrolyten geringer, bei Temperaturen unter 30 °C ist die Dichte höher. Der Korrekturfaktor beträgt 0,0007 kg/L pro Grad Celsius.

7. Temperatur
 Zum Beispiel entspricht eine bei 45 °C gemessene Dichte von 1,26 kg/l einer Dichte bei 30 °C von 1,27 kg/l.

8. Temperatur
 Die Nenntemperatur des Elektrolyten beträgt 30 °C. Außer in Sonderfällen, die vorab vom Hersteller beurteilt und genehmigt werden, muss die Temperatur bei Betrieb im Bereich von +5 °C bis +45 °C liegen.

DER GARANTIEANSPRUCH ERLICHT IN FOLGENDEN FÄLLEN:
 Nichterhaltung dieser Betriebs- und Wartungsanleitung. Eingriffe, die von nicht autorisiertem Personal vorgenommen werden. Verwendung von Nicht-Original-Ersatzteilen. Batterien des Typs VLA: Zugabe chemischer Stoffe zum Elektrolyten mit Ausnahme von demineralisiertem Wasser. Entfernen des Ventils (Öffnen der Batterie).

9. Störungen und Defekte
 Bei Störungen oder Defekten der Batterie umgehend den Kundendienst kontaktieren. Die ungezielten Spannungs- und Dichtewerte (siehe Punkt 6.3) erleichtern und verkürzen die Fehlersuche.

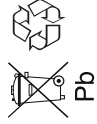

10.5. BATTERY DOCUMENTATION EXIDE

Shown below are the directions for use provided directly by the manufacturer of the commercial device, standard or optional, installed on the machine.
The language of such documentation may not correspond to that in which the machine's directions for use are written.

81700679

Lead acid bloc batteries with positive flat plates (GiS) and positive tubular plates (PzS)

Range: FF and FT

Maintenance free lead acid bloc batteries with positive flat plates (GiV)

Range: GF-V, GF-Y, AF-X, AF-Z, AS, df-V und df-Y

Operating Instructions

Traction batteries

Rating data

- Nominal capacity C_5 :see type plate
- Nominal voltage U_N :see type plate
- Nominal current $I_N=I_5$: $C_N/5h$
- Nominal S.G. of electrolyte*
 - Type GiS-Bloc :1,28 kg/l
 - Type PzS-Bloc :1,29 kg/l
 - Type GiV-Bloc :the electrolyte is immobilised, the density of the electrolyte can not be measured
- Rated temperature :30° C
- Nominal electrolyte level** :up to electrolyte level mark "max." or cover at least the separators

* Will be reached within the first 10 cycles.

** GiV batteries are valve-regulated batteries (VRLA) with an immobilised electrolyte, where a water refilling isn't permitted during the whole battery life. Instead of vent plugs, valves are used, which will be destroyed when they are opened. When operating valve-regulated lead-acid batteries the same safety requirements as for vented cells apply to protect against hazards from electric current, from explosion of electrolytic gases and, in case of the cell container is damaged, from the corrosive electrolyte.



- Pay attention to the "instructions for use" and fix them close to the battery.
- Work on the battery should only be carried out by qualified personnel.



- Use protective glasses and clothes when working on batteries. Pay attention to the accident prevention rules as well as EN 50272-3, EN 50110-1.



- No smoking!
Do not expose batteries to naked flames, glowing embers or sparks, as it may cause the battery to explode.



- Keep children away from batteries!



- Acid splashes in the eyes or on the skin must be washed with water. In case of accident consult a doctor immediately.
- Clothing contaminated by acid should be washed in water



- Risk of explosion and fire, avoid short circuits.



- Electrolyte is highly corrosive.
- In the normal operation of GiV batteries a contact with acid isn't possible. If the cell containers are damaged, the immobilised electrolyte (gelled sulphuric acid) is corrosive like the liquid electrolyte.



- Do not spin battery!
- Ensure secure installation. Use only suitable handling equipment e.g. lifting gear in accordance with VDI 3616. Avoid damage to the batteries, connectors or end cables with the lifting equipment.



- Dangerous electrical voltage!
Caution! Metal parts of the battery are always alive. Do not place tools or other metal objects on the battery.

Ignoring the operation instructions, repair with non-original parts or using additives for the electrolyte will render the warranty void.

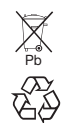

Spent batteries have to be collected and recycled separately from normal household wastes (EWC 160601). The handling of spent batteries is described in the EU Battery Directive (91/157/EEC) and their national transitions (UK: HS Regulation 1994 No. 232, Ireland: Statutory Instrument No. 73/2000). Contact your supplier to agree upon the recollection and recycling of your spent batteries or contact a local and authorized Waste Management Company.

1. Commissioning filled and charged batteries

The battery should be inspected to ensure it is in perfect physical condition. Before installing the

battery compartment has to be cleaned. Only blocks with the same state of discharge (the same voltage, tolerance like the following table) have to be connected together.

Nominal bloc voltage [V]	Max. tolerance from average value - ΔU_{Bloc} [V]
2	± 0.020
4	± 0.028
6	± 0.035
8	± 0.040
12	± 0.049

The battery end cables must have a good contact to terminals, check that the polarity is correct. Otherwise battery, vehicle or charger could be destroyed. After connecting cover the end poles with grease as external corrosion protection.

The level of the electrolyte must be checked. If it is below the electrolyte level mark "min." or the top of the separator, it must first be topped up to this height with purified water (**only GiS/ PzS-batteries**).

The battery is then charged as in item 2.2.

The electrolyte should be topped up to the specified level with purified water (DIN 43530 part 4). (**only GiS/ PzS-batteries**).

The specified torque loading for the pole screws of the end cables and connectors are:

Terminal	Nomenclature	Tightening Torque Value
EN (A) conical	-	$8 \pm 1Nm$
Flat M5 (G5) / M6 (G6)	F / G	$5 / 6 \pm 1Nm$
Screw type (male) M8 / M10	M / N	$11 / 17 \pm 1Nm$
Screw type (female) M6 / M8 / M10	O / P* / Q	$8 / 20 / 20 \pm 1Nm$
WNT 3/8"-16 , 5/16"-18	W	$16 \pm 1Nm$
Combination of EN (A) conical and Stud 3/8"	R	$8 \pm 1 Nm$ $16 \pm 1Nm$

*Exception GF 06 095 V P4:

⇔ Tightening Torque = $12 \pm 1Nm$

Example for description: GF 06 180 V P

⇔ Screw type terminal (female) M8

⇔ Tightening Torque = $20 \pm 1Nm$

For commissioning of unfilled **GiS/PzS-batteries** see separate instructions.

2. Operation

EN 50272-3 "Traction batteries for industrial trucks" is the standard, which applies to the operation traction batteries in industrial trucks.

2.1 Discharging

Ventilation openings must not be sealed or covered.

Electrical connections (e.g. plugs) must only be made or broken in the open circuit condition. To achieve the optimum life for the battery, operating discharges of more than 80% of the rated capacity should be avoided (deep discharge).

This corresponds to an electrolyte specific gravity of 1.13 kg/l at the end of the discharge (**only GiS/ PzS-batteries**).

To measure the state of discharge use only the battery manufacturer recommended discharge indicators.

Discharged batteries must be recharged immediately and must not be left discharged. This also applies to partially discharged batteries. Otherwise the life of battery will be reduced.

2.2 Charging

Only direct current must be used for charging. All charging procedures in accordance with DIN 41773 and DIN 41774 are permitted.

For **GiV-batteries** these charging procedures must only be applied in the manufacturer approved modifications. Therefore only battery manufacturer approved chargers must be used.

Only connect the battery assigned to a charger, suitable for the size of battery, in order to avoid overloading of the electric cables and contacts and unacceptable gassing of the cells.

GiV-batteries have a low gas emission.

In the gassing stage the current limits given in EN 50272-3 must not be exceeded. If the charger was not purchased together with the battery it is best to have its suitability checked by the manufacturer's service department.

When charging, proper provision must be made for venting of the charging gases. Battery container lids and the covers of battery compartments must be opened or removed. The vent plugs should stay on the cells and remain closed.

With the charger switched off connect up the battery, ensuring that the polarity is correct (positive to positive, negative to negative). Now switch on the charger.

When charging the temperature of the battery rises by about 10 K, so charging should only begin if the battery temperature is below 35° C (**GiV**) or 45° C (**GiS/PzS**). The electrolyte temperature of batteries should be at least + 15° C (**GiV**) or +10° C (**GiS/PzS**) before charging. Otherwise a full charge will not be achieved.

For **GiS/PzS-batteries** a charge is finished when the specific gravity of the electrolyte and the battery voltage have remained constant for two hours.

For **GiV-batteries** only regulated chargers are permitted. These chargers switch off automatically. Are the temperatures a longer time higher than 40° C or lower than 15° C, so the chargers need a temperatures regulated voltage. (Attend to instructions of battery manufacturer).

2.3 Equalising charge

Equalising charges are used to safeguard the life of the battery and to maintain its capacity. They are necessary after deep discharges, repeated incomplete recharges and charges to an IU characteristic curve. Equalising charges are carried out following normal charging.

For equalising charge of **GiV-batteries** only battery manufacturer approved chargers must be used.

For **GiS/PzS-batteries** the charging current must not exceed 5 A/100 Ah of rated capacity (end of charge – see point 2.2).

Watch the temperature!

2.4 Temperature

An electrolyte temperature of 30° C is specified as the rated temperature. Higher temperatures shorten the life of the battery, lower temperatures reduce the capacity available.

45° C (**GiV**) or 55° C (**GiS/PzS**) is the upper temperature limit and is not acceptable as an operating temperature.

Therefore the batteries should not be left in directly sunlight.

2.5 Electrolyte

GiV-Batteries: The electrolyte is immobilised. The density of the electrolyte cannot be measured.

GiS/PzS-Batteries: The rated specific gravity (S. G.) of the electrolyte is related to a temperature of 30° C and the nominal electrolyte level in the cell in fully charged condition.

Higher temperatures reduce the specified gravity of the electrolyte, lower temperatures increase it. The temperature correction factor is -0.0007 kg/l per K, e.g. an electrolyte specific gravity of 1.28 kg/l at 45° C corresponds to an S.G. of 1.29 kg/l at 30° C. The electrolyte must conform to the purity regulations in DIN 43530-2.

3. Maintenance

Do not refill with water in GiV-Batteries!

3.1 Daily

Charge the battery immediately after every discharge.

GiS/PzS-batteries: Towards the end of charge the electrolyte level should be checked and if necessary topped up to the specified level with purified water. The electrolyte level must not fall below the top of the separator or the electrolyte "min" level mark.

3.2 Weekly

Visual inspection after recharging for signs of dirt and mechanical damage. If the battery is charged regularly with an IU characteristic curve an equalising charge must be carried out (see point 2.3).

3.3 Monthly (only GiS/PzS-batteries)

At the end of the charge the voltages of all cells or bloc batteries should be measured with the charger switched on, and recorded.

After charging has ended the specific gravity and the temperature of the electrolyte in all cells should be measured and recorded. If significant changes from earlier measurements or differences between the cells or bloc batteries are found

further testing and maintenance by the service department should be requested.

3.4 Quarterly (only GiV-batteries)

After the end of the charge and a rest time of 5 h following should be measured and recorded:

- the voltages of the battery
- the voltages of every cells or blocs

If significant changes from earlier measurements or differences between the cells or bloc batteries are found, further testing and maintenance by the service department should be requested.

3.5 Annually (only for batteries in steel trays)

In accordance with EN 1175-1 at least once per year, an electrical specialist must check the insulation resistance of the truck and the battery.

The tests on the insulation resistance of the battery must be conducted in accordance with EN 1987-1.

The insulation resistance of the battery thus determined must not be below a value of 50 Ω per Volt of nominal voltage, in compliance with EN 50272-3.

For batteries up to 20 V nominal voltage the minimum value is 1000 Ω.

4. Care of the battery

The battery should always be kept clean and dry to prevent tracking currents. Cleaning must be done in accordance with the ZVEI code of practice "The Cleaning of Vehicle Traction batteries".

5. Storage

If batteries are taken out of service for a lengthy period they should be stored in the fully charged condition in a dry, frost-free room. To ensure the battery is always ready for use a choice of charging methods can be made:

- a quarterly (**GiS/PzS**) or a yearly (**GiV**) full charging like charge as in point 2.2. If any consumer is connected with, e.g. measure or controlling systems, it can be, that this charging is necessary every 14 days.
- float charging at a charging voltage of 2.25 V (**GiS/PzS**) or 2,3 V (**GiV**) x the number of cells. The storage time should be taken into account when considering the life of the battery.

6. Malfunctions

If malfunctions are found on the battery or the charger our service department should be called without delay. The measurements taken in point 3.3 will facilitate fault finding and their elimination.

A service contract with us will make it easier to detect and correct faults in good time.

MXEBB0E00000304 - Hellersche Druckerei - Printed in Germany - Subject to change
81700679 2.11.05

State: September 2004

Deutsche EXIDE GmbH
Im Thiergarten
63654 Büdingen – Germany

Tel.: +49 (0) 60 42 / 81 454

Fax: +49 (0) 60 42 / 81 398

www.industrialenergy.exide.com

EXIDE
TECHNOLOGIES
INDUSTRIAL ENERGY

Operating Instructions

Traction Batteries with Dry-Charged Cells

■ OPERATION

- a) Open plugs.
- b) Pour in the electrolyte at a temperature between 15° and 30° C, at a density of 1.270 - 1.280 kg/l. Make sure the level of the electrolyte is between 5 - 7 mm above the height of the separators in each cell.
- c) After approximately one hour, if necessary, top up the electrolyte level again, as it may have been partially absorbed by the plates.
- d) Connect positive and negative poles to the rectifier. Make sure the polarity is correct.
- e) Let the battery rest for about 4 hours, then charge at a current intensity about 1/10 of the rated capacity of battery, proceeding for the time required to reach a voltage of about 2,7 V in each cell, and a density of 1.280 - 1.290 kg/l at 25° C (approximately, from 5 to 15 hours, at most. For example: 24V - 480 Ah battery charging current 48 A).
- f) The battery temperature must never exceed 45° C during charging. If this threshold is exceeded, gradually reduce the current intensity until an acceptable temperature is reached (around 30° C).
- g) When charging is finished, the density of the electrolyte must be the same for each cell, and be between 1,280 - 1,290 kg/l, at 30° C.
- h) Leave the plugs open during charging of the battery in order to allow any gasses to dissipate (oxygen and hydrogen).
- i) Close the plugs and clean the upper part of the battery carefully.
- l) The temperature of the environment affects the density of the electrolyte.
- m) The temperature of the environment affects the Ah capacity supplied by the battery. Every increase or decrease with respect to 30° C affects the performance of the battery.

10.6. BATTERY DOCUMENTATION MIDAC

Shown below are the directions for use provided directly by the manufacturer of the commercial device, standard or optional, installed on the machine.
The language of such documentation may not correspond to that in which the machine's directions for use are written.

FR





NORMES POUR L'UTILISATION ET L'ENTRETIEN DES BATTERIES FORCEBLOCK

Normes de référence:
EN 50272-3 - CONDITIONS DE SÉCURITÉ REQUISES POUR LES BATTERIES D'ACCUMULATEURS ET LEUR INSTALLATION

Données de la batterie



1. Tension nominale (V): voir étiquette
2. Capacité nominale C₁₀₀: voir étiquette
3. Courant nominal de décharge: C₁₀/5

4. Température de fin de décharge: 1.70 Vpc
5. Température nominale: 30°C

L'électrolyte est un liquide hautement corrosif (acide sulfurique) pouvant provoquer des brûlures graves. En cas de contact accidentel avec les yeux ou la peau, laver abondamment avec de l'eau et consulter un médecin. Éviter l'inhalation d'un mélange explosif d'hydrogène et d'oxygène. Risque d'explosion et de déflagrations.

Ne recharger les batteries que dans un environnement sûr et approprié. Ne rechargez, ouvrez la couverture du logement de la batterie.

Le kit de premier secours doit être rangé dans un endroit facile d'accès.

ATTENTION! Les parties métalliques de la batterie sont toujours actives. Avant toute opération sur la batterie, élever les objets métalliques et s'assurer qu'aucun objet ne puisse tomber sur la batterie elle-même. Toujours utiliser des équipements isolés. Ne pas placer d'objets sur les batteries.

ES





NORMAS DE USO Y MANTENIMIENTO DE BATERIAS TIPO FORCEBLOCK

Referencias normativas:
EN 50272-3 - REQUISITOS DE SEGURIDAD PARA BATERIAS DE ACUMULADORES Y SUS INSTALACIONES.

Datos batería

1. Tensión nominal (V): ver etiqueta
2. Capacidad nominal C₁₀₀: ver etiqueta
3. Corriente nominal de descarga: C₁₀/5



4. Temperatura de fin de descarga: 1.70 Vpc
5. Temperatura nominal: 30°C

El electrolito es un líquido altamente corrosivo (ácido sulfúrico) que puede provocar quemaduras graves. En caso de contacto accidental con los ojos o la piel, lavar abundantemente con agua corriente y consultar a un médico.

Las baterías en carga emiten una mezcla explosiva de hidrógeno y oxígeno. Riesgo de explosiones y deflagraciones.







Las baterías deben recargarse en un lugar seguro y apropiado. Antes de iniciar las operaciones de recarga, abrir la tapa del alojamiento de la batería.















El kit de primeros auxilios debe estar disponible en un lugar fácilmente accesible.

¡ATENCIÓN! Todas las partes metálicas de la batería siempre están activas. Antes de cualquier operación en la batería, retirar todos los objetos metálicos y asegurarse de que ningún objeto pueda caer sobre la batería. Utilizar siempre herramientas aisladas. No apoyar objetos sobre las baterías.

FORCEblock MIDAC

1. Installation de batteries chargées
- Éviter l'insertion incorrecte des câbles et le serrage des vis: 10 +1/-1 Nm.
- Recharger la batterie (voir point 3).

2. Utilisation
- Vérifier le couple de serrage des vis des bornes comme expliqué dans le paragraphe 1.
Batteries ouvertes - VLA:
Au terme d'une phase de charge d'égalisation, contrôler et noter la tension et la densité de chaque élément de la batterie. Vérifier le niveau de l'électrolyte de tous les éléments.

Batteries VRLA:
- Éviter les phases de charge d'égalisation, vérifier et noter la tension de chaque élément de la batterie.

En cas de fortes variations par rapport à la norme EN 50272-3:
- effectuer la charge dans des endroits conformément à la norme EN 50272-3;
- ouvrir le couvercle de l'emplacement réservé à la batterie.

Après des différents éléments doivent rester fermés.
- charger les batteries exclusivement avec le chargeur défini à l'avance;
- brancher la batterie au chargeur en respectant les polarités et lancer la charge.

3.1. Charge d'égalisation
La charge d'égalisation, qui doit être effectuée au moins deux fois par mois à la fin de la charge normale, contribue à préserver l'efficacité de la batterie. Cette charge est particulièrement recommandée pour les batteries VRLA et les batteries déchargées plus de 2 jours avec une tension inférieure à 2,05 Vpc, et d'effectuer des charges complètes avant de longues périodes d'inactivité.

3.2. Mauvais fonctionnements et défauts
En cas de mauvais fonctionnements ou de défauts de la batterie, contacter immédiatement le service après-vente. Les valeurs de tension et de densité indiquées (voir point 6.3) seront utiles afin d'identifier l'anomalie.

LA GARANTIE EST ANNULÉE EN CAS DE D :
- Non-respect des présentes instructions pour l'utilisation et l'entretien.
- Interventions effectuées par du personnel non autorisé.
- Utilisation de composants non d'origine.
- Batteries ouvertes, adjonctions de substances déminéralisées dans l'électrolyte autres que l'eau déminéralisée.
- Batteries VRLA: entèvement des vannes (ouverture de la batterie).

6.1. Quotidien
Après une phase de décharge, recharger la batterie.

Batteries ouvertes - VLA: seulement après une période de recharge, vérifier le niveau de l'électrolyte, le cas échéant, remettre à niveau avec de l'eau déminéralisée.

1. Installation de batteries chargées
- Éviter l'insertion incorrecte des câbles, terminales et le serrage des vis: 10±1 Nm.
- Procéder à la charge de la batterie (voir le point 3).

2. Usage
- Assurer que durant le processus de charge, la batterie ne soit pas surchargée. Au terme d'une phase de charge de décharge, éviter les décharges profondes de plus de 80% de la capacité nominale. Les déchargements profonds compromettent le bon fonctionnement et la durée de vie de la batterie. Après la phase de charge, la batterie doit être rechargée dans les plus brefs délais.

3. Charge
- Éviter les phases de charge d'égalisation, vérifier et noter la tension de chaque élément de la batterie.

Al finalizar el turno de trabajo, cargar la batería de acuerdo a las instrucciones. Evitar la sobrecarga. Al término de una fase de carga de descarga, evitar las descargas profundas de más del 80% de la capacidad nominal. Los descargamientos profundos comprometen el buen funcionamiento y la vida útil de la batería. Después de la carga, la batería se debe recargar cuanto antes.

3.1. Carga
- Evitar las fases de carga de equilibrio, verificar y anotar la tensión y la densidad de cada elemento de la batería.

Al final de una fase de carga de equalización verificar y anotar la tensión y la densidad de cada elemento de la batería.

En caso de variaciones considerables respecto de la verificación anterior, contactar con el servicio de asistencia. Limpiar bien la batería (ver el punto 7).

Verificar la integridad del aislamiento.

7. Limpieza
La limpieza de la batería es particularmente importante para su buen funcionamiento. Por lo tanto, limpiar bien la batería y limpiar bien las tapas y todas las partes externas.

8. Baterías en almacén
Las baterías no utilizadas se deben guardar en un ambiente cubierto, seco, no polvoroso y protegido de los helados. Realizar controles y mantenimiento periódico. Se recomienda no dejar las baterías más de 2 días descargadas o con una tensión inferior a 2,05 Vpc y efectuar cargas completas antes de largos períodos de inactividad.

9. Defectos de funcionamiento y defectos
En caso de defectos de funcionamiento o defectos en la batería, contactar inmediatamente con el servicio de asistencia. Los valores de tensión y densidad observados (ver el punto 6.3) serán útiles para identificar el fallo.

LA GARANTÍA QUEDA SIN EFECTO EN CASO DE:
- Incumplimiento de estas instrucciones de uso y mantenimiento.
- Intervenciones de personal no autorizado.
- Empleo de componentes no originales.
- Cualquier sustancia química que no sea agua desmineralizada.
- Baterías VRLA: desmontaje de las válvulas (apertura de la batería).

Riferimenti normativi:
EN 50272-3 - REQUISITI DI SICUREZZA PER BATTERIE DI ACCUMULATORI E LORO INSTALLAZIONI.

Dati batteria
1. Tensione nominale (V): vedi etichetta
2. Capacità nominale C₂₀: vedi etichetta
3. Corrente nominale di scarica: C/5
4. Tensione di fine scarica: 1,70 Vpc
5. Temperatura nominale: 30°C

LE BATTERIE E GLI ELEMENTI SONO PESANTI. RISPETTARE LE RACCOMANDAZIONI DI SICUREZZA ADEGUATE AT TIREZZATURE

L'elettrolita è un liquido altamente corrosivo (acido sulfonico) in grado di causare gravi ustioni se entrato in contatto accidentale con gli occhi o la pelle. Lavare con abbondante acqua corrente e consultare un medico se necessario. Le batterie in carica emettono una miscela esplosiva di idrogeno e ossigeno. Rischio di esplosioni e delirazioni.

Le batterie devono essere ricaricate esclusivamente in aree ventilate. Prima di iniziare le operazioni di ricarica aprire il coperchio del vano batteria.

Il kit di primo soccorso e le istruzioni possono essere posizionati in un luogo facilmente accessibile.

ATTENZIONE! Tutte le parti metalliche della batteria sono sempre attive. Prima di ogni operazione sulla batteria rimuovere tutti gli oggetti metallici e assicurarsi che nessun oggetto possa cadere sulla batteria. Utilizzare sempre strumenti isolati. Non posizionare oggetti su batterie.

1. Installazione di batterie cariche
Verificare il corretto collegamento (polarità) dei cavi terminali ed il serraggio delle viti: 10x1 Nm.
Procedere alla carica della batteria (vedi punto 3).

2. Utilizzo
Accertarsi che durante l'utilizzo le aperture d'aerazione non siano ostruite. Non aprire o chiudere contatti durante la fase di carica o scarica. Evitare scariche profonde (oltre il 60% della capacità nominale). Le batterie non vanno ricaricate in un luogo chiuso e non in presenza della batteria. Dopo la fase di scarica la batteria deve essere quanto prima ricaricata.

3. Carica
Al termine del turno lavorativo, caricare la batteria come segue:
- effettuare la carica in luoghi esclusivamente a ciò destinati e ben areati, in conformità alla norma EN 50272-3;
- in caso di considerevoli variazioni (rispetto alla verifica precedente) contattare il servizio assistenza (vedere punto 7.1);
- eseguire la carica esclusivamente con il carica-batteria preventivamente definito;

- collegare la batteria al caricabatteria rispettando le polarità ed indicare la carica.

3.1. Carica di equalizzazione.
La carica di equalizzazione, che deve essere eseguita durante la fase di carica, contribuisce a mantenere efficiente la batteria ed è particolarmente indicata dopo utilizzi con scariche profonde o ricariche incomplete.

4. Elettrolito (batterie tipo aperto - VLA)
La densità nominale dell'elettrolito, riferita a 30°C è 1,29 ± 0.01 kg/L.

5. Temperatura
La temperatura nominale è di 30°C e, salvo specifica valutazione preventiva, deve rimanere compresa tra 5°C e 45°C durante l'uso.

N.B.: Temperature superiori a 30°C riducono la densità di elettrolita e di conseguenza la vita della batteria. Il fattore di correzione è di 0,0007 kg/l per grado C.

6. Manutenzione
6.1. **Giornaliera**
Dopo una fase di scarica, ricaricare la batteria.

Batterie tipo aperto - VLA: esclusivamente dopo la fase di scarica, controllare il livello dell'elettrolito e solo se necessario rabboccare con acqua demineralizzata.

7. Pulizia
La pulizia della batteria è particolarmente importante per il suo buon funzionamento ed è pertanto necessario che le superfici esterne e pulite con i coperti e tutte le parti esterne.

8. Batterie a magazzino
Le batterie non utilizzate devono essere mantenute in ambiente coperto, asciutto, non polveroso ed all'incoscienza. Eseguire dei controlli e delle ricariche periodicamente, con frequenza almeno mensile. Si raccomanda di non lasciare mai per più di 2 giorni le batterie scariche, con tensione inferiore a 2,05 Vpc.

9. Manutenzioni e difetti
Qualora fossero riscontrati malfunzionamenti o difetti nella batteria, contattare immediatamente il servizio assistenza. I valori di tensione e densità riferiti (vedi punto 6.3) saranno utili per individuare il guasto.

LA GARANZIA DECADA NEL CASO DI:
Mancato rispetto delle presenti istruzioni d'uso e manutenzione.
Interventi effettuati da personale non autorizzato.
Iniego di componenti non originali.
Batterie VLA: aggiunta all'elettrolito di qualsiasi sostanza chimica ed eccezione di acqua demineralizzata.
Batterie VRLA: rimozione delle valvole (apertura della batteria).



Reference standards:
EN 50272-3 - SAFETY REQUIREMENTS FOR BATTERIES AND BATTERY INSTALLATIONS.

Battery specifications
1. Nominal voltage (V): see label
2. Nominal capacity C₂₀: see label
3. Nominal discharge current: C/5
4. End of discharge voltage: 1.70 Vpc
5. Nominal temperature: 30°C

BATTERIES AND CELLS ARE HEAVY. FOLLOW THE SAFETY INSTRUCTIONS AND USE SUITABLE EQUIPMENT

The electrolyte is a highly corrosive liquid which may cause severe burns if it comes in contact with the eyes or skin, rinse thoroughly with large quantities of running water and seek medical attention.
Batteries being charged emit an explosive mixture of hydrogen and oxygen. Risk of explosion.

Batteries should only be charged in ventilated areas. Open the cover on the battery compartment before recharging.

A first-aid kit and fire extinguisher should be positioned in an easily accessible area.

CAUTION! All metal parts on the battery are permanently live. Remove all metal objects and ensure that nothing can fall onto the battery before carrying out any operation on the battery. Always use insulated tools. Do not place anything on the batteries.

1. Installing charged batteries
Check that the terminal cables are correctly connected (polarity) and that the bolts are tightened: 10x1 Nm.
Start charging the battery (see point 3).

2. Use
Make sure the air vents do not become obstructed during use. Do not open or close the contacts during charging or discharging. Avoid deep discharges greater than 60% of nominal capacity. Deep discharges are not recommended. Do not recharge the battery until it has cooled down. The battery should be recharged as soon as possible following discharge.

3. Charging
Check and note down the voltage of each individual battery cell at the end of an equalize charge cycle.

Contact the assistance service in the event of significant variations with respect to the previous inspection. Thoroughly clean the battery (see point 7.1).
Check the condition of the insulation.

7. Cleaning
The battery is particularly important for good battery operation. All external parts and covers should therefore be dried and cleaned with care.

8. Storing batteries
Batteries should be stored in a well-ventilated area, protected against frost. Carry out periodical checks and recharge cycles, at least once a month. Never leave batteries discharged or with the voltage lower than 2.05 Vpc for more than 2 days. Always carry out a full charging cycle before any long periods of inactivity.

9. Malfunctions and faults
If you observe any malfunctions or faults, immediately in the event of battery malfunctions or faults. Take voltage and electrolyte density readings (see point 6.3) to help identify the fault.

THE WARRANTY IS INVALIDATED IN THE EVENT OF:
Failure to comply with these instructions for use and maintenance.
Use of non-original components.
The use of non-original components.
The use of non-original components.
The use of non-original components.
The use of non-original components.

6. Maintenance
6.1. **Daily**
Recharge the battery following a discharge cycle.

Batteries type open - VLA: check the electrolyte level only following a charge cycle. Top up with demineralised water only if necessary.

7. Cleaning
The battery is particularly important for good battery operation. All external parts and covers should therefore be dried and cleaned with care.

8. Storing batteries
Batteries should be stored in a well-ventilated area, protected against frost. Carry out periodical checks and recharge cycles, at least once a month. Never leave batteries discharged or with the voltage lower than 2.05 Vpc for more than 2 days. Always carry out a full charging cycle before any long periods of inactivity.

9. Malfunctions and faults
If you observe any malfunctions or faults, immediately in the event of battery malfunctions or faults. Take voltage and electrolyte density readings (see point 6.3) to help identify the fault.

LA GARANZIA DECADA NEL CASO DI:
Mancato rispetto delle presenti istruzioni d'uso e manutenzione.
Interventi effettuati da personale non autorizzato.
Iniego di componenti non originali.
Batterie VLA: aggiunta all'elettrolito di qualsiasi sostanza chimica ed eccezione di acqua demineralizzata.
Batterie VRLA: rimozione delle valvole (apertura della batteria).



Nennombenung:
DIN EN 50272-3 - SICHERHEITSAUFORDERUNGEN AN BATTERIEN UND BATTERIEANLAGEN.

Kenwerte der Batterie
1. Nennspannung (V): Siehe Typenschild
2. Nennkapazität C₂₀: Siehe Typenschild
3. Nennentladestrom: C/5
4. Entladeschlussspannung: 1,70 Vpc
5. Nenntemperatur: 30°C

DAR ELETROLITA' È UN LIQUIDO ALTAMENTE CORROSIVO (ACIDO SOLFONICO) IN GRADO DI CAUSARE GRAVI USTIONI SE ENTRA IN CONTATTO ACCIDENTALE CON GLI OCCHI O LA PELLE. LAVARE CON ABBONDANTE ACQUA CORRENTE E CONSULTARE UN MEDICO SE NECESSARIO. LE BATTERIE IN CARICA EMISSIONO UNA MISCELA ESPLOSIVA DI IDROGENO E OSSIGENO. RISCHIO DI ESPLOSIONI E DELIRAZIONI.

Bei Arbeiten an Batterien grundsätzlich eine Schutzbrille und Schutzkleidung tragen.

Nicht rauchen. Keine offenen Flammen verwenden. Kurzschlüsse und Funkenbildung in der Nähe der Batterie sowie im gesamten Ladebereich vermeiden.

Erst-Hilfe-Anleitung und Feuerlöscher an einem gut zugänglichen Ort aufbewahren.

ACHTUNG! Sämtliche Metallteile der Batterie stehen permanent unter Spannung. Vor Arbeiten an der Batterie alle Metallgegenstände entfernen und sicherstellen, dass keine Gegenstände auf die Batterie fallen können. Ausschließlich isolierte Werkzeuge verwenden. Keine Gegenstände auf Batterien ablegen.

1. Inbetriebnahme gefüllter Batterien
Den polaritären Anschluss der Endkabel und den Festzirkel der Schrauben von Stekern und Anschlussklemmen nachweisen: 10 ± 1 Nm.
Die Batterie laden (siehe Punkt 3).

2. Betrieb der Batterie
Bei Betrieb sicherstellen, dass die Lüftungsräume nicht verschlossen oder verdeckt werden. Die Kontakte nur in Stromlosen Zustand öffnen und schließen. Tiefentladungen von mehr als 60 % der Nennkapazität vermeiden. Tiefentladungen und Leertastungen den stromführenden Betrieb und die Lebensdauer der Batterie. Nach einer Entladephase muss die Batterie so rasch wie möglich wieder aufgeladen werden.

3. Laden der Batterie
Die Batterie nach jeder Arbeitsschicht wie folgt aufladen:
- Den Ladevorgang ausschließlich an einem dafür vorgesehenen Ort ausführen; siehe hierzu die Vorgaben der Norm DIN EN 50272-3.
- Die Batterie in gut belüfteten Räumen laden.
- Verschlüsse der einzelnen Batteriezellen jedoch geschlossen halten.
- Die Batterie ausschließlich mit der dafür vorgesehenen Batterieładeleistung laden.
- Die Batterie polrichtig an das Ladegerät anschließen und den Ladevorgang starten.

3.1. Ausgleicladung
Die Batterie muss mindestens zweimal pro Monat nach dem normalen Ladevorgang vorgenommen werden. Dies hilft, die Leistungsfähigkeit der Batterie zu erhalten und ist vor allem nach einem Betrieb mit Tiefentladungen oder unvollständigen Ladezyklen sehr sinnvoll.

4. Elektrolyt (offene Batterie - VLA)
Die Nennichte des Elektrolyten bei 30 °C beträgt 1,29 ± 0.01 kg/L.

5. Störungen und Defekte
Bei Störungen oder Defekten der Batterie umgehend den Kundendienst kontaktieren. Die aufgetrauten Spannung- und Dichtewerte aufzeichnen.
Spannungs- und Dichtewerte der Batterie, deren Spannung geringer als 2,05 Vpc ist, möglichst nicht länger als 2 Tage lagern. Vor längeren Standzeiten sind jeweils Vollladungen durchzuführen.

6. Wartung
6.1. **Tägliche Wartung**
Die Batterie nach einer Entladephase wieder aufladen.

Offene Batterie - VLA: Den Elektrolytstand stets kontrollieren.

7. Reinigung
Die Batterie ist für einen entwanderten Betrieb der Batterie äußerst wichtig. Daher den Deckel und sämtliche äußeren Komponenten der Batterie säubern und anschließend abbrocknen.

8. Lagerung von Batterien
Nicht verwendete Batterien staub- und frostfrei in einem geschlossenen und trockenen Raum lagern. Die erforderlichen Kontrollen und Nachladungen in monatlichen Abständen durchführen. Entladene Batterien, deren Spannung geringer als 2,05 Vpc ist, möglichst nicht länger als 2 Tage lagern. Vor längeren Standzeiten sind jeweils Vollladungen durchzuführen.

9. Malfunktionen und Defekte
Wenn Sie malfunktionen oder Defekte der Batterie beobachten, kontaktieren Sie sofort den Kundendienst. Infolge von malfunktionen oder Defekten der Batterie sind die folgenden Maßnahmen zu ergreifen:
- Spannung und Dichte des Elektrolyten messen und die Messwerte aufzeichnen.
- Die Temperatur der Batterie messen und die Messwerte aufzeichnen.

10. Garantiebedingungen
Die Garantie ist ungültig bei:
- Nichteinhaltung der Bedienungsanleitung.
- Eingriffen, die von nicht autorisiertem Personal vorgenommen werden.
- Verwendung von Nicht-Original-Ersatzteilen.
- Batterien des Typs VLA: Zugabe chemischer Stoffe zum Elektrolyten mit Ausnahme von demineralisiertem Wasser.
- Batterien des Typs VRLA: Entfernen der Ventile (Offnen der Batterie).

11. Sicherheit
11.1. **Tägliche Wartung**
Die Batterie nach einer Entladephase wieder aufladen.

Offene Batterie - VLA: Den Elektrolytstand stets kontrollieren.



EC DECLARATION OF CONFORMITY

(Annex IIA DIR. 2006/42/EC)

Robopac S.p.A.

Via Fabrizio da Montebello, 81 - 47892
Gualdicciolo Republic of San Marino

DECLARES THAT THE MACHINE

		
Robopac S.p.A. Via Fabrizio da Montebello, 81 47892 – Gualdicciolo Repubblica di San Marino http://www.aetnagroup.com/		
		
MODELLO MODEL		
MATRICOLA SERIAL NUMBER		
DATA DATE OF MANUF.		
ALIMENTAZIONE SUPPLY VOL.		[V]
FREQUENZA FREQUENCY		[HZ]
N° FASI PHASE		
ASSORBIMENTO ABSORPTION		[A]
POTENZA TOT. TOTAL POWER		[kW]
CONSUMO ARIA AIR CONSUMPTION		[nl/min]
PRESSIONE MAX MAX PRESSURE		[bar]
PESO WEIGHT		[kg]

IS IN CONFORMITY WITH DIRECTIVES

DIRECTIVE 2006/42/EC OF THE EUROPEAN PARLIAMENT AND OF THE COUNCIL of 17 May 2006 on machinery, and amending Directive 95/16/EC.

DIRECTIVE 2014/30/EU OF THE EUROPEAN PARLIAMENT AND OF THE COUNCIL of 26 February 2014 on the harmonisation of the laws of the Member States relating to electromagnetic compatibility.

Reference to harmonised standards and relevant annexes, in applicable points:

EN ISO 12100:2010, EN 60204-1:2006/A1:2009, EN 415-5:2010, EN 415-6:2013, EN 415-10:2014.

THE INDIVIDUAL AUTHORISED TO DRAFT THE TECHNICAL BOOKLET IS

Ing. Pierangelo Laghi - R&D Manager

c/o Aetna Group S.p.A.

S. P. Marecchia, 59

47826 Villa Verucchio

Rimini, Italy

Document date and place

Ing. Pierangelo Laghi - R&D Manager

San Marino,

Signature