



Operations Manual

Eagle T20CF Carton Erector



**READ ALL INSTRUCTIONS CONTAINED IN THIS
MANUAL PRIOR TO MACHINE INSTALLATION!**

Contents

	<i>page</i>
1. Safety & Warnings	3
2. Specifications	4
3. Setup and Installation	5
3.1 Transportation	5
3.2 Tape Head Installation	5
3.3 Power Supply	5
4. Operation	6
4.1 Standard Operation	6
4.2 Case Erector	6
4.3 Carton Size Adjustment	7
4.4 Feeding Adhesive Tape	8
4.5 Control Panel Operation	8
4.6 LCD Display Operation	9
5. Maintenance & Troubleshooting	10
5.1 Maintenance	10
5.2 Troubleshooting	10
6. Illustrations & Parts List	12
6.1 Replacement Parts	12
6.2 Carton Storage Shelf	13
6.3 Carton Storage Table	14
6.4 Carton Pre-Storage Table Lifting Body	16
6.5 Back Cover Carton Push & Fold	18
6.6 Machine Frame	20
6.7 Front Cover Folder	22
6.8 Conveyer Belt	23
6.9 Vacuum-Assisted Carton Placer	25
6.10 Blocking Pin & Press Plate	27
6.11 Left & Right Cover Folder	29
6.12 Carton Sealer – Front Roller	31
6.13 Carton Sealer – Rear Roller	33
6.14 Carton Sealer – Roller	34
6.15 Guide Pulley	35
6.16 Tape Knife	36
6.17 Tape Dispenser	37
6.18 Tape Wheel	38
6.19 Tape Press	39
6.20 Tape Guide	40
6.21 Electrical Diagrams	41

1. Safety and Warnings



WHILE OPERATING THE MACHINE, OPERATORS MUST REFRAIN FROM WEARING CLOTHING OR ACCESSORIES THAT MAY GET CAUGHT IN THE MOVING PARTS OF THE MACHINE (WATCHES, RINGS, BRACELETS, TIES, LOOSE CLOTHING, ETC...)

This manual covers safety precautions, parameters, machine operation, maintenance, and troubleshooting information.

Prior to setting up the machine

1. Verify the model number matches the model number addressed in this manual.
2. Verify that no parts of the machine have been removed or are missing.
3. Remove all packaging or shipping materials used during transport or storage of the machine.
4. Check for any damage that may have occurred during shipping or transport.

Prior to operating the Eagle T20CF, verify

- Verify power supply voltage matches the requirements of the machine.
- Protective shielding and covers are properly installed
- Machine is on stable ground and casters are in the locked position.

The Eagle T20CF is designed to automatically shut down if the control panel is opened while the machine is in operation.

2. Specifications

Power Requirement	220VAC, 50/60Hz (Single Phase)
Air Supply	85psi (6Kgf/cm ²)
Tape Width	2-3in (48-72mm)
Working Speed	0-12 cases per minute
Carton Length	11-20.5in
Carton Width	7-11in
Carton Height	11-24in
Machine Length	80.7in
Machine Width	86.6in
Machine Height	53in
Weight	882lbs
Operational Environment	32-104°F (0-40°C) @ ≤ 98% Humidity
Machine Noise Levels	≤ 75db

3. Machine Setup and Installation



TAKE CARE TO AVOID DAMAGE TO THE MOTOR AND ASSEMBLY WHILE LIFTING OR TRANSPORTING THE MACHINE!

3.1 Transportation

Use a fork lift or tow motor to remove the machine from its shipping container or pallet.

3.2 Tape Head Installation

Remove the front supporting shaft. Rest the rear of the tape head on the rear supporting shaft. Place the front supporting shaft on the angled notches in the front of the tape head and lower the tape head down guiding the pin into the notches in the frame.

Check tape cutter position and adjust as needed.

3.3 Connect Power Supply

Connect the machine to the power supply.

Note: Prior to connecting the machine to the power supply, verify that the power switch is set to the 'OFF' position and that the work area is clean and clear of any items.

4. Operation

4.1 Standard Operation

Prior to operating the machine, please confirm that

1. The proper voltage is being supplied to the motor
2. All fasteners and protective covers are securely in place
3. All electronic components are dry

Machine Operation

1. Plug the machine into the power source
 - a. DO NOT hard wire the machine to the power source
2. Turn on air supply.
3. Feed cartons to be erected into storage tray

4.2 Case Erection

1. Adjust the machine for the size of the cartons to be erected.
2. Place the cartons on the carton storage shelf.
3. Machine will place carton, fold front and rear lower flaps, fold left and right lower flaps, and seal bottom of the carton.

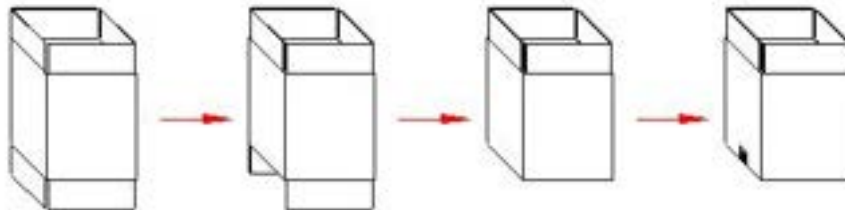

4. Operation

4.3 Carton Size Adjustment

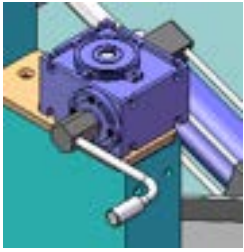

Width/2 Adjustment

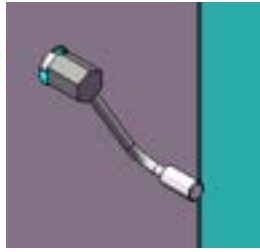

Width Adjustment

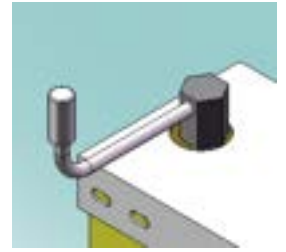

Press Plate Height Adjustment

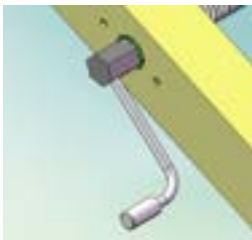
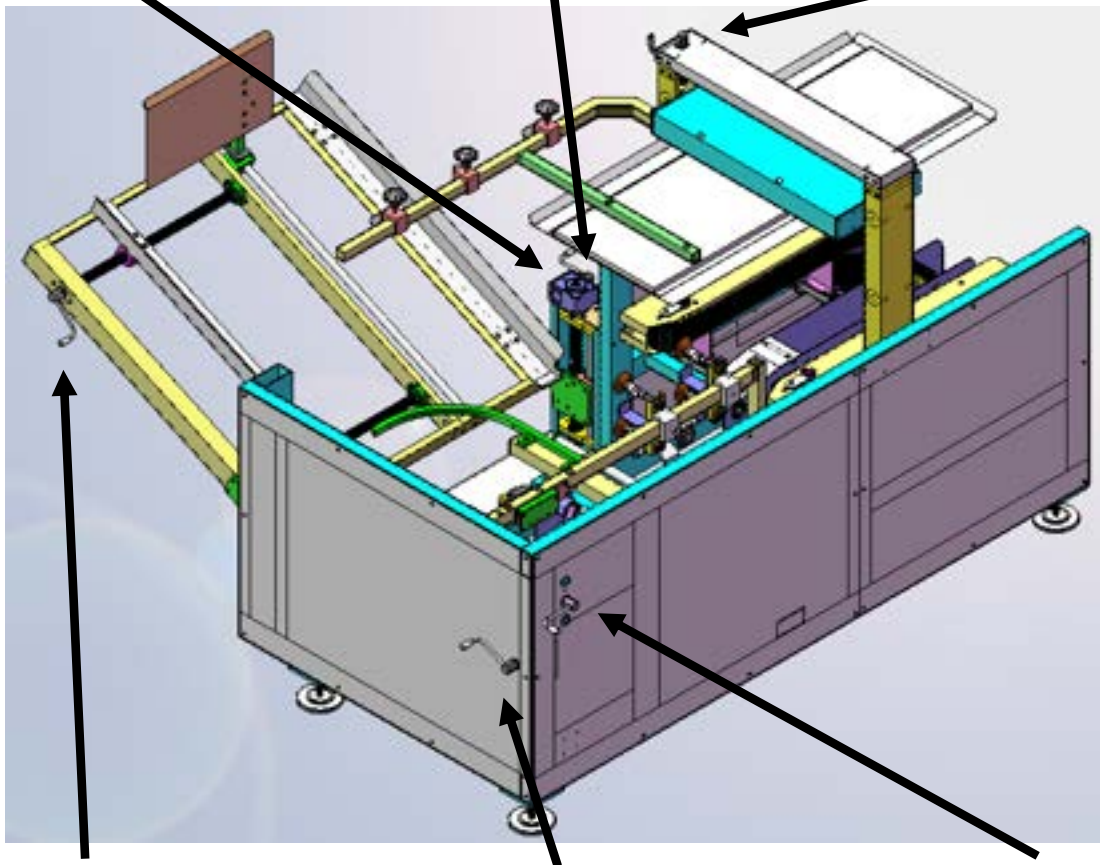

Length + Width Adjustment



Length Adjustment



Width Adjustment

4. Operation

4.4 Feeding the Adhesive Tape

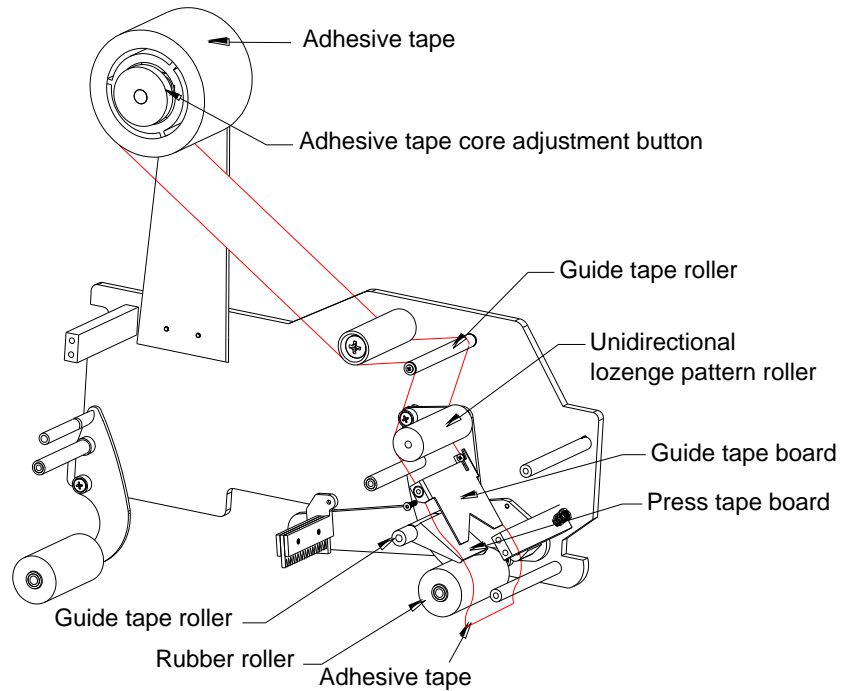

4.5 Control Panel Operation

Before operating the machine, the operator should review the features and functions of every switch to ensure the correct and safe operation of the machine.

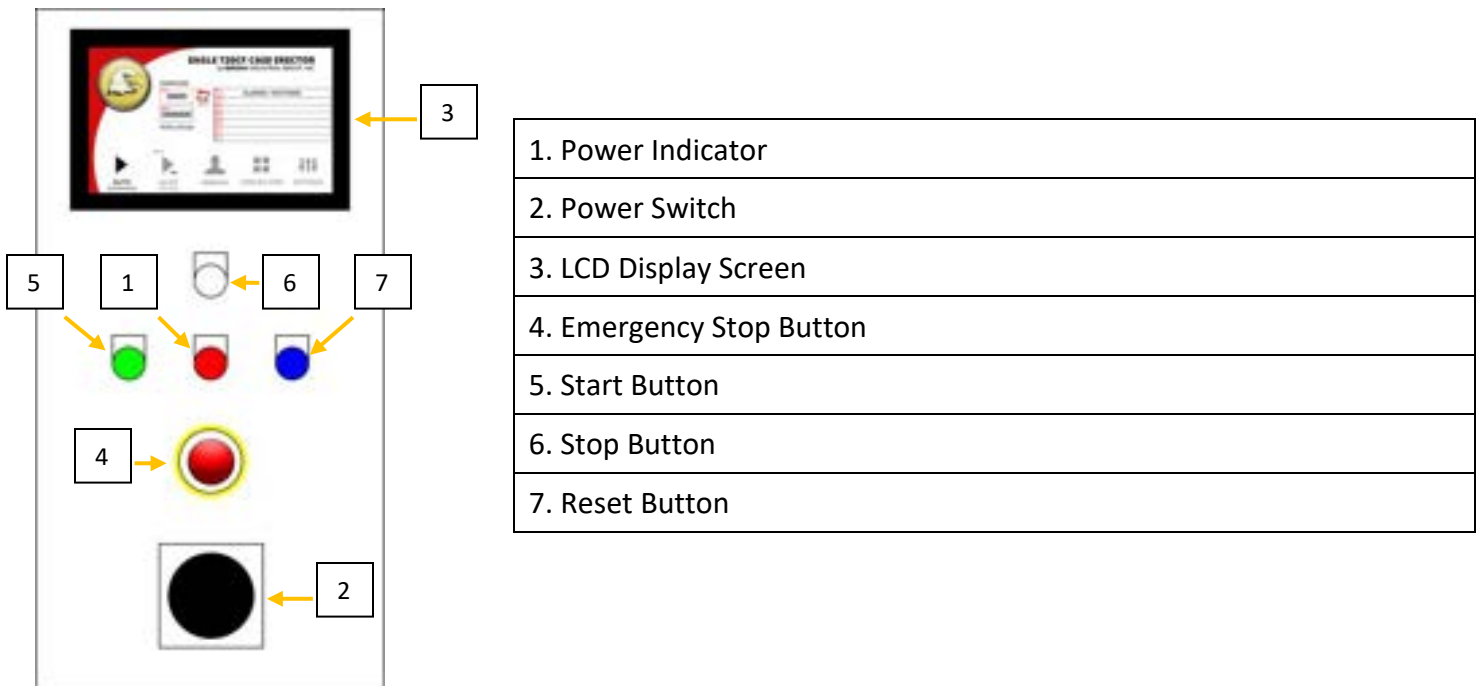

4.6 LCD Display Operation



Start Screen

Once the machine has fully powered up, this screen will be displayed. Continue by pressing the button labeled "CONTINUE".



Automatic Mode

There are two automatic operation modes. In the first mode, the machine will run continuously until carton stock has been exhausted. The second mode, called "Set Qty", will erect a preset number of cartons and will stop the machine once the preset number of cartons have been completed.



Manual Mode

While in manual mode, the machine will allow for operation in which it will pause after each step and wait for input from the operator before continuing.

4.6 LCD Display Operation



Step-by-Step

This screen permits the user to run the machine one step at a time. The first step is to load the carton into the folding position. This is accomplished by pressing the green icon labeled "LOAD BOX INTO FOLDING POSITION". Then press "PROCEED TO NEXT STEP" to move through each step until the completed carton is driven out of the machine.



Settings

This is the screen where fault timers and action timers can be modified.

5. Maintenance & Troubleshooting

5.1 Maintenance



TURN POWER SWITCH TO THE OFF POSITION AND DISCONNECT FROM POWER SUPPLY PRIOR TO PERFORMING ANY MAINTENANCE OR REPAIRS TO THE MACHINE

Regular maintenance will prolong machine life and lower the chance of malfunctions.

1. Check that all connections are tight.
2. Ensure that all screws, bolts and other mechanical connections are tight.
3. Lubricate moving parts.
 - a. Chain (Wheel)
 - b. Screw Rod
 - c. Guide Rail (Slide Block)
 - d. Guide Rod
4. Clean tape cutting blade.

5.2 Troubleshooting

Case does not seal well	Adhesive tape is not centered on the box.	Adjust the tape alignment.
Adhesive tape does not cut properly	The blade is too high, will also case scrape marks on the carton	Lower cutting blade
	The blade is too low	Raise cutting blade
	Cutter force is too low	Adjust the tension of the cutter force spring on the blade shelf.
Adhesive tape does not adhere to the carton	Unidirectional rubber wheel is broken	Replace
	The head of back adhesive tape is wiping unevenly.	Adjust the speed of the press/wipe belt cylinder.
	Adhesive tape is wrinkled.	Adjust the force of extension spring of front rubber wheel.
Carton does not feed properly	The spacing of the catch pin is too narrow.	Adjust catch spin spacing.
	Irregularly shaped carton	-
	Suction feed system malfunction	Check for defects or damage to the suction disks. Replace as needed.

5. Maintenance & Troubleshooting

5.2 Troubleshooting (continued)

Carton does not feed properly while erecting	The base of the carton is not level to the machine.	Adjust carton alignment
Suction and placement of carton error	Air pressure is out of range	Adjust supply air pressure to match machine requirements
	Suction disk malfunction	Check for proper alignment, cracks or deformities on the suction disk.
	Suction fixture misaligned	Verify and adjust as necessary.

6. Machine Parts & Illustrations

6.1 Replacement Parts

	Description	Part Number	Qty
1	Case-Sealing Blade		
2	Machine Core Extension Spring		
3	Chain		
4	Electromagnetic Valve		
5	Travel Switch (photoelectric, prox)		
6	Fuse		
7	Magnetic Inductive Switch		
8	Vacuum Suction Disk		
9	Motor		
10	Belt		

6. Machine Parts & Illustrations

6.2 Carton Storage Shelf

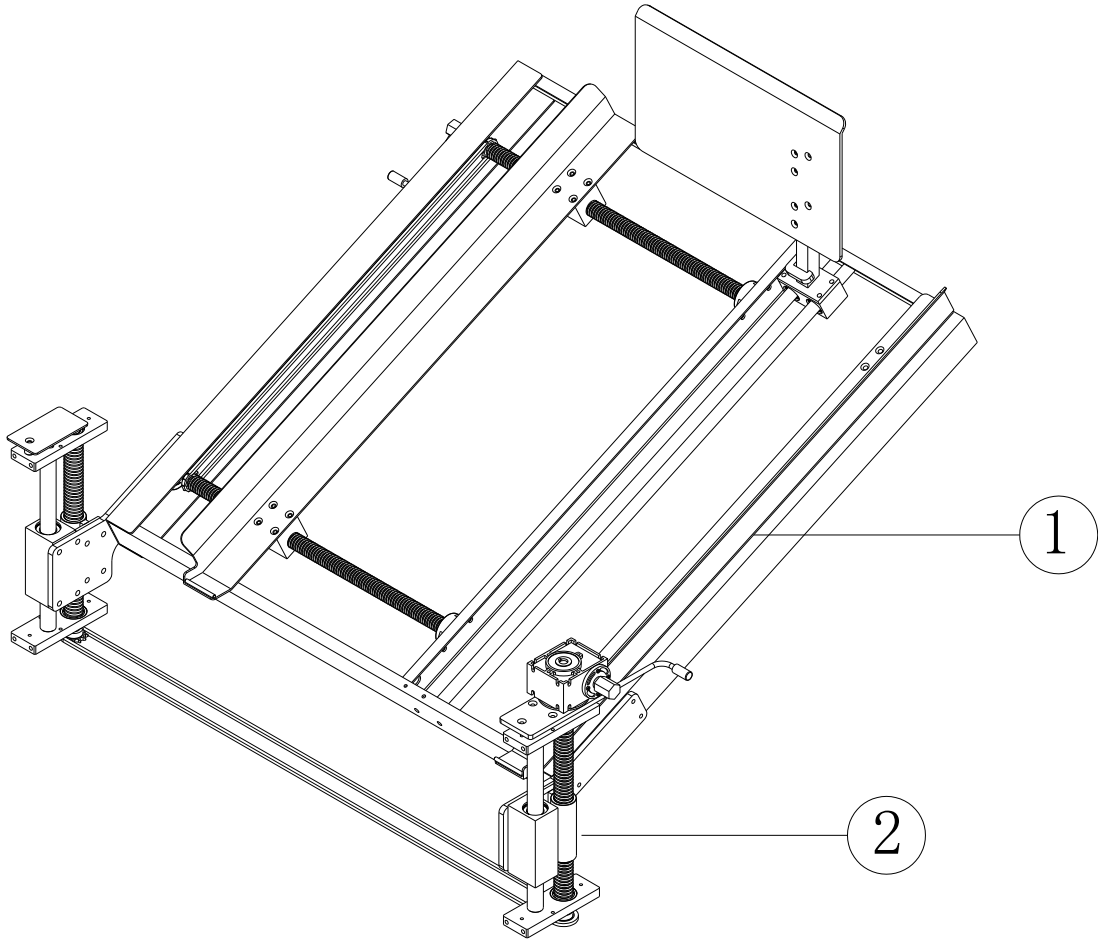

	Description	Part Number	Qty
1	Carton Storage Table		1
2	Carton Storage Table Lifting Body		1

6. Machine Parts & Illustrations

6.3 Carton Storage Table Assembly

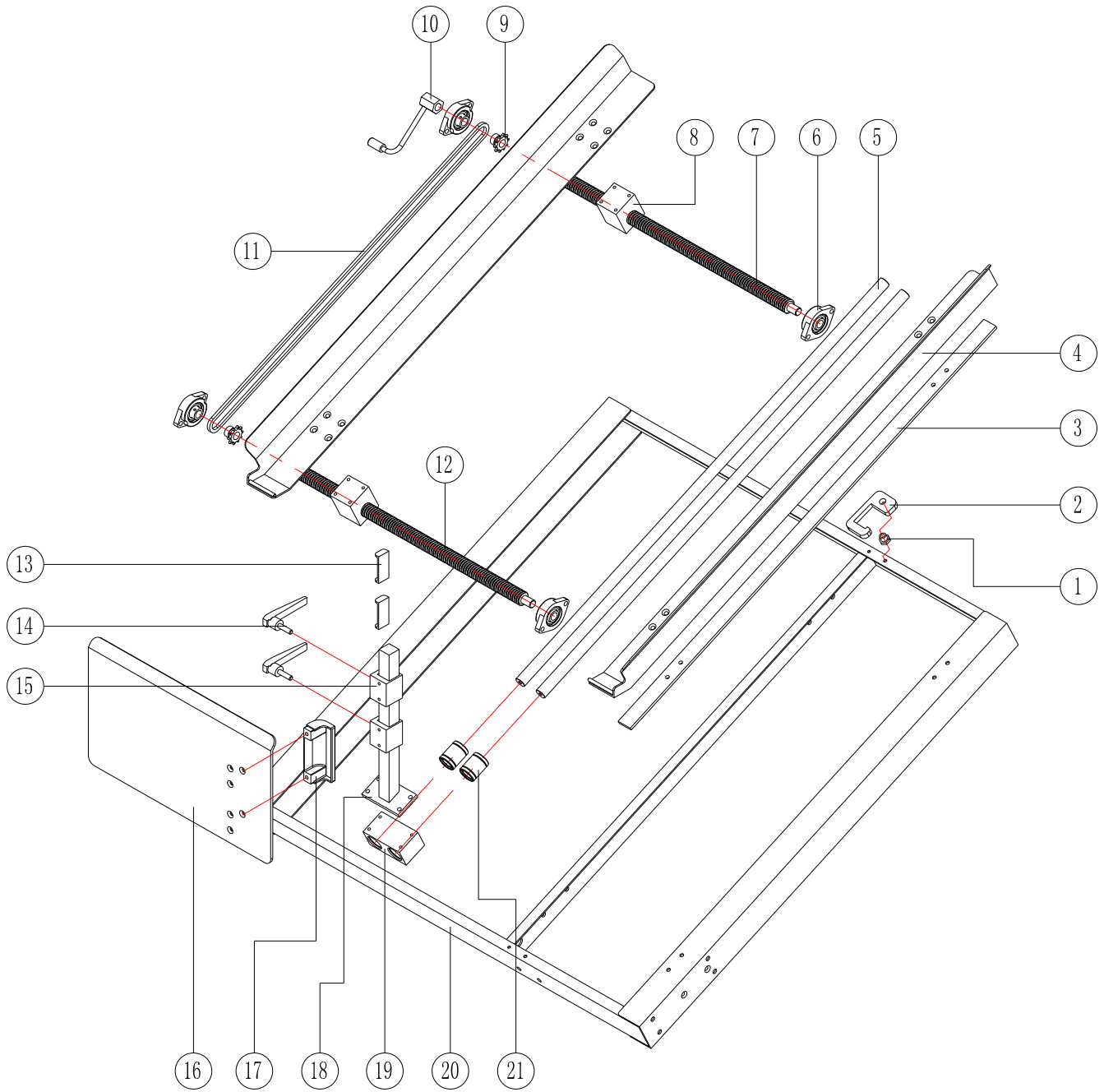

6. Machine Parts & Illustrations

6.3 Carton Storage Table Assembly (continued)

	Description	Part Number	Qty
1	Drag Hook Base	CF-20TX-159	1
2	Drag Hook	CF-20TX-60	1
3	Guide Carton Board Filler Strip	CF-20TX-57	1
4	Guide Carton Board	CF-20TX-56	2
5	Send Carton Guide Rod	CF-20TX-58	2
6	Baring Base	SBLF 202	4
7	Work Table Screw Rod I	CF-20TX-62	1
8	Screw Nut	CF-20T-H-01	2
9	Chain Wheel	FJ-MA-60	2
10	Handle	-	1
11	Chain	06B	
12	Work Table Screw Rod	CF-20TX-61	1
13	Fixing Block Backing Board	CF-20TX-51	2
14	Hand Wheel	-	2
15	Send Carton Board Fixing	CF-20TX-50	2
16	Push Carton Board	CF-20TX-63	1
17	Handle	-	1
18	Send Carton Stand Rod Assembly	CF-20TX-53	1
19	Send Carton Linear Base	CF-20TX-48	1
20	Worktable	CF-20TX-68	1
21	Linear Bearing	LM20UU	2

6. Machine Parts & Illustrations

6.4 Carton Pre-Storage Table Lifting Body Assembly

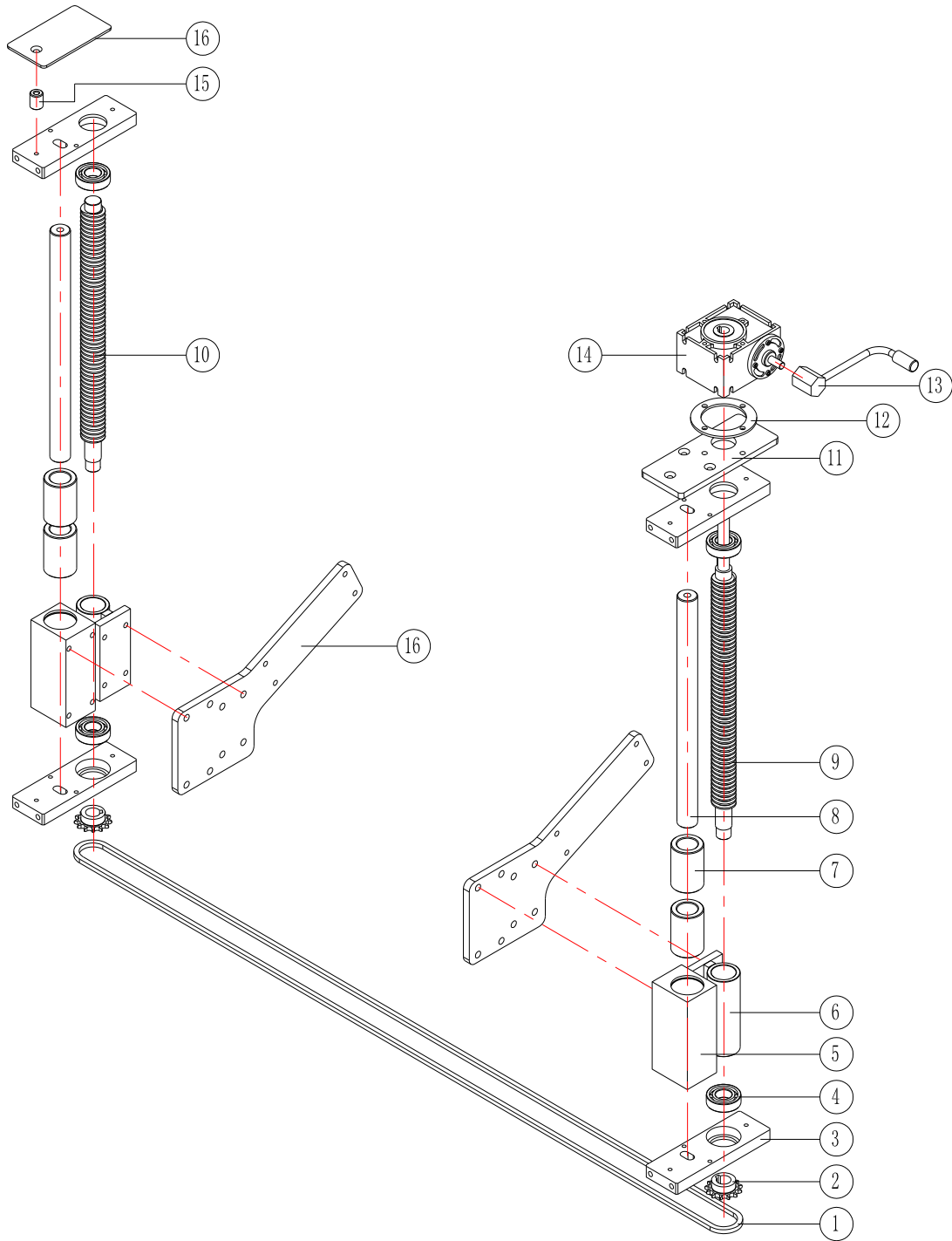

6. Machine Parts & Illustrations

6.4 Carton Pre-Storage Table Lifting Body Assembly (continued)

	Description	Part Number	Qty
1	Chain	06B	1
2	Lifting Screw Rod Chain Wheel	FJ-1A-130	2
3	Lifting Supporting Board	CF-20TX-69	4
4	Bearing	6004	4
5	Linear Slide Base I	CF-01-04-047.1	2
6	Lifting Screw Nut Base	FJ-1A-150	2
7	Sliding Bush	CF-20TX-178	4
8	Work Table Supporting Rod	CF-20TX-84	2
9	Lifting Screw Rod	CF-20TX-85	1
10	Lifting Screw Rod I	CF-20TX-86	1
11	Speed Reducer Base Plate	CF-20TX-177	1
12	Speed Reducer Pad Ring	CF-20TX-176	1
13	Handle		1
14	Speed Reducer	NRW 030	1
15	Work Table Base Plate	CF-20TX-64	2

6. Machine Parts & Illustrations

6.5 Back Cover Carton Fold & Push Device

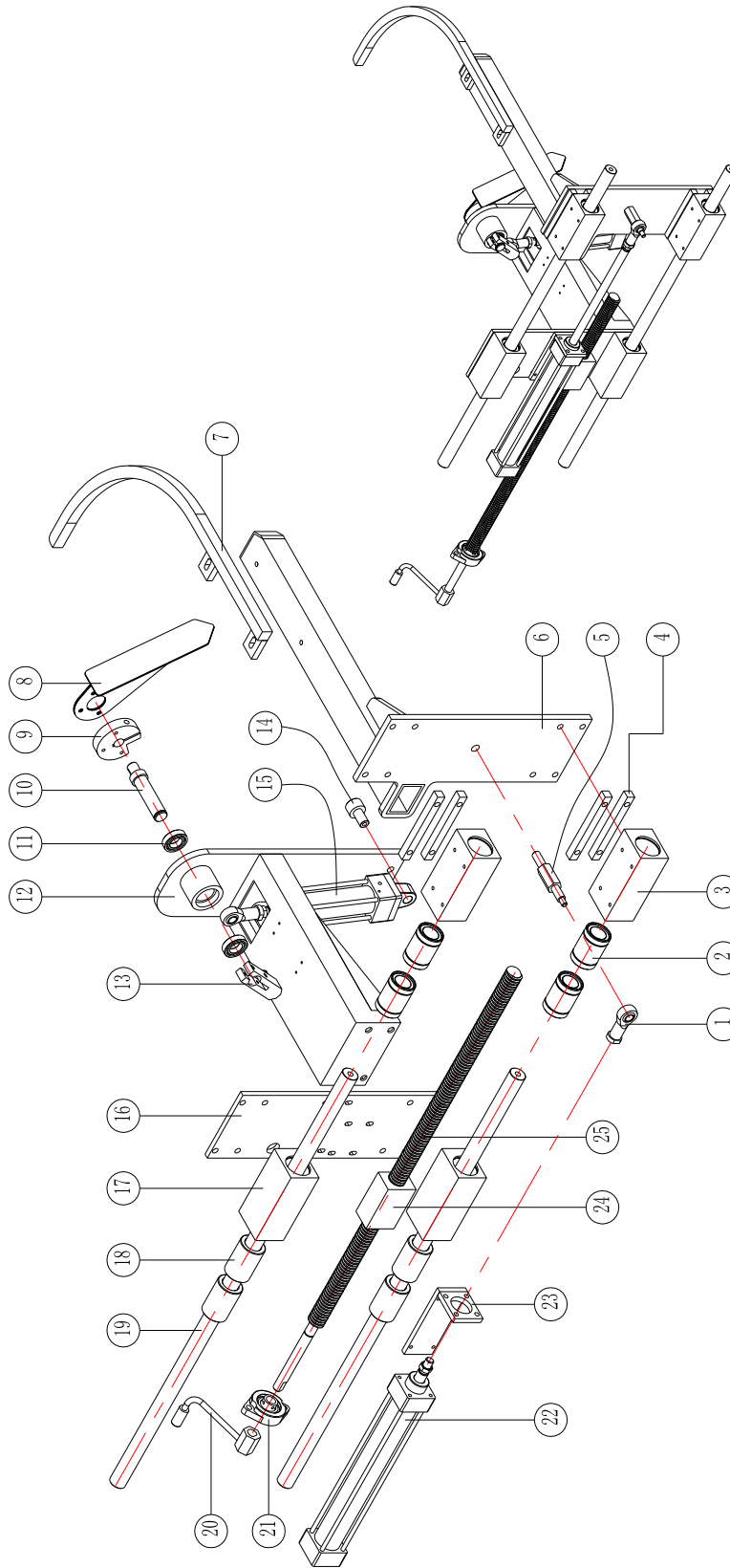

6. Machine Parts & Illustrations

6.5 Back Cover Carton Fold & Push Device (continued)

	Description	Part Number	Qty
1	Pearl Eye Joint	SC40	2
2	Linear Bearing	LM25UU	4
3	Linear Sliding Base	CF-20TX-38	2
4	Linear Filling Strip	CF-20TX-21	4
5	Push Carton Cylinder Front Shaft	CF-20TX-28	1
6	Push Carton Rod Combination	CF-20TX-33	1
7	Molding Bent Rod	CF-20TX-36	1
8	Folding Pendulum	CF-20T-G-14	1
9	Folding Cramp Arm	CF-01-04-21.1	1
10	Pendulum Shaft	CF-01-04-25.4	1
11	Bearing	61904	2
12	Back Folding Cover Base	CF-20TX-27	1
13	Folding Front & Back Swing Arm	CF-20T-09	1
14	Folding Back Cylinder End Shaft	CF-01-04-198.1	1
15	Cylinder	SC40x80-S	1
16	Length Base Plate	CF-20TX-46	1
17	Linear Sliding Base II	CF-01-04-047.3	2
18	Slide Bushing	CF-20TX-178	4
19	Length Guide Rod	CF-20TX-47	2
20	Handle		1
21	Bearing Base	SBLF202	1
22	Cylinder	SC40x250-S	1
23	Push Carton Cylinder Base	CF-20TX-24	1
24	Length Screw Nut	CF-20TX-45	1
25	Length Screw Rod	CF-20TX-81	1

6. Machine Parts & Illustrations

6.6 Machine Frame

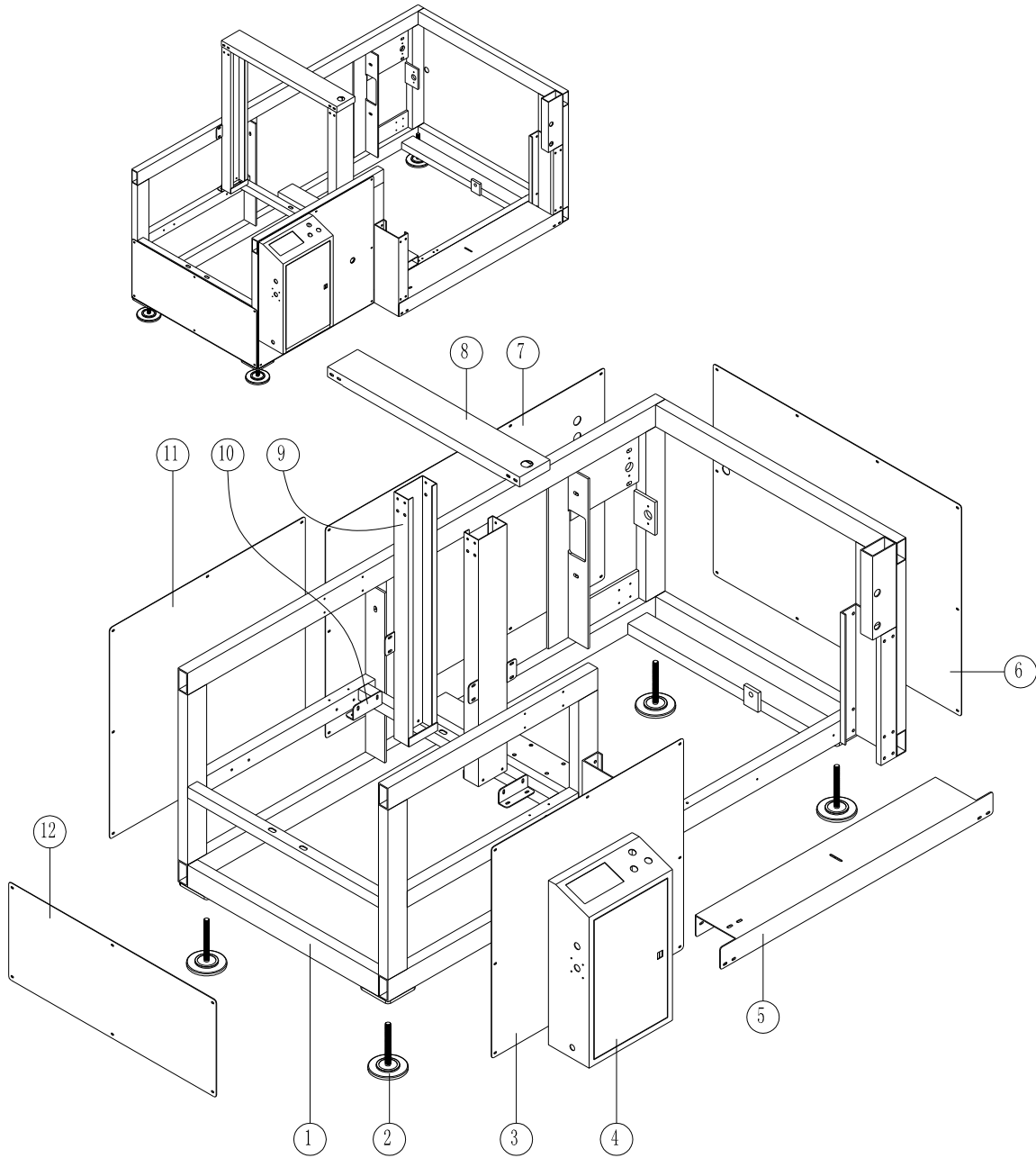

6. Machine Parts & Illustrations

6.6 Machine Frame

	Description	Part Number	Qty
1	Machine Frame	CF-20TX-174	1
2	Foot Cup	M16	4
3	Side Sealing Plate	CF-20TX-180	1
4	Electrical Box	CF-20T-2-3	1
5	Chain Lid Plate	CF-20TX-96	1
6	End Sealing Plate I	CF-20TX-181	1
7	End Sealing Plate II	CF-20TX-183	1
8	Top Beam	CF-20TX-118	1
9	Stand Rod Combination	CF-20TX-123	1
10	Stand Rod L Plate	CF-20TX-119	
11	Side Sealing Plate I	CF-20TX-182	1
12	End Sealing Plate	CF-20TX-179	1

6. Machine Parts & Illustrations

6.7 Front Cover-Folding Assembly

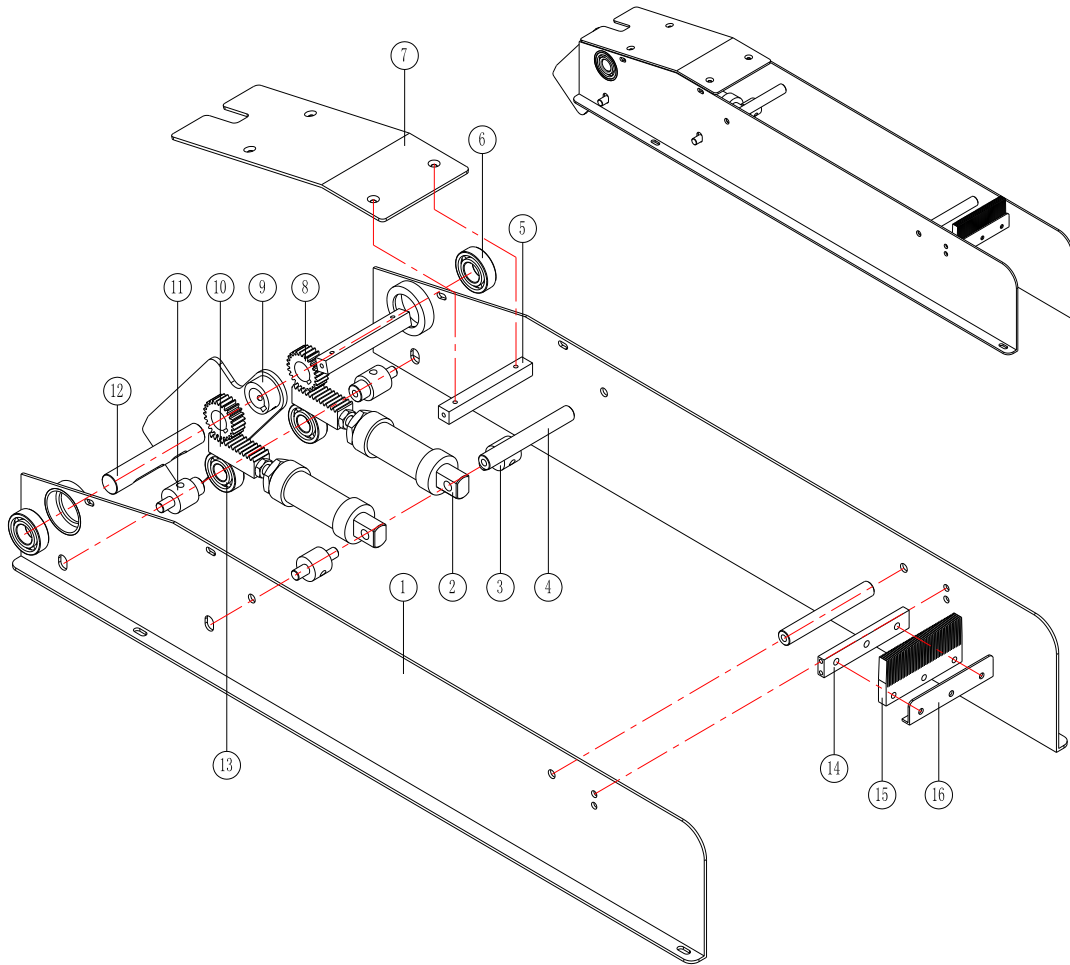

	Description	Part Number	Qty
1	Machine Core Support Plate	CF-20TX-15	2
2	Cylinder	MAL32x30-CA	2
3	Folding front Cylinder Back Shaft	CF-20TX-4	2
4	Connecting Rod	CF-01-04-190	2
5	Transition Plate Fixing Bar	CF-20TX-13	2
6	Bearing	6004	2
7	Transition Plate	CF-20TX-14	1
8	Folding Front Gear	CF-20TX-3	2
9	Folding Front Plate Combination	CF-20TX-7	1
10	Folding Front Rack	CF-20TX-2	2
11	Folding Front Rack Bearing Shaft	CF-20TX-5	2
12	Folding Front Turning Shaft	CF-20TX-8	1
13	Bearing	6203	2

14	Brush Shelf	CF-20T-201	1
15	Hair Brush		1
16	Press Plate	FJ-2A-134	1

6. Machine Parts & Illustrations

6.8 Conveyer Belt Assembly

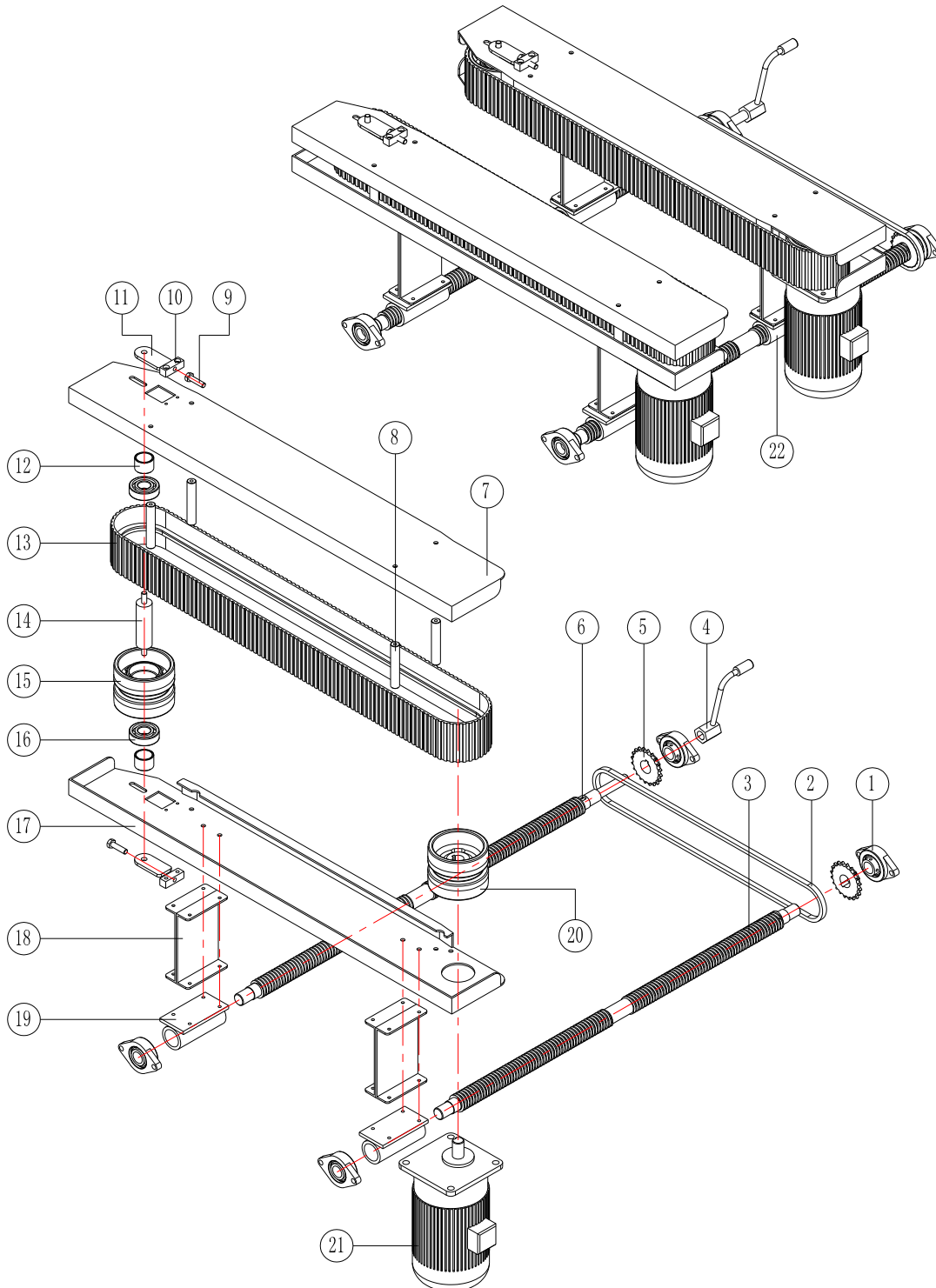

6. Machine Parts & Illustrations

6.8 Conveyor Belt Assembly (continued)

	Description	Part Number	Qty
1	Bearing Base	SBLF 204	4
2	Chain	06B	1
3	Left & Right Screw Rod I	FJ-1A-55	1
4	Handle		1
5	Drive Chain Wheel	CF-01-05-3.1	2
6	Left & Right Screw Rod II	CF-20TX-12	1
7	Side Input Top Plate	CF-20TX-11	2
8	Cover Plate Supporting Post	CF-18T-159	8
9	Screw Bolt	M8	4
10	Top Block	FJ-18T-1	4
11	Drive Wheel Press Plate	FJ-18T-2	4
12	Drive Wheel Spacer Bushing	FJ-18T-161	4
13	Side Input Guide Bar Belt	1690x73x5	2
14	Drive Wheel Shaft	FJ-18T-160	2
15	Drive Wheel	25-636-1	2
16	Bearing	6005	4
17	Side Input Lower Plate	CF-20TX-10	2
18	Screw Nut Upper Rack	CF-20TX-9	8
19	Left Screw Nut Base	FJ-1A-95	2
20	Drive Wheel	25-002-1	2
21	Motor	CF200 15AZ	2
22	Right Screw Nut Base	FJ-1A-94	2

6. Machine Parts & Illustrations

6.9 Vacuum-Assisted Carton Placer Assembly

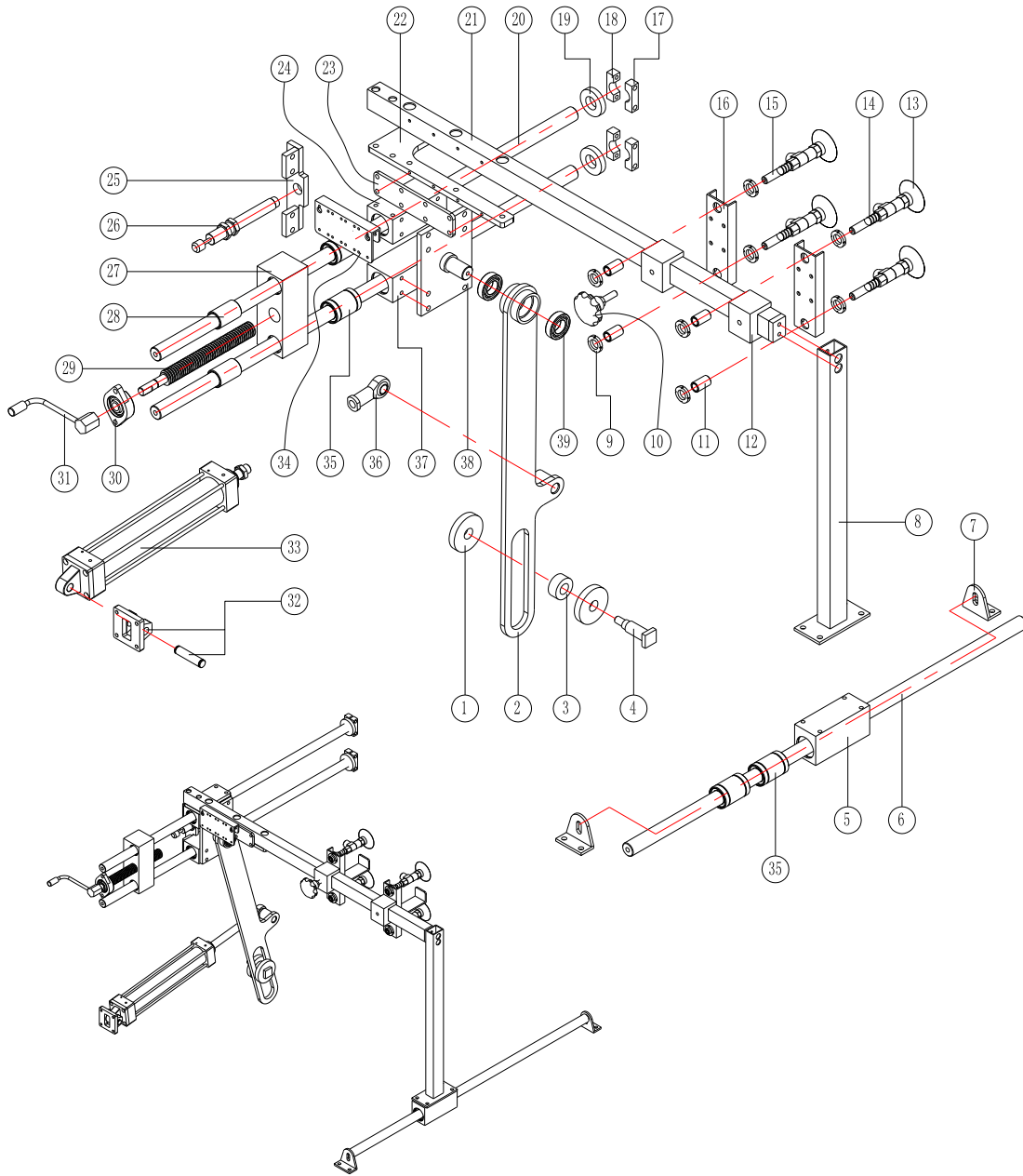

6. Machine Parts & Illustrations

6.9 Vacuum-Assisted Carton Placer Assembly (continued)

	Description	Part Number	Qty
1	Large Pulley	CF-20TX-127	2
2	Connecting Rod Assembly	CF-20TX-132	1
3	Small Pulley	CF-20TX-128	1
4	Pulley Shaft	CF-20TX-133	1
5	Linear Sliding Base I	CF-01-04-047.1	1
6	Width Guide Rod	CF-20TX-94	1
7	Guide Rod L Plate	CF-20TX-93	2
8	Vacuum Disc Upright Sliding Rod	CF-20TX-92	1
9	Vacuum Disc Cap	CF-20TX-18	8
10	Hand Wheel		1
11	Vacuum Disc Sliding Bush	CF-20TX-17	4
12	Sliding Base	CF-01-04-039	2
13	Vacuum Disc	ESS-80-GT-G1/4	4
14	Spring		4
15	Sliding Rod	CF-20TX-20	4
16	Vacuum Disc Installation Plate	CF-20TX-37	4
17	Width Limit Clamp Block	CF-20TX-147	2
18	Width Limit Clamp Block I	CF-20TX-148	2
19	Width Cushion Ring	CF-20TX-149	2
20	Width Guide Rod I	CF-20TX-95	2
21	Vacuum Disc Level Sliding Rod	CF-20TX-89	1
22	Sliding Rod Base Plate	CF-20TX-79	1
23	Sliding Rod Connecting Plate	CF-20TX-199	1
24	Width Linear Base	CF-20TX-73	1
25	Cushion Installation Base	CF-20TX-77	1
26	Oil Pressure Bumper	AC-2020-2	1
27	Width Limit Sliding Base	CF-20TX-70	2
28	Width Sliding Bushing	CF-20TX-71	2
29	Width Screw Rod	CF-20TX-80	1
30	Bearing	SBLF 202	1
31	Handle		1
32	Cylinder Accessory	SC50-CB	1
33	Cylinder	SC50x80-S	1
34	Vacuum Installation Plate	CF-01-04-146	1
35	Linear Bearing	LM25UU	6
36	Cylinder Pear Eye Joint	SC50	1
37	Width Linear Base	CF-20TX-74	1
38	Connecting Rod Shaft Base	CF-20TX-126	1
39	Bearing	6005	2

6. Machine Parts & Illustrations

6.10 Blocking Pin & Press Plate Assembly

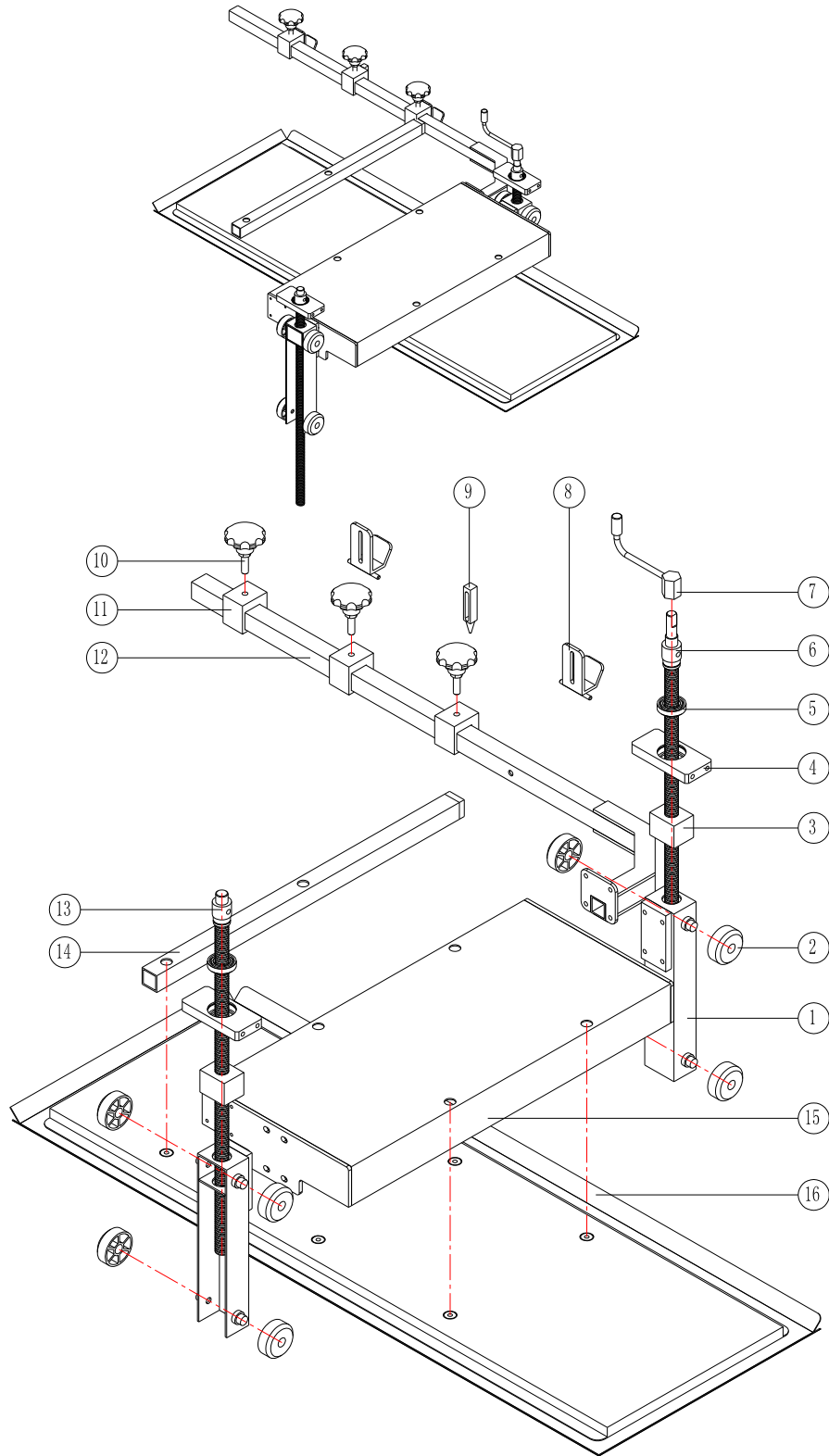

6. Machine Parts & Illustrations

6.10 Blocking Pin & Press Plate Assembly (continued)

	Description	Part Number	Qty
1	Lifting Body	FJ-1A-30	2
2	Upright Pose Roller Wheel	FJ-1A-105	8
3	Screw Nut	FJ-1A-106	2
4	Supporting Plate	FJ-1A-69	2
5	Bearing	61905	2
6	Lifting Screw Rod	FJ-1A-71	1
7	Handle		1
8	Carton Rack Upper Block	CF-20TX-100	2
9	Blocking Pin	CF-20TX-98	1
10	Hand Wheel		3
11	Carton Sliding Base Block	CF-20TX-97	3
12	Pin Rack Block	CF-20TX-198	1
13	Pin Rack Supporting Pipe Block	CF-20TX-193	1
14	Lifting Screw Rod	FJ-1A-70	1
15	Leveling Arm Assembly	CF-20TX-186	1
16	Press Plate	CF-20TX-189	1

6. Machine Parts & Illustrations

6.11 Left & Right Cover Folder Assembly

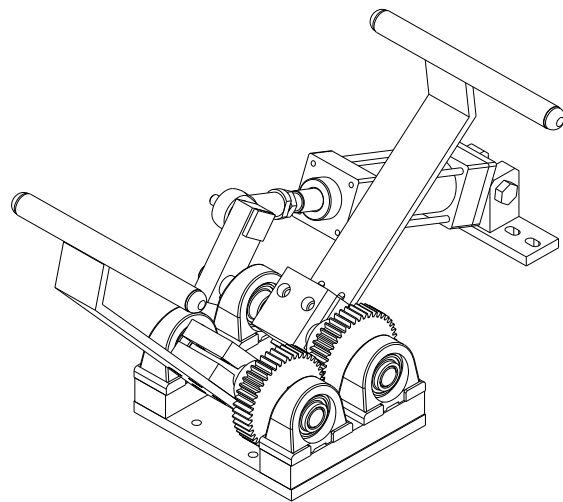
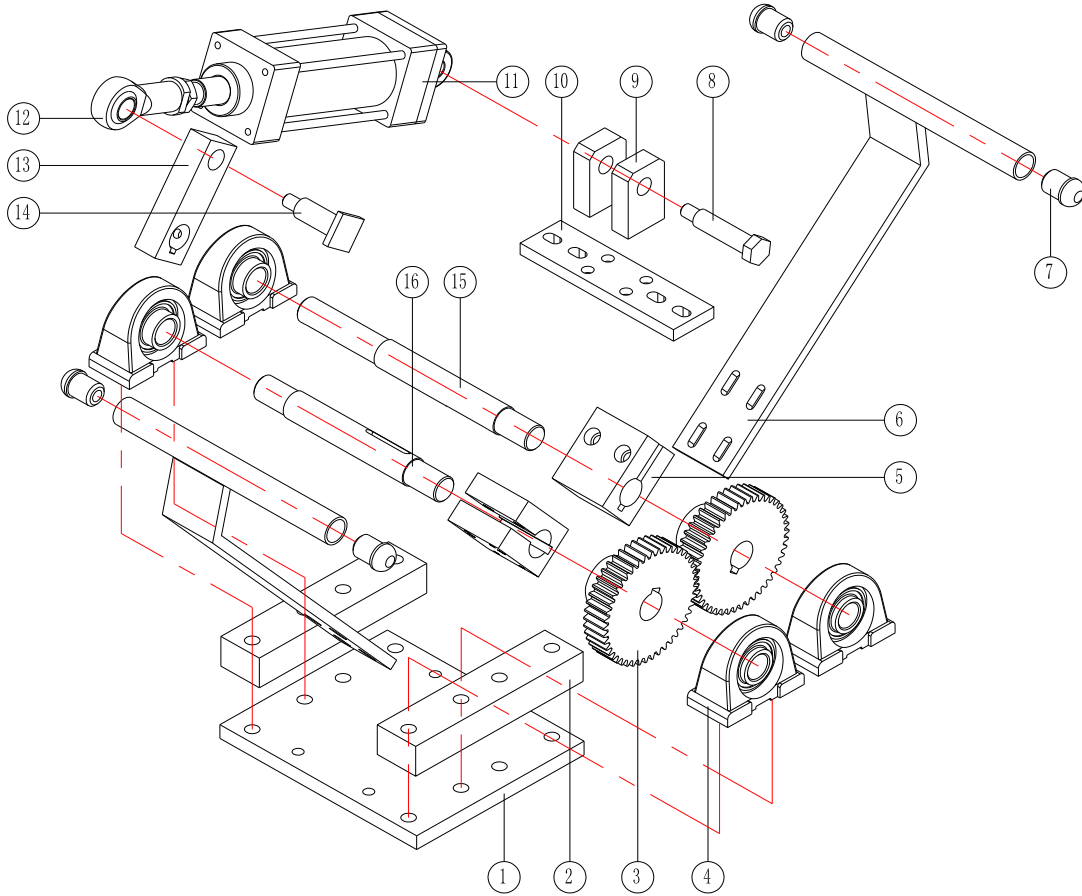

6. Machine Parts & Illustrations

6.11 Left & Right Cover Folder Assembly (continued)

	Description	Part Number	Qty
1	Left / Right Folding Base	CF-20TX-150	1
2	Bearing Base Padding Block	CF-20TX-136	2
3	Conveyor Gear	CF-20TX-135	2
4	Bearing Base	UCPA 204	4
5	Clamping Block	CF-20TX-134	2
6	Left / Right Folding Rod	CF-20TX-144	2
7	Folding Rod Closure Head	CF-20TX-141	4
8	Folding Rod Cylinder Back Shaft	CF-20TX-151	1
9	Back Base Block	CF-20TX-145	2
10	Back Base Plate	Cf-20TX-146	1
11	Cylinder	SC50x80-s	1
12	Cylinder Pearl Eye Joint	SC50	1
13	Swing Block	CF-20TX-137	1
14	Folding Rod Cylinder Front Shaft	CF-20TX-138	1
15	Folding Rod Moving Shaft	CF-20TX-140	1
16	Folding Rod Shaft	CF-20TX-139	1

6. Machine Parts & Illustrations

6.12 Carton Sealer - Front Roller Assembly

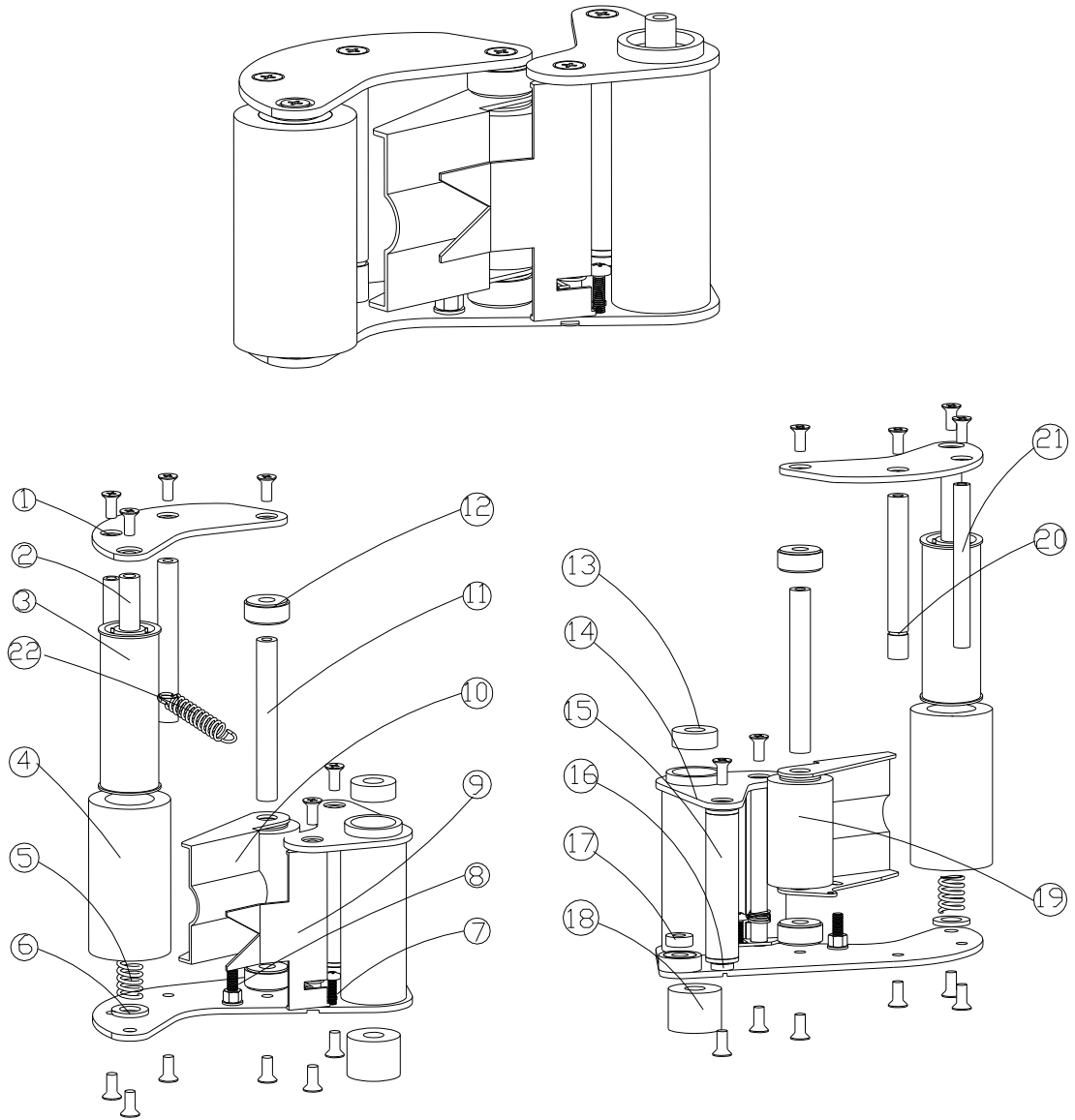

6. Machine Parts & Illustrations

6.12 Carton Sealer - Front Roller Assembly (continued)

	Description	Part Number	Qty
1	Bracket	FJ-01-09	1
2	Front & Back Roller Shaft	FJ-00-10	1
3	One-Way Roller Shaft	FJ-E-38-01	1
4	Front Rubber Roller Wheel	FJ-E-41-01	1
5	Front Roller Wheel Press Spring	FJ-H-02	1
6	Front Roller Wheel Washer	FJ-04-06	1
7	Cross Flat Trench Screw	M4x12	1
8	Cross Flat Head Screw	M5x15	1
9	Press Tape Board Assembly		1
10	Hold-Down Unit		1
11	Front Claw Fulcrum	FJ-00-09	1
12	Guide Tape Board Spacer	FJ-02-02	2
13	Bearing	6900 (1080900)	1
14	Front Claw	FJ-50-00	1
15	Guide Tape Wheel Assembly		1
16	Tape Wheel Knurling Spacer Bushing	FJ-02-11	1
17	Bearing	688Z (208088)	1
18	Bearing	HK2020	1
19	Guide Tape Board Roller Wheel	FJ-02-10	1
20	Tension Spring Shaft	FJ-00-11	1
21	Front Claw Fulcrum	FJ-00-09	1
22	Guide Tape Board Tension Spring	FJ-H-00	1

6. Machine Parts & Illustrations

6.13 Carton Sealer - Rear Roller Assembly

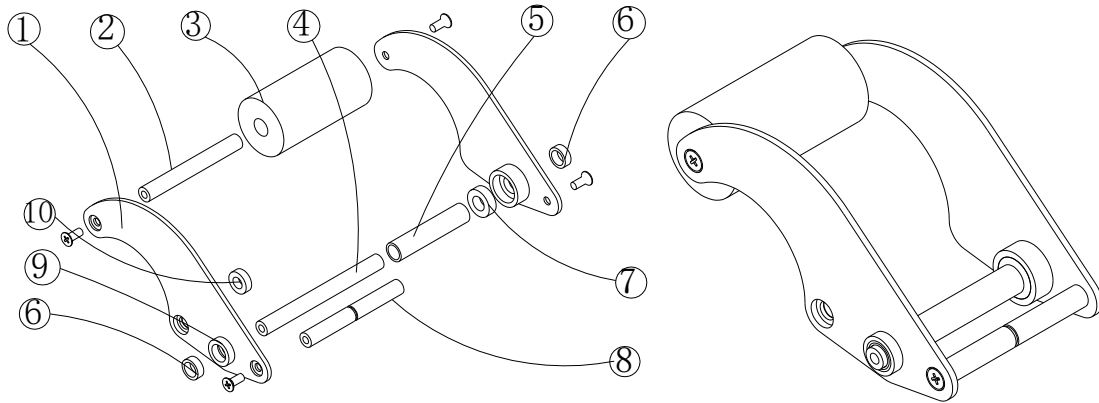

	Description	Part Number	Qty
1	Rear Connecting Plate	FJ-01-13	1
2	Front & Back Roller Shaft	FJ-00-10	1
3	Back Rubber Roller Wheel	FJ-40-03	1
4	Main Shaft	FJ-00-06	1
5	Main Shaft Sleeve	FJ-02-05	1
6	Back Locating Ring	FJ-02-06	2
7	Bearing	6800Z (26800)	2
8	Tension Spring Shaft	FJ-00-05	1
9	Washer	FJ-02-00	1
10	Bearing	688Z (208088)	1

6. Machine Parts & Illustrations

6.14 Carton Sealer - Roller Assembly

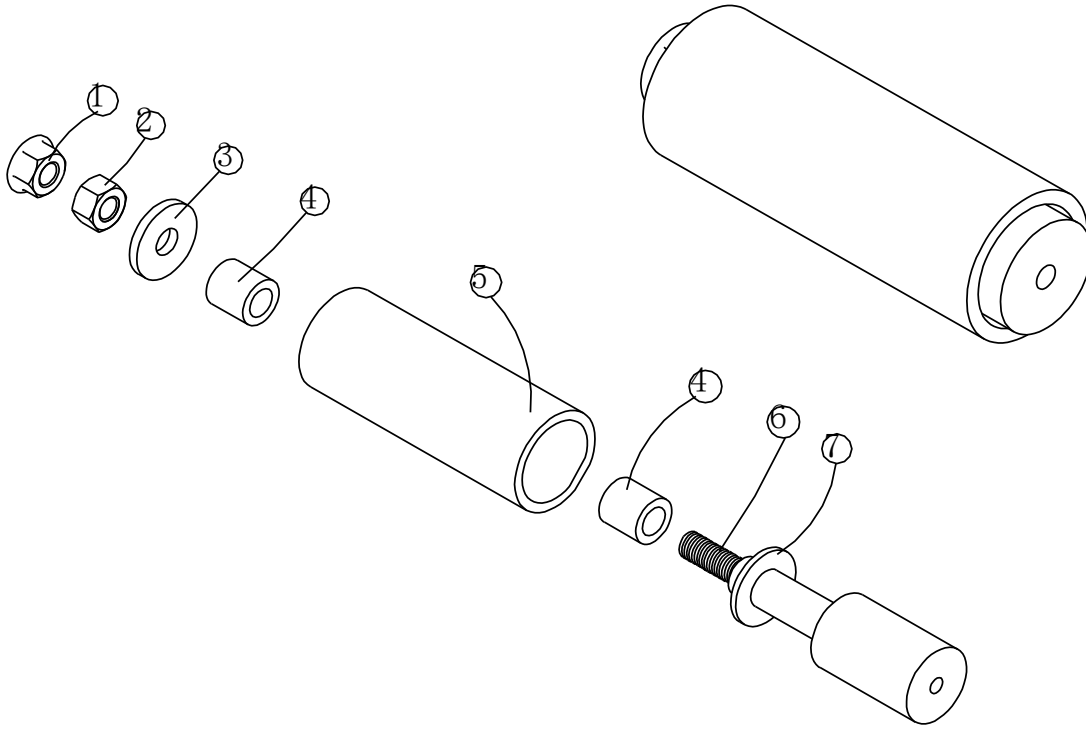

	Description	Part Number	Qty
1	Lock Nut	M8	1
2	Nut	M8	1
3	Washer	FJ-02-03	1
4	Bearing	HF1216	2
5	Roller	FJ02-00-03	1
6	Shaft	FJ-00-04	1
7	Spacer	FJ-02-01	1

6. Machine Parts & Illustrations

6.15 Guide Pulley Assembly

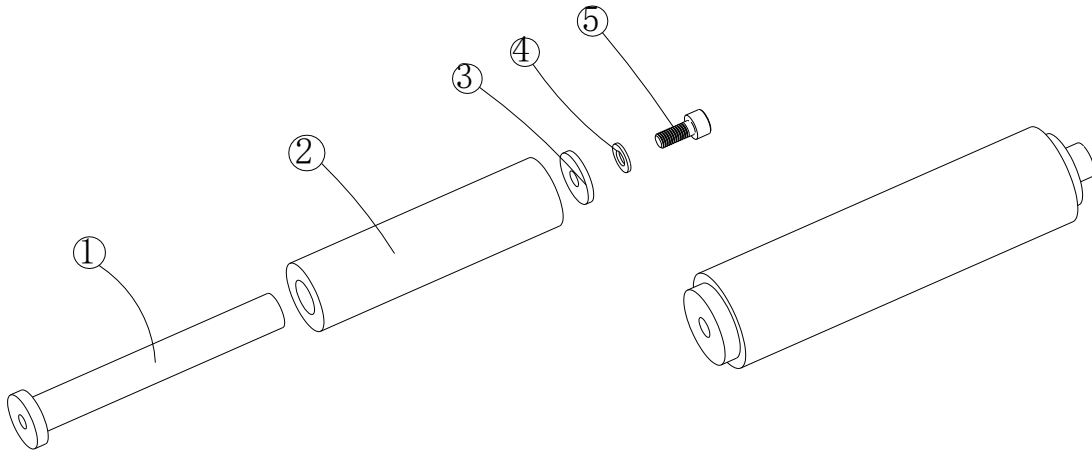

	Description	Part Number	Qty
1	Guide Pulley Shaft	M8	1
2	Axle Sleeve	M8	1
3	Washer	FJ-02-03	1
4	Flip Washer	HF1216	2
5	Hex Socket Head Screw	FJ02-00-03	1

6. Machine Parts & Illustrations

6.16 Tape Knife Assembly

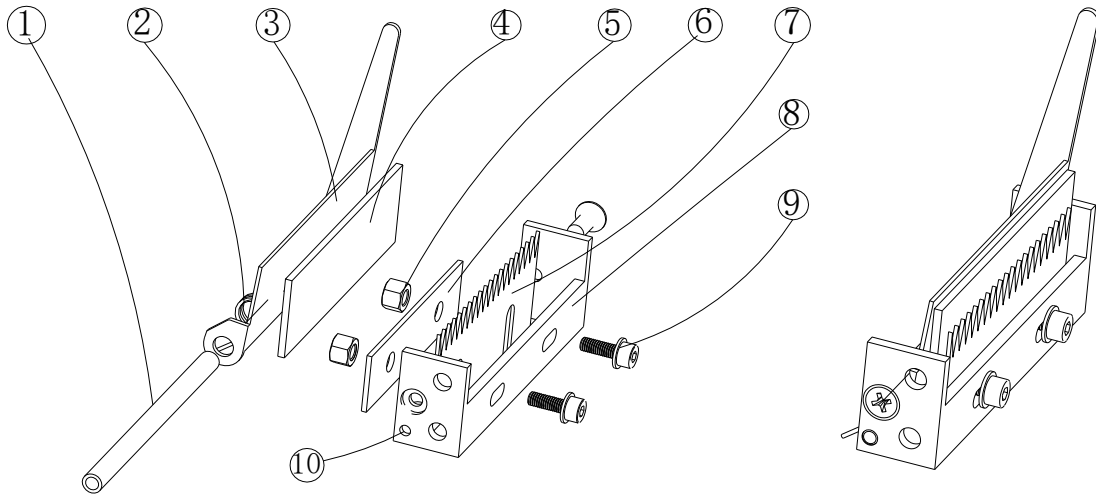

	Description	Part Number	Qty
1	Knife Back Plate Shaft	FJ-00-00	1
2	Torsion Spring	FJ-H-01	1
3	Blade Carrier Cover	FJ-01-06	1
4	Sponges		1
5	Nut	M4	1
6	Knife Board	FJ-40-04	1
7	Blade		1
8	Blade Carrier Block	FJ-01-07	1
9	Hex Socket Screw	M4x16	2
10	Cross Flat Touch Screw	M4x12	1

6. Machine Parts & Illustrations

6.17 Tape Dispenser Assembly

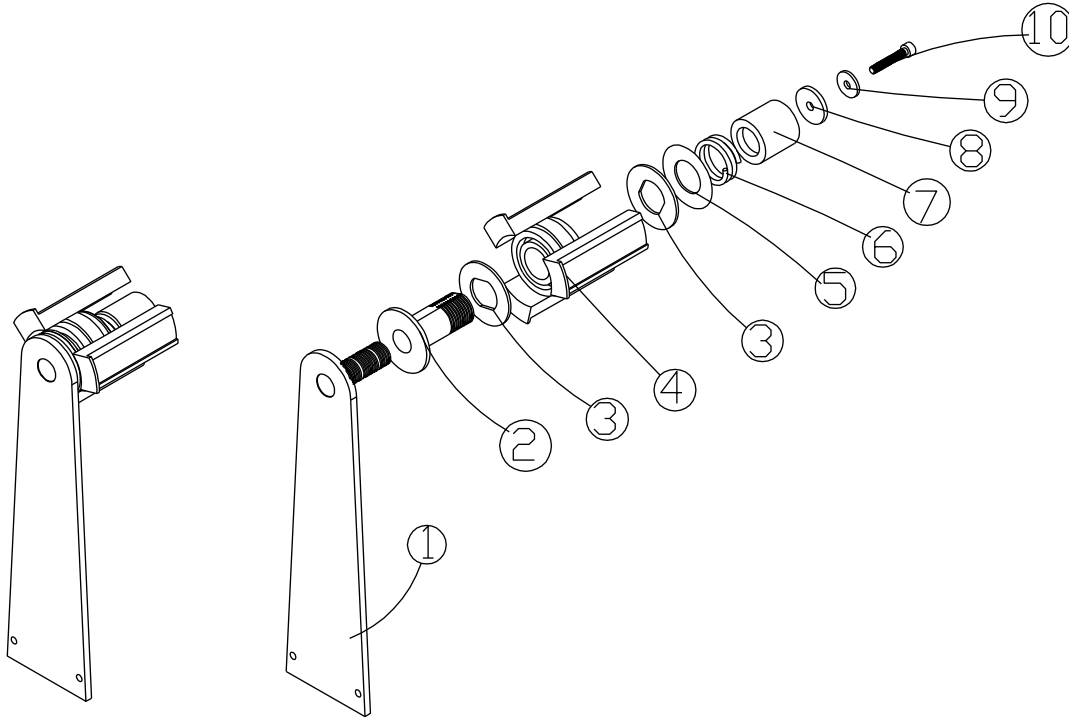

	Description	Part Number	Qty
1	Tape Head Frame	FJ-05-01	1
2	Tape Wheel Axle Sleeve	FJ-02-12	1
3	Antiskid Washer	FJ-50-01	2
4	Tape Wheel	FJ-8-40-01	1
5	Packing Washer	FJ-05-02	1
6	Pressure Spring	FJ-H-08	1
7	Hand Nut	FJ-00-14	1
8	Carrier Ring	FJ-02-08	1
9	Washer		1
10	Lock Nut	M5x40	1

6. Machine Parts & Illustrations

6.18 Tape Wheel Assembly

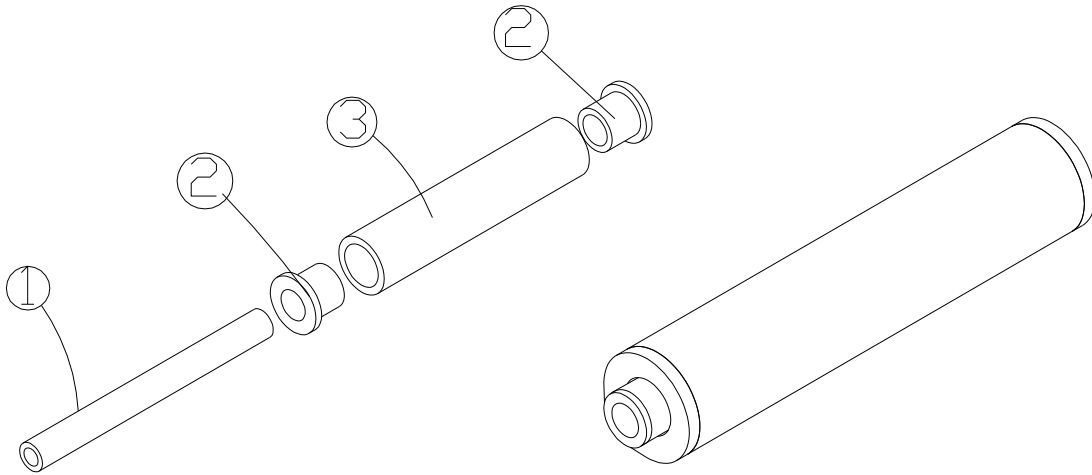

	Description	Part Number	Qty
1	Shaft	FJ-00-09	1
2	Knurled Shaft Sleeve	FJ-02-14	2
3	Tape Guide Wheel	FJ-02-13	1

6. Machine Parts & Illustrations

6.19 Tape Press Assembly

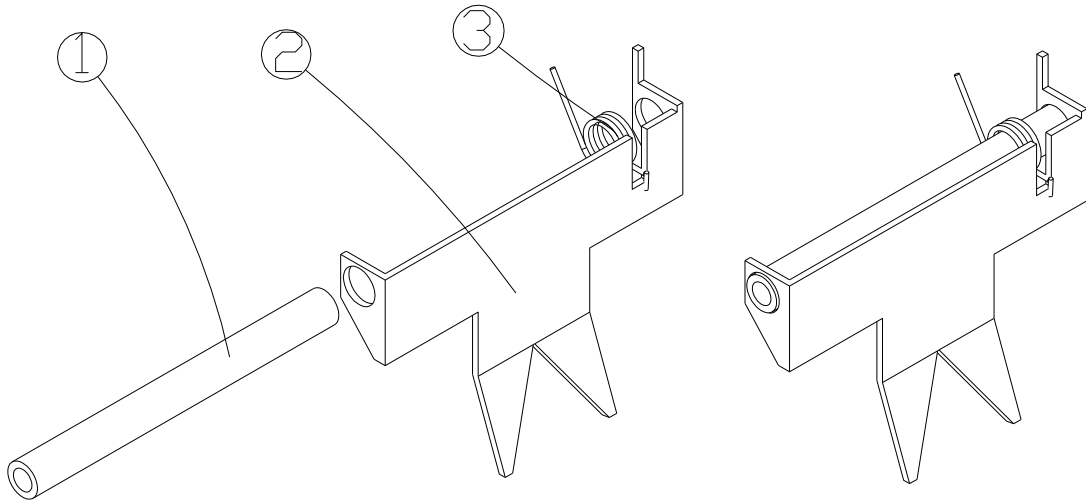

	Description	Part Number	Qty
1	Shaft	FJ-00-09	1
2	Tape Press Board	FJ-01-05	1
3	Spring	FJ-H-03	1

6. Machine Parts & Illustrations

6.20 Tape Guide Assembly

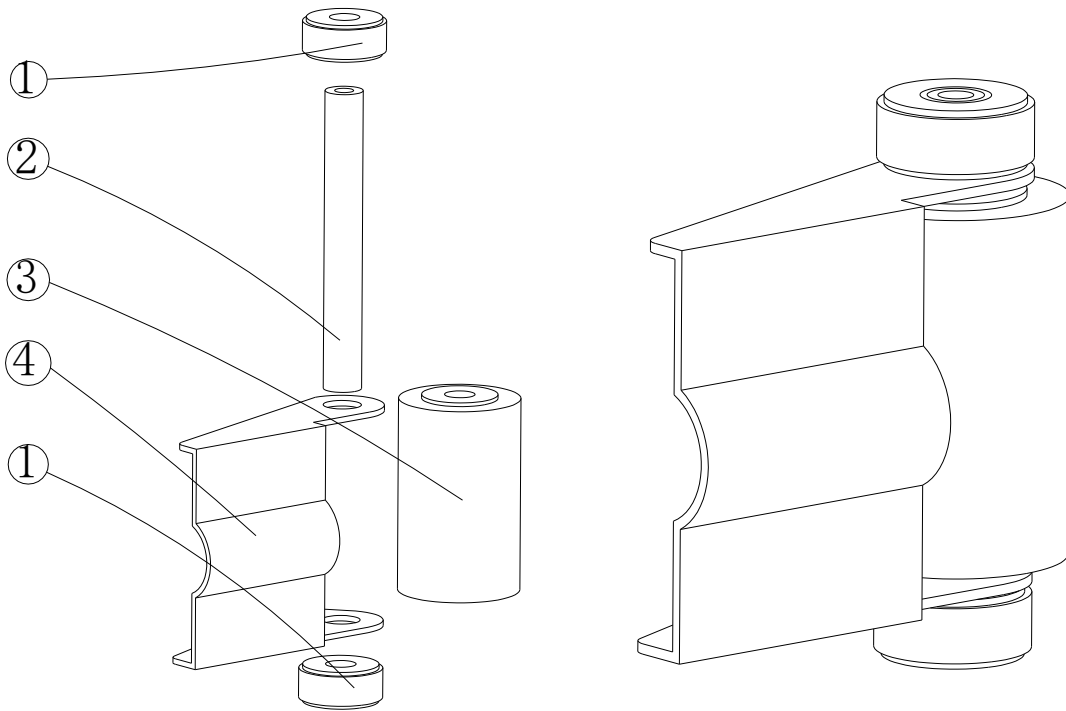

	Description	Part Number	Qty
1	Spacer	FJ-02-02	2
2	Shaft	FJ-00-10	1
3	Shaft Sleeve	FJ-02-10	1
4	Guide	FJ-01-08	1

6. Machine Parts & Illustrations

6.21 Electrical Diagrams

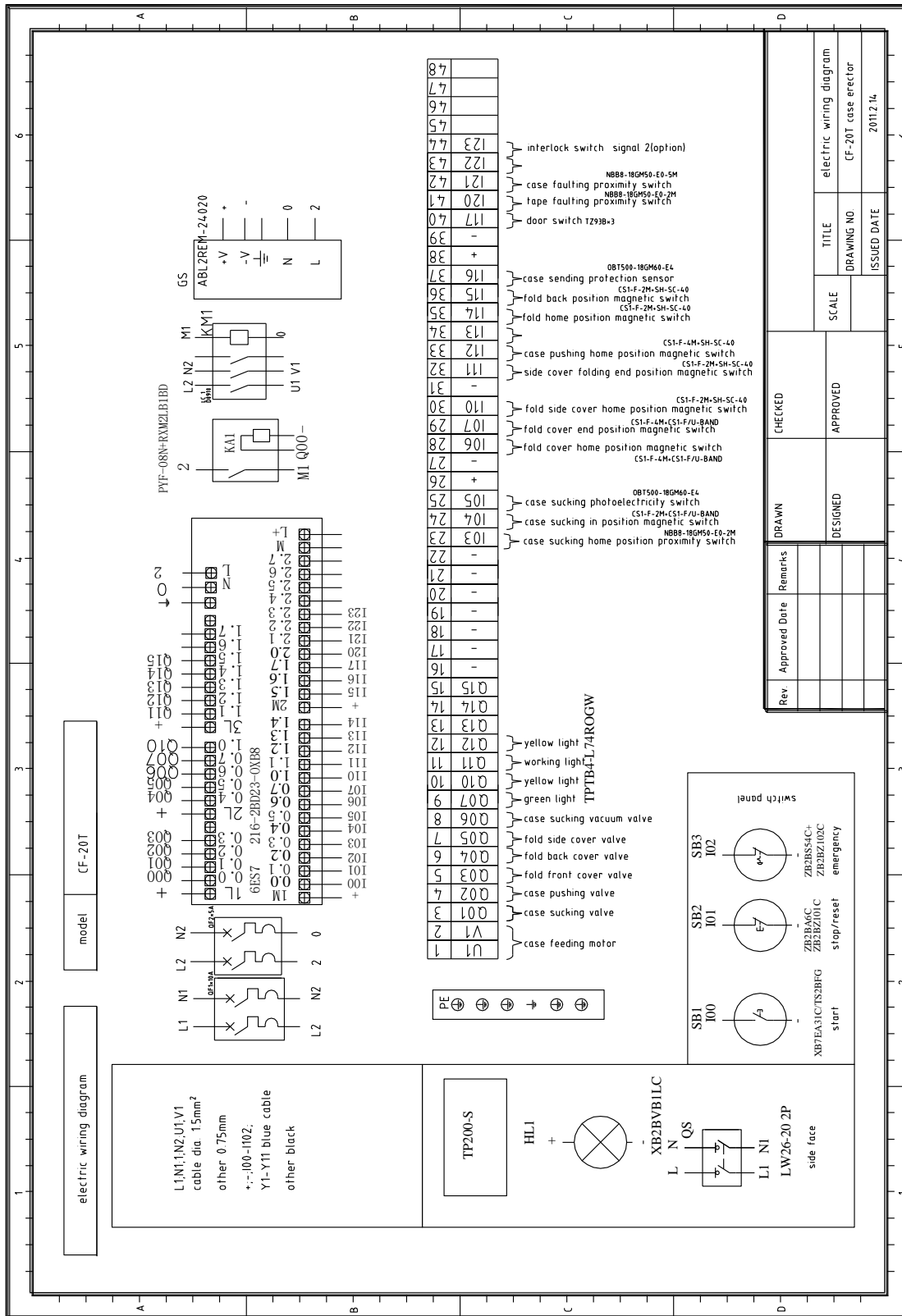

6. Machine Parts & Illustrations

6.20 Electrical Diagrams

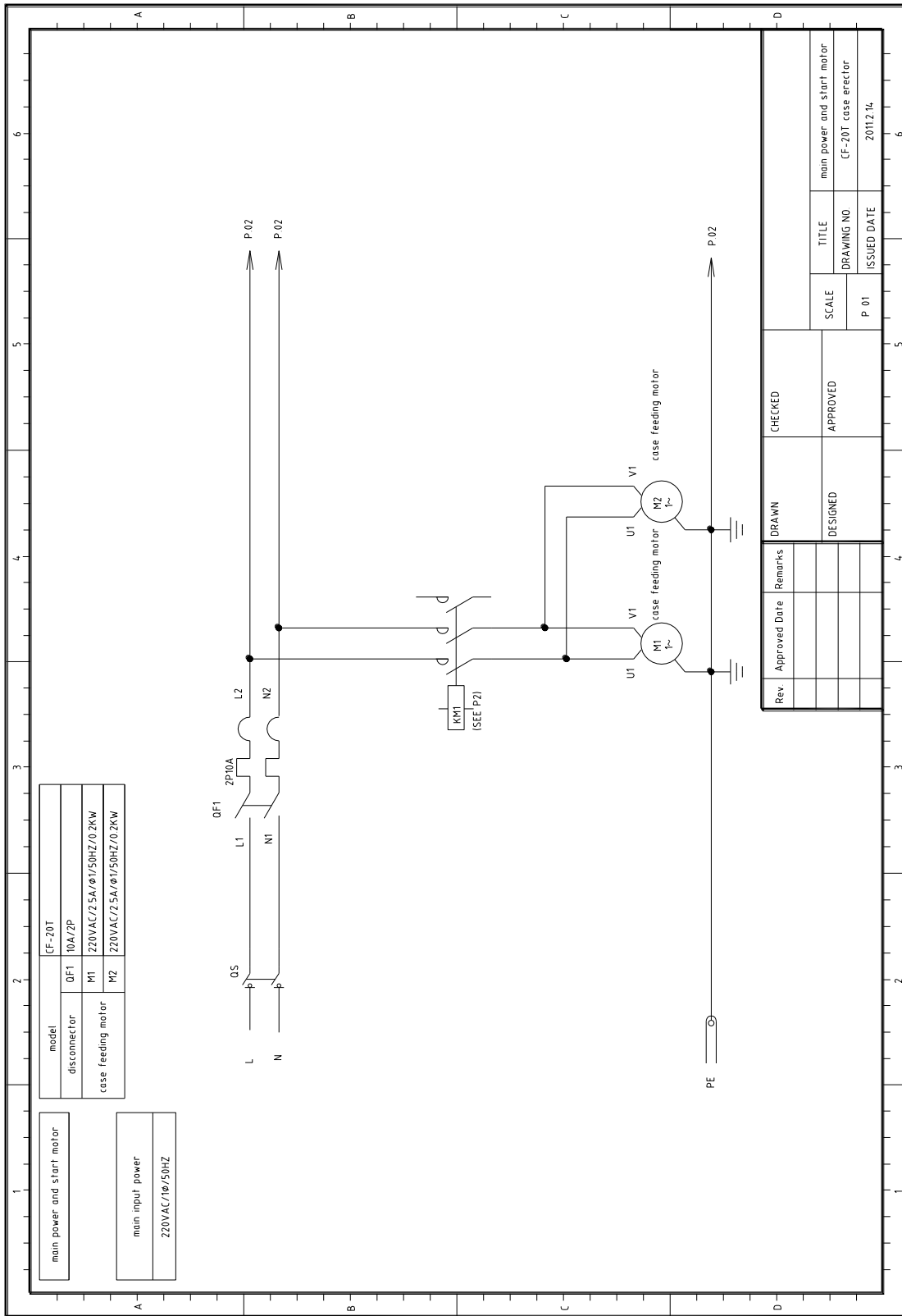

6. Machine Parts & Illustrations

6.20 Electrical Diagrams

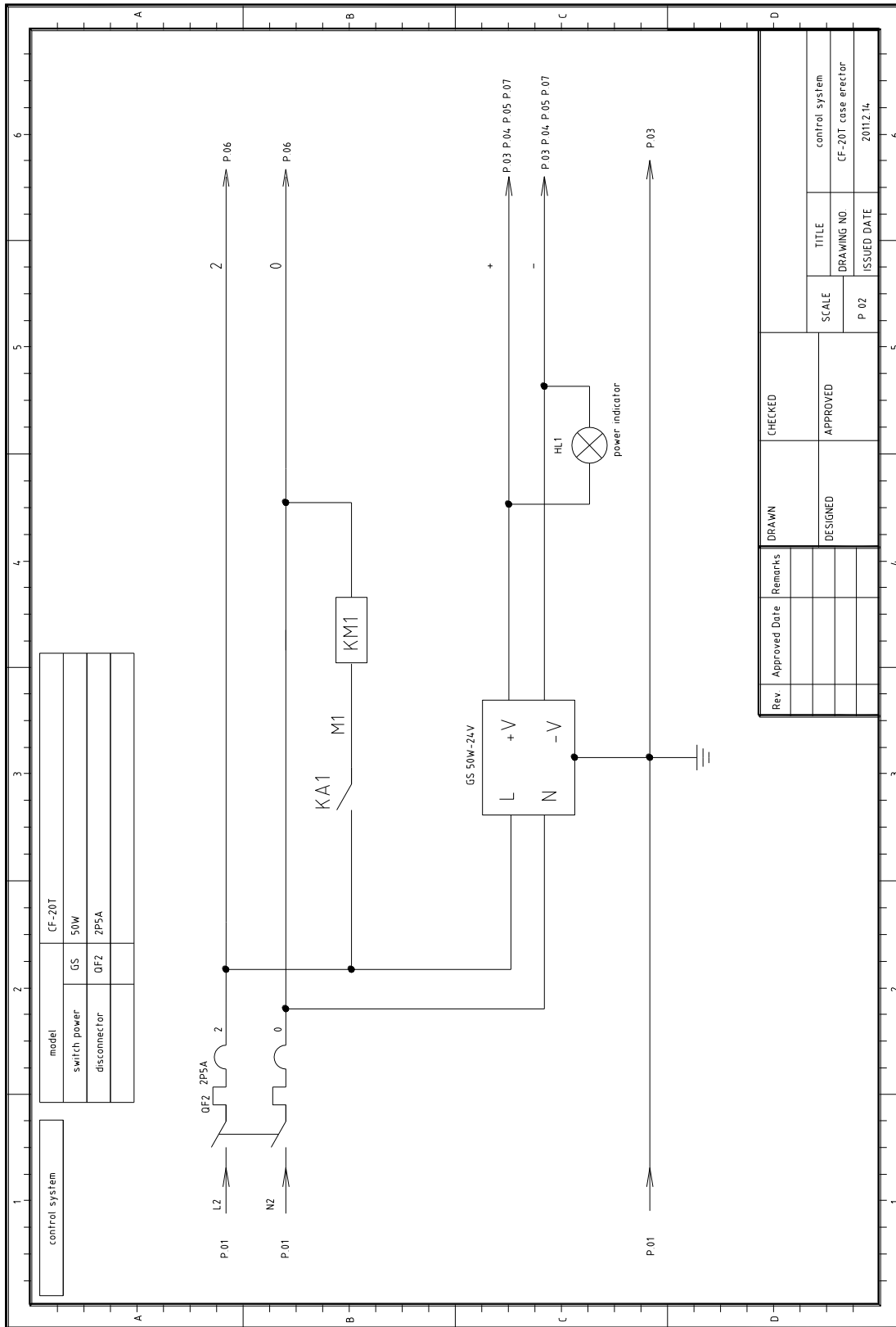

6. Machine Parts & Illustrations

6.20 Electrical Diagrams

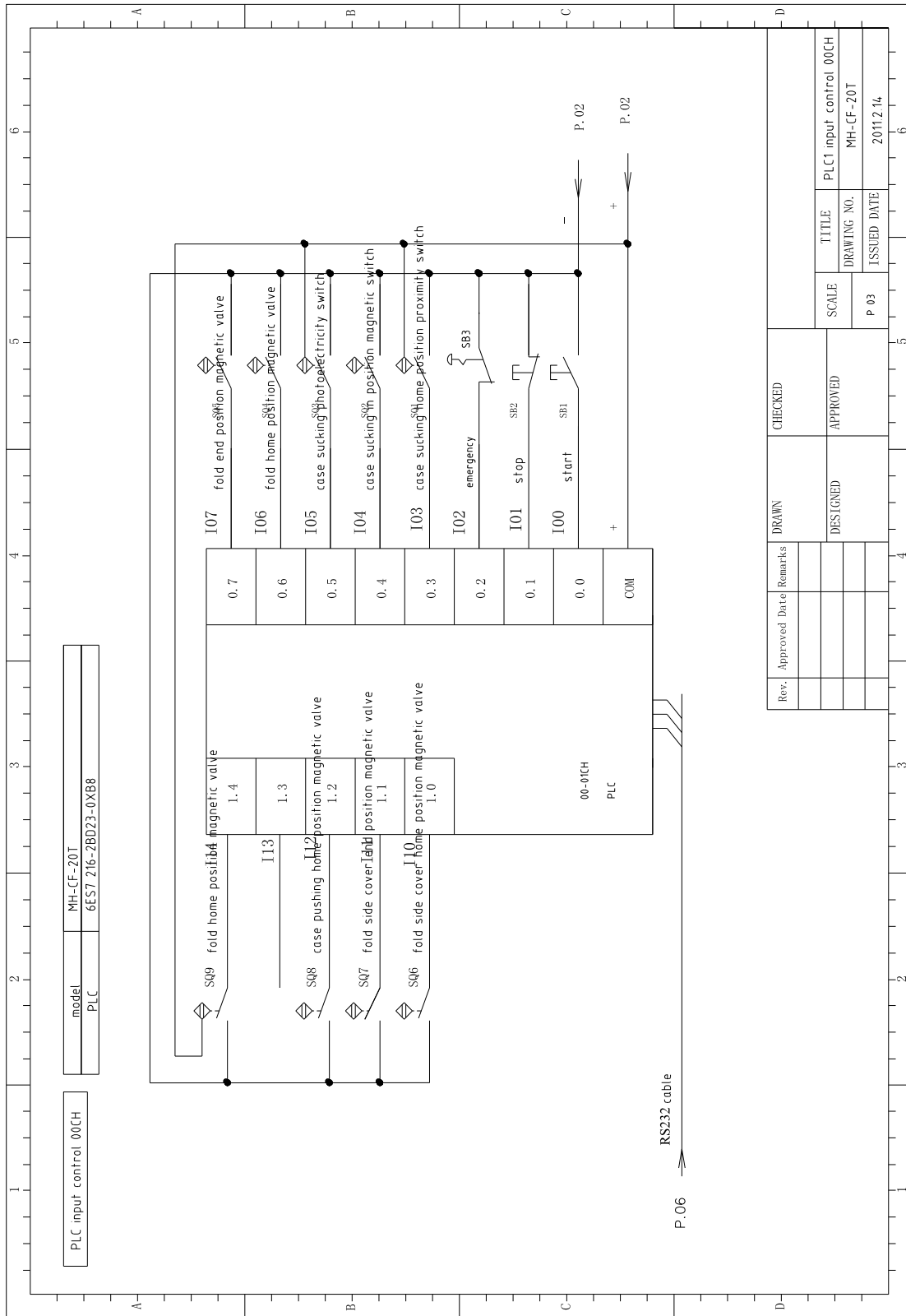

6. Machine Parts & Illustrations

6.20 Electrical Diagrams

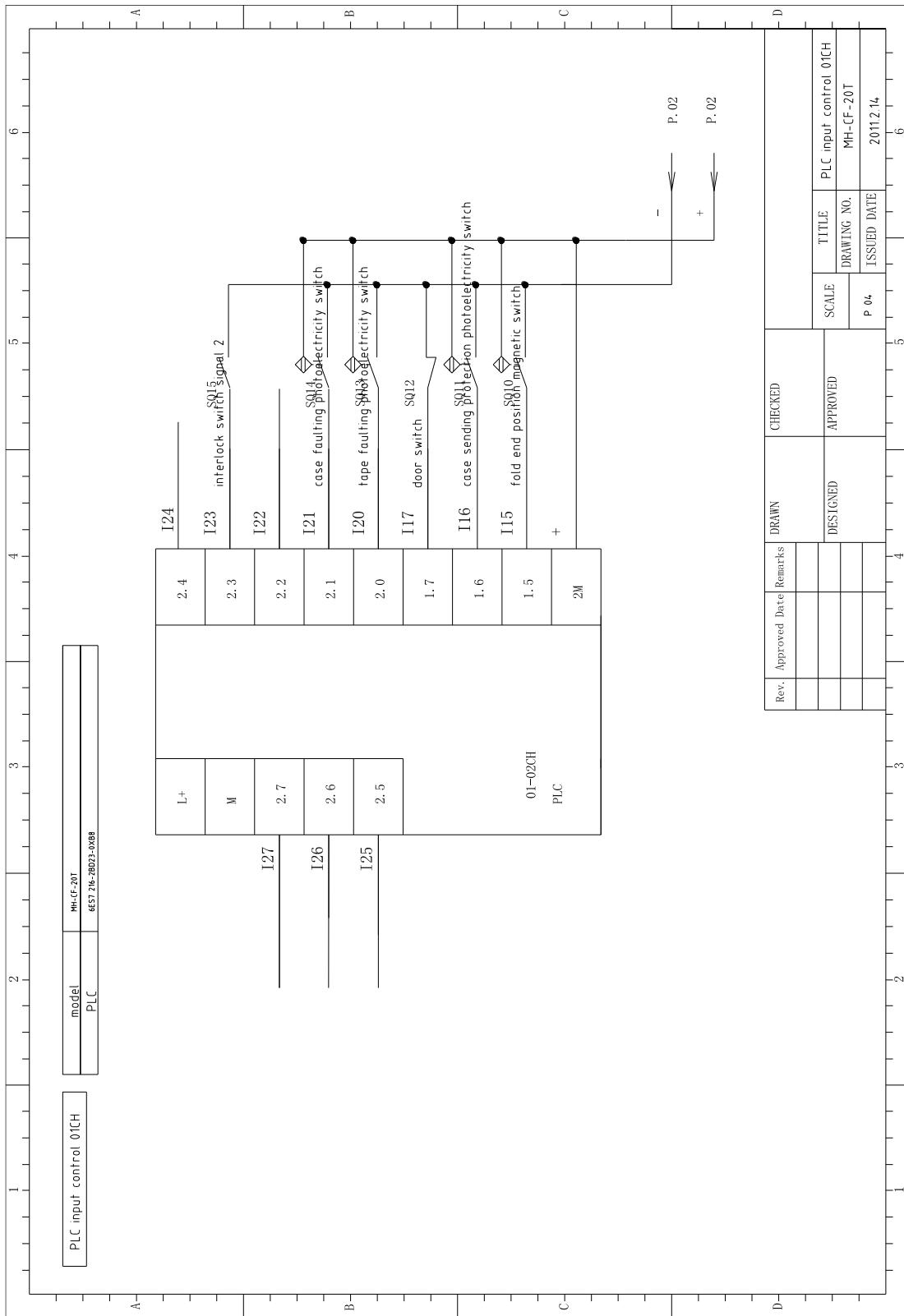

Rev.	Approved Date	Remarks	DRAWN	CHECKED	TITLE
					PLC input control 01CH
					DRAWING NO. MH-CF-20T
					ISSUED DATE 2011.2.14

SCALE
P 04

6. Machine Parts & Illustrations

6.20 Electrical Diagrams

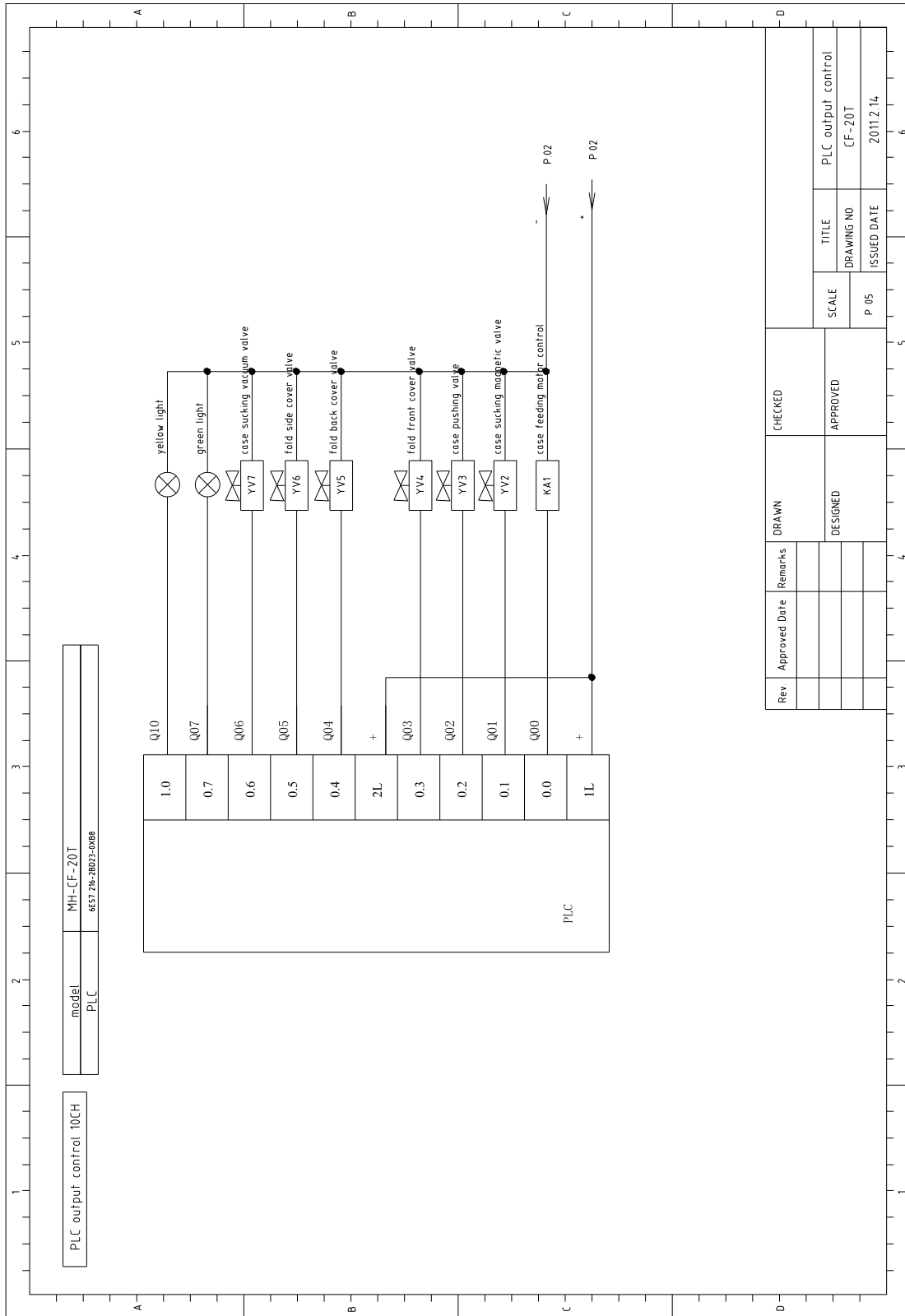

6. Machine Parts & Illustrations

6.20 Electrical Diagrams

