



OPERATING MANUAL
HDX-250 COMBINATION SHRINK SYSTEM



READ ALL INSTRUCTIONS CAREFULLY BEFORE OPERATING EQUIPMENT

TABLE OF CONTENTS



Electrical Requirements & Setup	3
Unpacking the System	
Standard Features	4
Machine Features & Specifications	
MaxAir Tunnel	
Auto-Tensioning Film Cradle	
Exact Seal System	
Package Centering System	
RS-5 Plus Digital Controller	
Balanced Magnetic Hold Down	
Seal Conveyor	
Optional Features	
Preliminary Setup & Adjustments	8
Securing the System	
Machine Controls	
Threading the Film	
Package Centering Adjustment	
RS-5 Plus Features & Controls	11
Preliminary RS-5 Controller Operation	
Changing the Controller Settings	
Controller Parameters	
Troubleshooting Guide	
Operating Procedures	14
System Operation	
Adjusting the Sealing Cycle	
Adjusting the Tunnel Temperature	
Wrapping & Shrinking a Package	
Recommended Cleaning & Maintenance.....	16
Checking the Seal Pads	
Cleaning the L Bar Sealer	
Cleaning the Shrink Tunnel	
Servicing the Heating Elements	
Troubleshooting Guide	18



INSTALLATION AND OPERATION OF THIS SYSTEM MUST BE IN COMPLIANCE WITH ALL APPLICABLE ELECTRICAL AND SAFETY STANDARDS. A QUALIFIED ELECTRICIAN MUST CHECK THE ELECTRICAL SUPPLY CIRCUIT TO INSURE CORRECT VOLTAGE AND CAPACITY. THE SYSTEM IS DESIGNED FOR INDUSTRIAL USE BY QUALIFIED PERSONNEL ONLY.

- A dedicated, single phase, 220 VAC, 23 Amp circuit is all that is required to operate the unit. The power cord for the 220 volt system is shipped without a plug on it. The electrician or service person will have to install the proper plug to match the receptacle you are using or hard wire the power cord into a wall mounted box to meet local electrical codes.

UNPACKING THE SYSTEM

- The HDX-250 system is a unitized shrink wrapping machine that combines an L Bar Sealer with a Shrink Tunnel.
- Once the system has been unpackaged, check the system for any damage or missing parts. For your convenience, a wiring diagram is packaged with your unit. Heat Seal is not responsible for damage once the equipment has left our factory. Report any damage to your distributor and the shipping company. If there are missing parts, contact your distributor immediately.

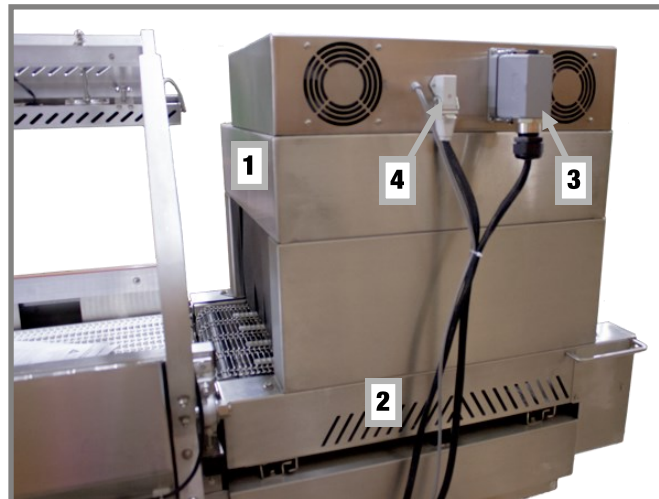

- The shrink tunnel (1) is positioned on the base unit (2) and rests on flanges of the belt.
- The tunnel chamber power has two plugs. There is a six pin plug (3) that provides power for the fan and heat element, while the four pin plug (4) provides power for the **RS-5 Plus** digital controller and tunnel RTD temperature signal.
- Extra Non-Stick tape is shipped with each L Bar Sealer. This tape prevents film build up on the sealing wire and will assist in providing better seals with most films.
- On the back of the operating console is the main system power cord. The 220 volt system is shipped without the plug. A local certified electrician or service technician will have to either install the proper plug to match the receptacle you use or hard wire the power cord into a power box to meet state and local electrical codes.

STANDARD FEATURES



MACHINE FEATURES

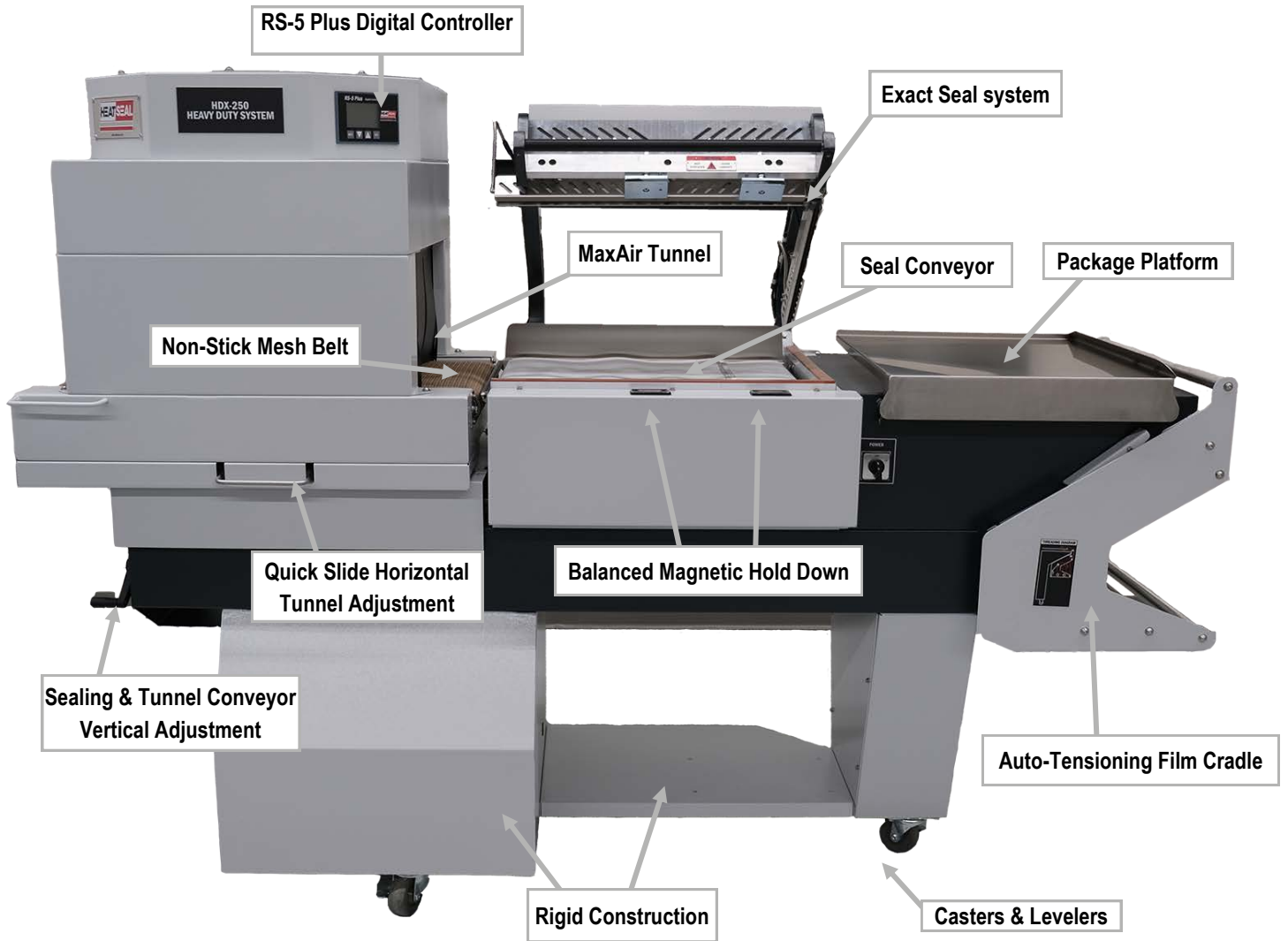

MACHINE SPECIFICATIONS

Film Capacity	22" Wide
L Bar Sealing Area	21" L, 17" W
Inside Tunnel Dimensions	21" L, 16" W, 8.5" H
Overall Dimensions	82" L, 32" W, 59" H
Working Height	38" From Floor
Power Requirement	220V, 23A, 1P
Tunnel Wattage	3,600 Watts
Tunnel Conveyor Speed	0-20 feet/minute
Weight	800 lbs.

Revised 2016

STANDARD FEATURES



MAXAIR TUNNEL

The MaxAir Tunnel (1) is designed to increase the efficiency of shrinking packages at lower temperatures. This NEW standard HDX feature with almost triple the airflow in the tunnel ensures consistent temperature throughout the tunnel to eliminate 'hot spots' and reduce recovery time. Air is wrapped evenly around the package to create an even shrink. The increased airflow makes the MaxAir Tunnel perform at its highest level without sacrificing time or energy.

AUTO TENSIONING FILM CRADLE (2)

This NEW standard HDX feature is designed to let the operator use a full roll of film down to the core, without performing any tensioning adjustments. The Auto-Tensioning Film Cradle 'senses' the size and weight of the film roll, and automatically adjusts the tension on the roll. An optional Powered Film Unwind is available for a more automated process.

EXACT SEAL SYSTEM (3)

The Exact Seal System is a NEW standard HDX feature that performs exactly as named. The frame and seal bars are connected so they will repeatedly be exactly aligned when making a seal. This feature allows for an exact and perfect seal every time.

PACKAGE CENTERING SYSTEM

The Package Centering System allows the operator to effortlessly adjust the tunnel and conveyors to produce optimal seal location on a variety of packages, and is a standard feature. The tunnel moves front to back on a Quick Slide horizontal axis and ensures that the package enters the center of the tunnel to provide a consistent and even package shrink. The Tunnel and Seal Conveyor move in tandem on a vertical axis using the adjustment handle to ensure the package seal is in an optimal location on the side of every package.

**** Before moving the Tunnel and Seal Conveyor on the Vertical Axis, the Tunnel must be moved Horizontally to the furthest position away from the operator towards the back of the machine.****

RIGID CONSTRUCTION

The base and frame of the HDX series has been engineered and manufactured to be the most durable frame yet.



STANDARD FEATURES



RS-5 PLUS DIGITAL CONTROLLER

(1)

Configuring machine controls has never been easier. The standard **RS-5 Plus** digital controller is conveniently positioned for operator ergonomics, and has a three year warranty on original machine controller. The **RS-5 Plus** is designed to be simple to use with extremely precise temperature controls. Control Panel meets the UL 508A standard.



AIR VENTING (2)

Air venting the film is required for most shrinking applications. The standard option is installed with adjustable perforating rollers to make a series of small holes continuously as the film is being drawn from the roll in the normal operation of packaging. With the heated hole punch option, the heat element located on the seal arm burns a single hole through the top layer of film.



FILM CLAMPS (3)

Film clamps ensure a good seal. The clamps are located on the front and side sealing bars, are spring loaded and set at the factory.

BALANCED MAGNETIC HOLD DOWN (4)

Magnet plates on the front of the sealing arm and magnets on the front of the sealing area are used to insure an even, consistent seal along the sealing pad. The position of the magnets have been engineered to apply the maximum seal pressure, and provide a clean seal every time.

The SEAL TIME control determines the time the magnets will hold down the arm when proper seal has been made.

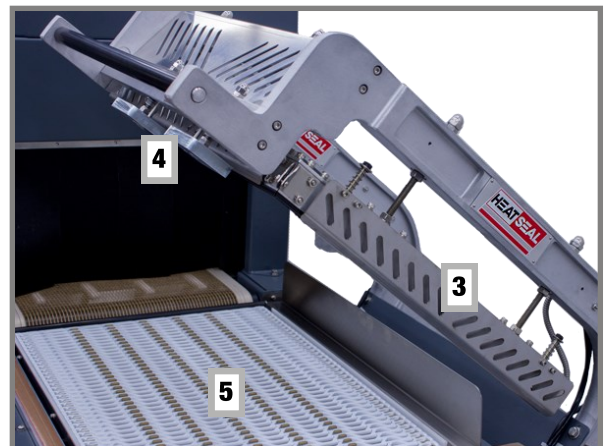

SEAL CONVEYOR (5)

This conveyor is designed to increase wrapping efficiency by automatically moving the sealed package out of the sealing area once the sealing cycle has been completed.

The SEAL CONVEYOR RUN TIME control determines how long the conveyor will run after the sealing cycle.

OPTIONAL FEATURES



STAINLESS STEEL CONSTRUCTION

The stainless steel construction option converts all hardware and painted machine parts to stainless steel. Selecting this option will not make the HDX Combo into a wash down unit. The Stainless Steel HDX Combo designed to be a wipe down machine in damp environments.

HEATED HOLE PUNCH (1)

The heated hole punch (1) is used to place one single hole in a package for air evacuation replacing the perf rollers. Typically the single hole will be covered by a label or double wrapped to provide a more complete seal in certain food applications.



E-STOP (2)

The E-Stop is an emergency stop button located on front of the shrink tunnel. Important - When plugging in the HDX for the first time press the Reset Button (3) and release the mushroom head (2) before turning the power button to the on position. Pressing this button will completely cut power to all moving components including conveyors and heaters. To return to a run state the E-Stop must be released by turning the mushroom head (2) clockwise and pressing the Reset Button (3).





IT IS NOT RECOMMENDED TO USE THE E-STOP AS THE POWER BUTTON IN NORMAL OPERATION AS IT COULD GREATLY SHORTEN THE LIFE OF THE HEATING ELEMENT IN THE TUNNEL.

POWERED FILM UNWIND (4)

The Powered Film Unwind option is used to increase speed and productivity by allowing the operator to easily insert the package into the film.

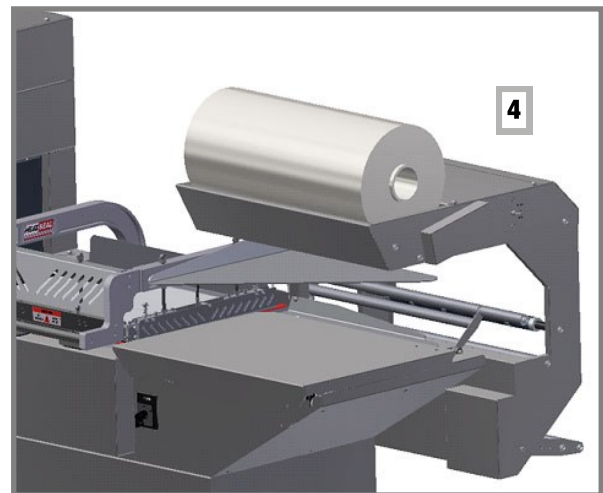

LEFT HAND REVERSE FLOW

Standard machine flow is right to left. In some situations due to production line flow or space constraints left handed operation is required. The left hand machines flows from left to right where the package to be wrapped starts on the product tray at the left, and the finished shrink wrapped package exits the shrink tunnel at the right.

SECURING THE SYSTEM

- The system is equipped with locking casters (1) for easy movement when necessary and levelers (2) to be used to level and provide stability to the system during the shrinking and sealing operation.

MANUAL RISER BAR

When needed, a riser roller can be used to add an incline/decline to the tunnel conveyor. This can be used to provide separation of the bottom of the product with the belt while traveling through the tunnel, and will improve the appearance of the bottom of the package.

- The riser roller can be raised by adjusting two screws (3) on either side of the tunnel.

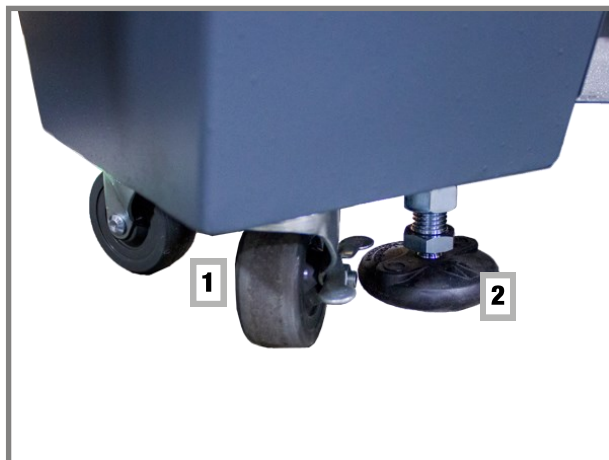

WARNING: DO NOT ADJUST THE RISER ROLLER IN A HOT TUNNEL. PERSONAL INJURY COULD RESULT. MAKE SURE THE MACHINE IS DISCONNECTED FROM THE POWER SOURCE AND THE TUNNEL IS COMPLETELY COOL TO THE TOUCH.

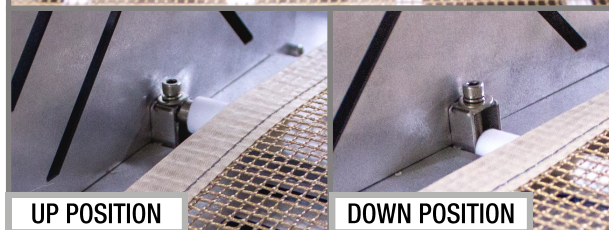
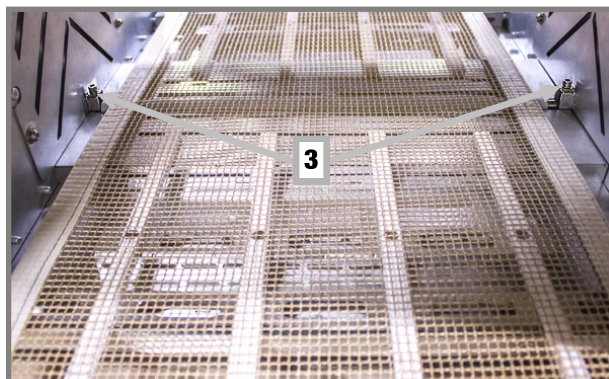

- To raise or lower the riser bar, use a 5/32 Allen Key to tighten or loosen the two riser bar screws (3). Tightening the screws will raise the riser bar, and loosening the screws will lower the riser bar.
- The riser roller should only be used for solid, single packages. Multi packs may become distorted when traveling over the roller.
- It may also be necessary to reduce the tension of the belt when raising the roller.

MACHINE CONTROLS

- This conveniently placed **RS-5 Plus** digital controller (4) is for the operation of the complete system. It controls all shrink operation functions, shrink temperature, sealing time and how frequently the conveyor moves packages out of the sealing area. It is essential that these functions be properly controlled to provide for the satisfactory performance of the system. These settings are detailed in the next few pages of this manual.



THREADING FILM

- Locate the tensioning rollers (A) inside the film cradle, attached to the side of the HDX machine. Lift the rollers up, and place the Brake Lever (B) into the notch (C) on brake panel. This will allow the tensioning rollers to remain out of the way while the film is loaded into the film cradle.
- Place roll of centerfold film on the film cradle (1) with the open side of the film (2) facing out towards the operator.
- Next, thread the film according to the threading diagram located on the operator side of the film cradle, and also shown here below (D).
- Place the package to be wrapped on the package platform (3).
- Place the top side of the open film (4) over the package to be sealed and then thread the bottom side (5) underneath the package platform to help pull film evenly from cradle.
- An HDX Film Threading instructional video is available for use on our YouTube Channel (Heat Seal LLC) using this web address: <https://youtu.be/tMywvTkA8aw>

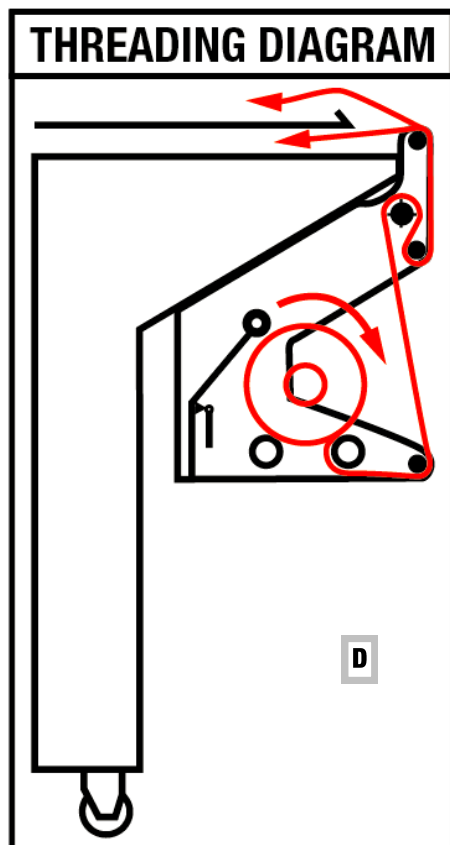

PRELIMINARY SETUP & ADJUSTMENTS



PACKAGE SIZE & FILM ADJUSTMENT

The HDX Shrink Combination Line is used to wrap a variety of different package sizes. To reduce film waste, and get the optimal package appearance and seal, follow the steps below:

- To adjust the film to different width packages, use the easily adjustable film rack slide (A) located on the operator side (front) of the shrink tunnel. Pull up on the left side of the adjustment lever (1) with your left hand, and pull out or push in the film rack (2) with your right hand. Adjust the film rack so the closed end of the film is at the back edge of the package to be sealed. Release the adjustment lever into one of the set increments (B) to lock the film rack in place.
- Using the correct width of film, this position will provide an adequate (about 2") amount of film across the front of sealing area.
- It is important that the package being sealed enters the center of the shrink tunnel. Use the horizontal quick slide adjustment to line up the package to the center of the tunnel ensuring an even shrink. Pull up on the horizontal quick slide adjustment handle (C), and slide the tunnel towards or away from the operator to line up the package to the center of the tunnel. The smaller the package, the more the tunnel will have to be slid towards the operator.
- The vertical alignment of the seal on the side of the package is achieved by using the vertical alignment handle located just below the conveyor at the exit of the shrink tunnel. This alignment will adjust the tunnel and seal conveyor (3,4) vertically in tandem to maintain level for product transfer. The vertical alignment handle (D) is rotated away from the operator to move the tunnel and seal conveyors up, and rotated towards the operator to move the conveyors down. **** Before moving the Tunnel and Seal Conveyor on the Vertical Axis, the Tunnel must be moved Horizontally to the furthest position away from the operator towards the back of the machine.****
- Make sure the middle of the package lines up with the seal pads to make sure the seal remains on the side of the sealed package.
- The above steps are a starting point and adjustments can be made to provide the appropriate amount of film around the package for shrinking and reducing the excess film.



RS-5 PLUS FEATURES & START UP



The **RS-5 Plus** is a programmable digital controller designed to control adjustable machine settings with the easy to use control pad. The digital controller is configured to control impulse or hot knife L Sealers equipped with or without a shrink tunnel.

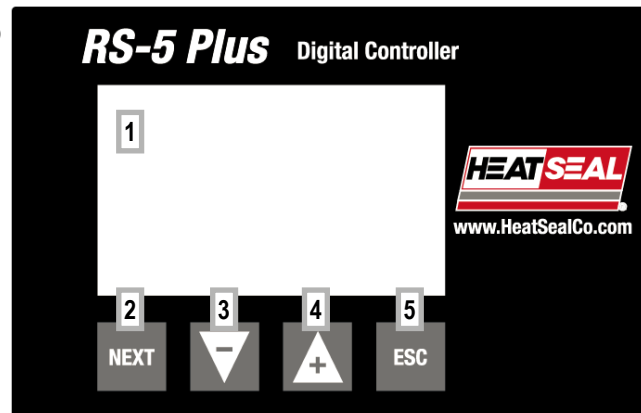

MENU SCREEN (1)

The Menu Screen displays the programmed machine settings.

NEXT (2)

The 'NEXT' button navigates through menu options.

DOWN/UP (3/4)

Both the '▼' & '▲' keys are used to make changes to individual variables within the menu options. By pressing the '▲' key, the value of the menu option will increase, and pressing the '▼' key will decrease the value.

ESC (5)

The 'ESC' key gives the operator access to the parameters. When in the 'RUN', or home menu screen, the 'ESC' key is used to access the parameters. To exit the parameter screen, the 'ESC' key is used to return back to the 'RUN' screen. After 10 seconds of inactivity the display will automatically revert to the 'RUN' or home screen.

POWERING ON AND WARM UP

If the machine is connected to service power, and the ON/OFF switch is OFF, the menu screen will read OFF.

When the ON/OFF switch is ON, the machine is beginning the warming up process. These are the screens that will show in the warm up mode:

- **For L Sealer Impulse Wire Machines**— the menu screen will change from 'OFF' to 'RUN', and is ready to begin the packaging process.
- **For L Sealer Hot Knife Machines**— the menu screen will read 'MACHINE ELEMENTS WARMING UP, PLEASE WAIT'.
- **For L Sealer Shrink Tunnel Combination Systems with Impulse Wire**— the menu screen will read 'MACHINE ELEMENTS WARMING UP, PLEASE WAIT' until the Tunnel Temp reaches the factory default or set point.
- **For L Sealer Shrink Tunnel Combination Systems with Hot Knife**— the menu screen will read 'MACHINE ELEMENTS WARMING UP, PLEASE WAIT'.

Upon reaching the temperature set points, the home screen will read 'RUN'. The operator may now begin the packaging process.



BELOW DESCRIBES MENU SETTINGS FOR COMBINATION HOT KNIFE MACHINES

SEAL TIME

'SEAL TIME' is the amount of time the magnets hold the seal bars in the sealing position. This setting ranges from 0 to 2 seconds. The factory default setting is 1 second.

TUNNEL TEMPERATURE

This menu option shows two temperature readings. The first temperature reading is the Set Point (SET), the second temperature reading is the Actual temperature (ACT) in the tunnel. The factory default setting for the Set Point is 300°F. The 'TUNNEL TEMPERATURE' has a Max setting of 350°F. Press the '▼' or '▲' keys to decrease or increase the value of the menu option.

SEAL CONVEYOR RUN TIME

The 'SEAL CONVEYOR RUN TIME' is the time the sealing conveyor runs after the seal has been made to transfer the product away from the seal area and/or into the Shrink Tunnel. The factory default setting is 2 seconds on a scale from 0 (Off) to 10 (Max) seconds. Press the '▼' or '▲' keys to decrease or increase the value of the menu option.

TUNNEL CONVEYOR SPEED

The factory default setting is set at 5 on a range from 0 (Off) to 10 (Fast). Press the '▼' or '▲' keys to decrease or increase the value of the menu option. **On retrofit kits, the Conveyor Speed is controlled by a knob on the control panel.**

SEAL CONVEYOR SPEED

The factory default setting is set at 5 on a range from 1 (Very Slow) to 10 (Fast). Press the '▼' or '▲' keys to decrease or increase the value of the menu option. **On retrofit kits, the Conveyor Speed is controlled by a knob on the control panel.**

FRONT KNIFE TEMPERATURE

This menu option shows two temperature readings for the hot knife running parallel to the seal conveyor. The first temperature reading is the Set Point (SET), the second temperature reading is the Actual temperature (ACT). The factory default setting for the Set Point is 315°F, and the Max setting is 425°F. Press the '▼' or '▲' keys to decrease or increase the value of the menu option.

SIDE KNIFE TEMPERATURE

This menu option shows two temperature readings for the hot knife crossing the path of the seal conveyor. The first temperature reading is the Set Point (SET), the second temperature reading is the Actual temperature (ACT). The factory default setting for the Set Point is 315°F., and the Max setting is 425°F. Press the '▼' or '▲' keys to decrease or increase the value of the menu option.

CYCLE COUNTER

This menu option counts the number of times the Seal Bar is pulled down to make a seal and actuates the Cycle Start Button at the back of the machine. To reset the count access the 'CYCLE COUNTER' menu screen and hold the '▲' key until the counter resets to 0. The current cycle count is visible from the Home or 'RUN' Screen.

HOT HOLE PUNCH

This menu option is only visible if the optional Heated Hole Punch is purchased with the original machine. This setting ranges from 0 (Off) to 10 (Very Hot). Press the '▼' or '▲' keys to decrease or increase the value of the menu option.

TROUBLESHOOTING GUIDE FOR HOT KNIFE MACHINES L SEALER AND COMBINATION SYSTEMS



There are four (4) alarms that can occur anytime the controller is powered. The L Sealer will not operate during any of these alarm conditions. The alarms will show orange on the screen until the solution is fixed.

1. 'FRONT KNIFE HEAT SIGNAL LOST, CHECK RTD'

- This alarm signals when the RTD for the front hot knife is disconnected or malfunctioning. The front knife is the knife closest to the operator running parallel to the face of the machine. Call a local Heat Seal distributor to properly diagnose and fix this issue.



2. 'SIDE KNIFE HEAT SIGNAL LOST, CHECK RTD'

- This alarm signals when the RTD for the side hot knife is disconnected or malfunctioning. The side knife is the knife running across the seal conveyor and parallel to the side of the machine. Call a local Heat Seal distributor to properly diagnose and fix this issue.



3. 'TUNNEL HEAT SIGNAL LOST, CHECK RTD'

- This alarm signals when the RTD for the tunnel is disconnected is malfunctioning. Call a local Heat Seal distributor to properly diagnose and fix this issue.



4. 'MACHINE ELEMENT TEMPERATURE OUT OF SPEC, PLEASE WAIT'

- This alarm will signal when either the front knife, side knife, or tunnel temperatures are out of spec. 'OUT OF SPEC' refers to the temperature being more than 10-15 ° F above or below the set point. Press 'ESC' on the RS-5 Plus digital controller to diagnose whether the front knife, side knife, or tunnel temperature is causing the alarm. Then, call a local Heat Seal distributor to properly diagnose and fix this issue.

SYSTEM OPERATION

- Due to the various types and gauges of shrink films, the sealing temperature control will require adjustment to obtain the optimum setting for the film being sealed. Always use the minimum setting that will provide a satisfactory seal to achieve maximum heat knife life and minimize replacement of the sealing pads.

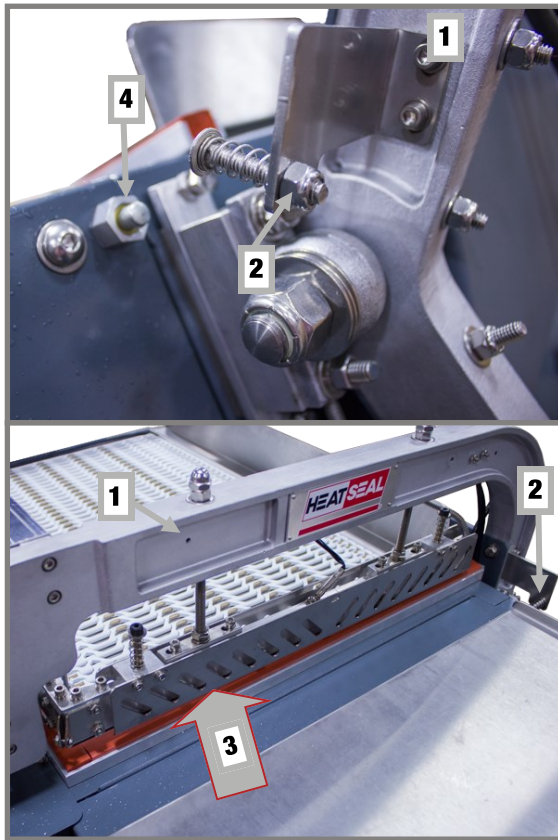

ADJUSTING THE SEALING CYCLE

Located at the back of the sealing arm (1) is an adjustment screw type actuator (2) which starts the sealing cycle as the sealing arm is brought into position. The seal cycle must start when the arm is approximately 1/8" above the seal pad (3). This is factory adjusted, however, if adjustment is required, use the following steps as a guide:

- Turn the machine off.
- Bring the arm slowly toward the seal position, the switch (4) will click when the cycle begins. If the arm is too high (over 1/8"), adjust screw away from the switch.
- If the arm reaches the seal position without actuating the sealing cycle, adjust the screw down to actuate at 1/8" above the seal pad, being careful not to extend the screw so far down as to damage the switch. Adjustments should be made no more than one turn of the screw at a time.

ADJUSTING THE TUNNEL TEMPERATURE

As with the L Bar sealer, the various types and gauges of film will require some experimenting with the temperature setting of the shrink tunnel and the conveyor speed to obtain the desired shrink. Because some time is required for the tunnel chamber to adjust to a temperature setting change, it is recommended that the conveyor speed adjustment be used to change the time exposure of the package to the available heat for shrinking. If after achieving the desired shrink of the package, the conveyor is running too slow for required production, increase the temperature setting on the tunnel. When the tunnel chamber has stabilized, increase the conveyor speed. It is recommended for the most economical operation, that the tunnel temperature be maintained at the lowest setting compatible with the shrink film and the rate of production.

WRAPPING THE PACKAGE

After threading the film from the film cradle and rack and over and under the package tray (1), seal the open end of the film with the L sealer (2) by placing open end on the seal conveyor and sealing open end, readying it to seal package.

SEALING THE PACKAGE

Place the package to be wrapped (3) on the tray inserting it between the centerfold film. Holding the product firmly with the right hand (4) and the corner of the film with the left (5), move onto conveyor.

Place package in the lower right corner near where the arms meet (6), allowing for sufficient film margin (about 2" each side) for an adequate shrink.

The arm is lowered to the sealing position which activates the sealing cycle. Magnets (7) will hold the arm in place during the cycle and release at the end of dwell cycle. The open sides of the film are sealed and is ready for the next package.

SHRINKING THE PACKAGE

The sealed package in loose film is moved out of the seal area by the seal conveyor (8) onto the tunnel conveyor belt (9). The package is conveyed through the tunnel chamber and recirculating, heated air shrinks the film creating a clear, tight package (10).

Once the first package has been wrapped, sealed and shrunk, check the package for any imperfections such as dog ears, broken seals, angel hairs and the like. These and other problems can be corrected by following the troubleshooting instructions at the end of this manual.

These procedures will help to achieve a clean and attractive seal and keep production at a maximum standard.

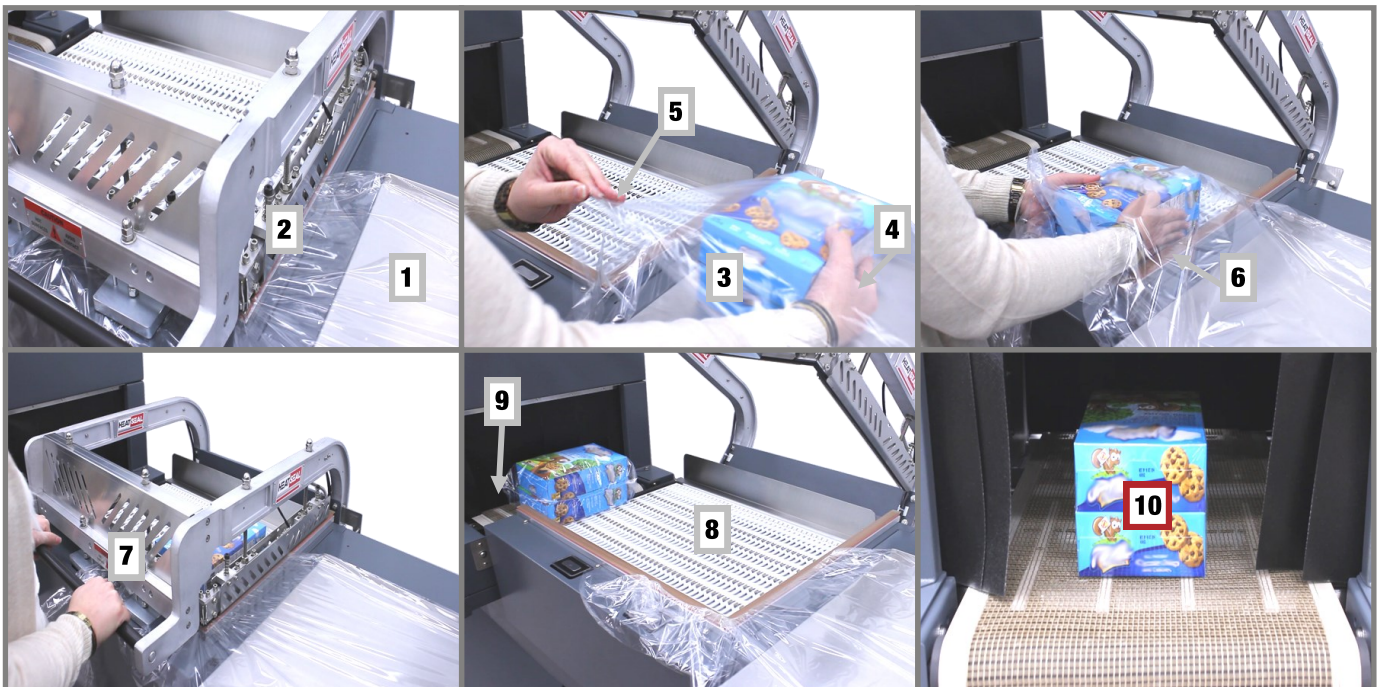



RECOMMENDED CLEANING

L BAR SEALER

HOT KNIFE	Clean with soft dry cloth only. Any abrasives will permanently damage the hot knife.
SEALING WIRES	Clean daily. Use a soft, brass wire brush. Only use a wire brush on Impulse Wire Machines.
SEALING PADS	Clean daily. Wipe clean with a cloth. Use a light duty cleaner if film buildup occurs. Replace the Teflon tape as needed.
PRODUCT TRAY	Wipe down daily.
SEAL CONVEYOR	Clean periodically. Remove to clean underneath.

SHRINK TUNNEL

CONVEYOR	Clean periodically.
EXTERIOR	Wipe down periodically.

CHECKING THE SEAL PADS

- The L Sealer seal pad will show wear from constant use and will need replaced when problems occur or it no longer provides a constant seal for your packages. See your Heat Seal Price List for replacement part information.

SERVICING THE HEATING ELEMENTS FOR HOT KNIFE SYSTEMS



MAKE SURE ALL POWER HAS BEEN SHUT OFF AND DISCONNECTED AND ELEMENTS HAVE COOLED BEFORE SERVICING THE ELEMENTS TO PREVENT PERSONAL INJURY TO THE SERVICE TECHNICIAN AND DAMAGE TO EQUIPMENT. ONLY QUALIFIED SERVICE TECHS SHOULD PERFORM THIS SERVICING.

1. When replacing an old heater rod with a new heater rod assembly, the seal bars/film clamp assembly (A) must be removed from the seal arm (B).
2. Remove the flat head screws for the wire fasteners (C).
3. Remove the four 9/16 acorn nuts (D) and 1/2 nuts from the top of the seal arm assembly (B).
4. Unplug the heater element cord (E) for the heater rod being replaced.
5. Slide the seal bars/film clamp assembly (A) out of the seal arm (B).
6. To remove the element (F) from the seal bar, loosen the set screw (G) and slide out the element.
7. Reassemble in reverse order above.
8. Restart machine and check seal head alignment.

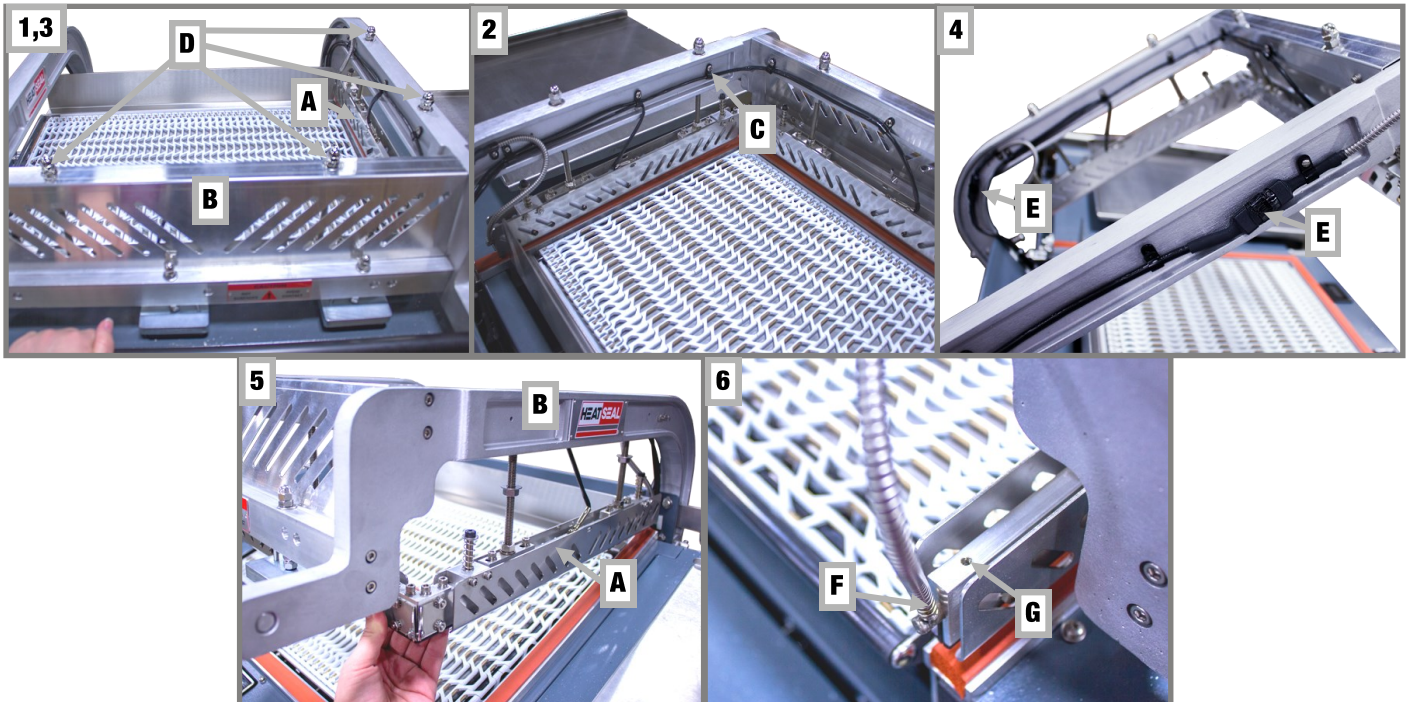

TROUBLESHOOTING GUIDE



PROBLEM: **FILM SPLITS ALONG CENTER FOLD**
SOLUTION: CHECK FOR DAMAGE TO FILM ROLL.
MAKE SURE PRODUCT TRAY IS POSITIONED CORRECTLY.

PROBLEM: **FILM SPLITS AT HOLE PUNCH**
SOLUTION: CHECK HOLE PUNCH FOR PROPER ALIGNMENT.
CHECK THE CONDITION OF THE PUNCHED HOLES.

PROBLEM: **FILM SPLITS AT TOP OF PACKAGE**
SOLUTION: CHECK HOLE PUNCH FOR PROPER ALIGNMENT.
CHECK THE CONDITION OF THE PUNCHED HOLES.
MAKE SURE THE TUNNEL IS FUNCTIONING PROPERLY.
SPEED UP THE TUNNEL CONVEYOR.
DECREASE THE TUNNEL TEMPERATURE.
ADJUST THE AIR FLOW.

PROBLEM: **FILM SMOKES EXCESSIVELY**
SOLUTION: CHECK AND CLEAN WIRE AND WIRE INSULATION.
CHECK AND CLEAN KNIFE BLADE.
CHECK CONDITION OF SEALING PADS.
CHECK CONDITION OF NON-STICK TAPE.
CHECK FOR EVEN ARM AND MAGNET PRESSURE.
CHECK THE MINIMUM SEALING TEMPERATURES.
INCREASE THE SEALING TEMPERATURES.
DECREASE THE DWELL TIME.

PROBLEM: **FILM BUILDUP ON SEALING WIRE**
SOLUTION: CHECK AND CLEAN WIRE, WIRE INSULATION OR KNIFE BLADES.
CHECK THE CONDITION OF THE SEALING PADS.
CHECK THE NON-STICK TAPE.
CHECK FOR EVEN ARM AND MAGNET PRESSURE.
CHECK THE MINIMUM SEALING TEMPERATURES.
INCREASE THE SEALING TEMPERATURES.
CHANGE THE NON-STICK TAPE.

PROBLEM: **CROWS FEET**
SOLUTION: SLOW DOWN TUNNEL CONVEYOR.
INCREASE THE TUNNEL CHAMBER TEMPERATURE.
REDUCE AMOUNT OF FILM AROUND PACKAGE.

PROBLEM: **FISH EYES**
SOLUTION: MAKE SURE TUNNEL IS FUNCTIONING PROPERLY.
SLOW DOWN TUNNEL CONVEYOR.
USE LESS FILM AROUND THE PACKAGE.
INCREASE THE TUNNEL TEMPERATURE.

TROUBLESHOOTING GUIDE



PROBLEM: ANGEL HAIR

SOLUTION: CHECK AND CLEAN WIRE, WIRE INSULATION OR KNIFE BLADES.
CHECK CONDITION OF SEALING PADS AND NON-STICK TAPE.
CHECK FOR EVEN ARM AND MAGNET PRESSURE.
CHECK THE MINIMUM SEALING TEMPERATURES.
CHECK THE SEAL CYCLE IS COMPLETE.
MAKE SURE THE MAGNETS RELEASE AT THE SAME TIME.
CHECK THE CONDITION OF THE AIR RELEASE HOLES.
INCREASE THE SEALING TEMPERATURES.
CHANGE THE NON-STICK TAPE.

PROBLEM: DOG EARS

SOLUTION: USE LESS FILM AROUND THE PACKAGE.
SLOW DOWN THE TUNNEL CONVEYOR.
CHECK THE CONDITION OF THE AIR RELEASE HOLES.
INCREASE THE TUNNEL TEMPERATURE.

PROBLEM: BURN HOLES (HOT SPOTS)

SOLUTION: CHECK THE CONDITION OF THE AIR RELEASE HOLES.
SPEED UP THE TUNNEL CONVEYOR.
DECREASE THE TUNNEL CHAMBER TEMPERATURE.

PROBLEM: ERRATIC SHRINK

SOLUTION: MAKE SURE THE TUNNEL IS FUNCTIONING PROPERLY.
SLOW DOWN TUNNEL CONVEYOR.
ADJUST THE TUNNEL AIR FLOW.
INCREASE TUNNEL CHAMBER TEMPERATURE.

PROBLEM: SEVERE BALLOONING

SOLUTION: INCREASE THE TUNNEL TEMPERATURE
CHECK CONDITION OF AIR HOLES.

PROBLEM: OFF-CENTERED SEAL

SOLUTION: ADJUST THE PACKAGE PLATFORM.
LOOSEN THE KNOBS ON THE IMPULSE WIRE TENSION BLOCKS.

PROBLEM: FILM CAN'T SEPARATE, STATIC OR FILM COLLAPSES PACKAGE

SOLUTION: CALL YOUR FILM SUPPLIER.

- ANY OF THE PRECEDING TROUBLESHOOTING PROCEDURES DO NOT WORK, PLEASE CALL YOUR LOCAL HEAT SEAL DISTRIBUTOR SERVICE FOR FURTHER ASSISTANCE.

