



Low-Profile Semi-Automatic Stretch Wrap Machine

HANDLE-IT® SA Series

Model 800

Full Set of Functions and Options

Electronic Film Tension

100 Max Average Pallets Per Day!

3 YEAR WARRANTY



Part Number
SWM-SA-0800

Handle-It® Model 800

The Handle-It® Model 800 offers top-of-the-line functions and features at a great price. It is ideal for those who are looking for an efficient machine capable of handling moderate to high volumes of pallets per day.

Technical Specifications

Wrap Height	86"
Turntable Diameter	59"
Max Pallet Size	48" x 80" (93" Diagonal)
Turntable Height	3"
Weight Capacity	4,400 lbs
Electronic Film Tension	Variable
Power Supply	110V, 10 Amp
Total Machine Footprint	93" long x 60" wide
Machine Weight	600 lbs
Turntable Speed	13 RPM

Handle-It® Semi-Automatic Stretch Wrapper

Product Specifications

- Frequency controller for turntable speed adjustment (from 3 to 13 RPM)
- Frequency controller for carriage speed adjustment (speed going up and speed going down can be set differently)
- Electromagnetic brake for film stretching
- Photocell for pallet height detection with photo eye delay
- Safety stop at the base of the carriage
- Stop at 0 position
- 2 access keys (including lock mode)
- Many parameters available at upper password level
- Reinforcing operation
- 3 working cycles: ascent/descent; topsheet; only ascent
- 9 wrap programs can be saved by the customer
- 9 additional recordable playback cycles can be saved
- 3 year warranty



Adjustable parameters by the control panel:

cycle selection, bottom turns, top turns, rotation speed, carriage speed going up, carriage speed going down, film tension.



Electromagnetic film tension with easy film threading

Available Options

- Integrated Scale
- Loading Ramp
- Photocell for Dark Loads
- Upgrade to the SWM-SA-850PS for 250% power film pre-stretch
- Extended height: 98"
- Forklift wheel stop
- Guarding



Integrated Scale



Forklift Wheel Stop



Ramp

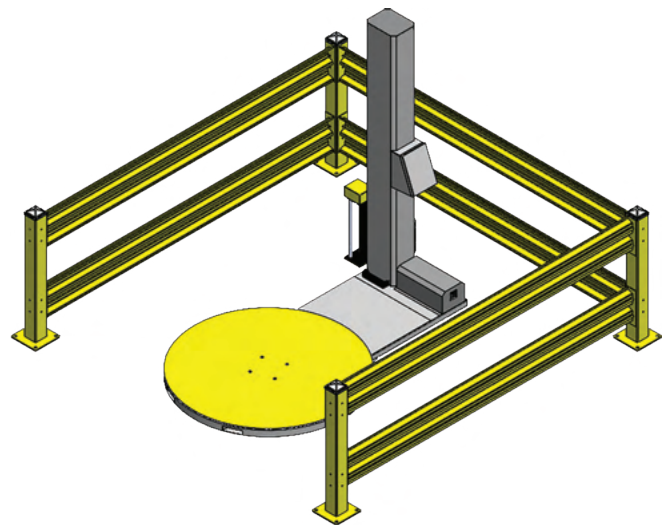

3-Sided Guard Rail Package