

THE RELIABLE SOLUTION TO GIVE YOU A BOOST

IN EFFICIENCY
CARTON ERECTING SOLUTION

HIGH-TECH MARVEL

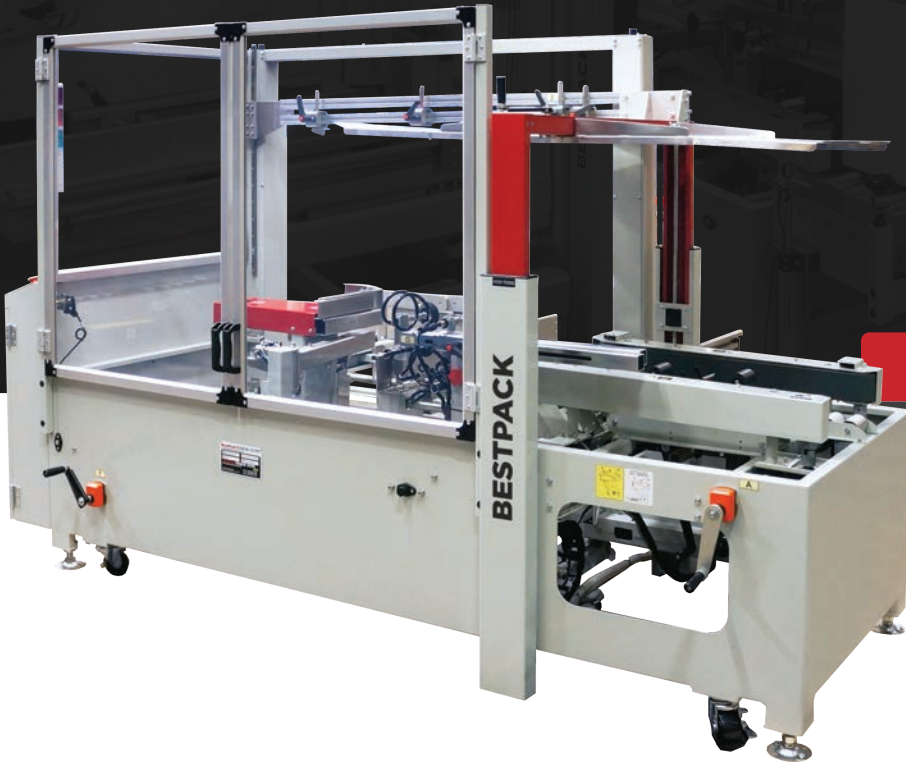

QUICK HIGHLIGHTS

SEALS UP TO 15 CARTONS PER/MIN.*

*SPEED DEPENDENT ON CARTON SIZE AND MACHINE OPTIONS

- Quick Carton Changeover
- Dedicated Vacuum Pump Suction Cup System
- Virtual Support Materials
- Includes Carton on Demand Sensors

CARTON RANGE

Specifications based on ELVS22-2

Length (min. - max.) (8.0" - 25.0)	Width (min. - max.) (5.0" - 20.0")	Height (min. - max.) (3.0" - 21.5")
---	---	--

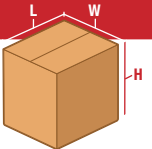

ELVS AUTOMATIC L-TYPE SUCTION CUP

The BestPack™ Model ELVS is an innovative, high-performance carton erector/sealer. This erector is built for heavy usage with quick and simple carton size changeover. There are no tools required for carton size changeover. The ELVS handles a wide range of carton sizes.

All BestPack units are available in our standard baked enamel finish and food grade 304 stainless steel for 21 CFR 110 compliance.



FREE PRODUCT SUPPORT:
TRAINING VIDEOS | ONLINE MANUALS | TECH SUPPORT

*CONTACT YOUR LOCAL BESTPACK REPRESENTATIVE FOR MORE INFORMATION

WWW.BESTPACK.COM

VERSION 5.0_1023



CNC CUT AND WELDED FRAME/LEGS
4x longer lasting than bolted frames.



VACUUM PUMP SUCTION CUP SYSTEM
Dedicated air system providing reliable erecting.

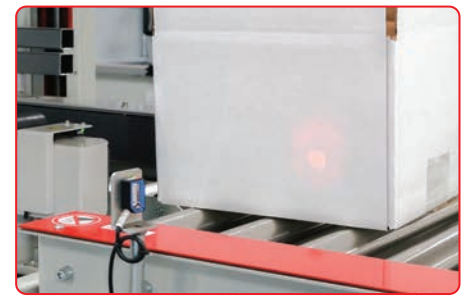

CARTON ON DEMAND SENSORS
Included with your ELVS carton erector, preventing carton jamming & down time

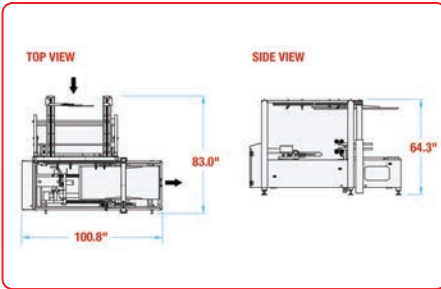

SMALL FOOTPRINT
Industry leading compact design, easily integrated into your existing packaging line.



TAPE MONITORING SYSTEM
Low tape, no tape and no cut monitoring system, notifies the user of potential downtime.



ACCESSIBLE TECHNICAL SUPPORT
Convenient technical support is readily available via a QR code on solution.

MACHINE FOOTPRINT

Specifications based on ELVS22-2

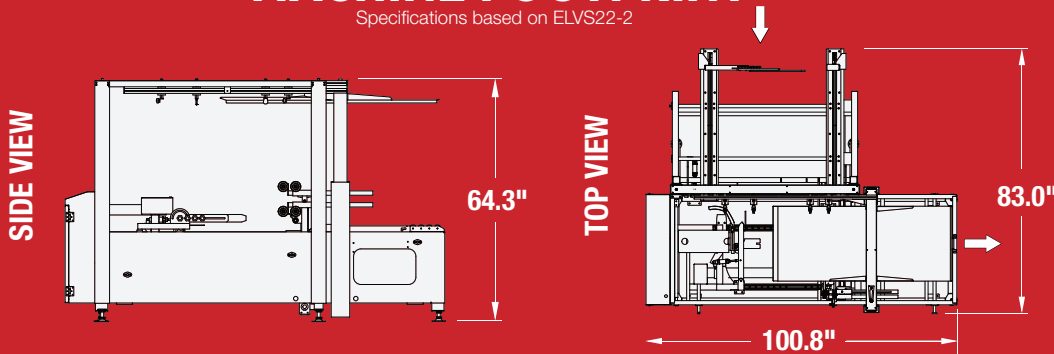

Note: Dimensions are all subject to change without prior notification.

OPTIONS

- Available in Stainless Steel
- eWon VPN Wifi Module
- Continuous-Feed Hopper
- HMI-Human Machine Interface

POPULAR ELVS MODELS

PLEASE REFER TO COMPARISON CHART FOR COMPLETE LIST OF MODELS.

MODEL	MACHINE DIMENSIONS LENGTH x WIDTH x HEIGHT	CARTON RANGE* LENGTH (min. - max.) x WIDTH (min. - max.) x HEIGHT (min. - max.)	CONVEYOR HEIGHT HEIGHT (min. - max.)	CARTONS PER MIN.	SHIPPING WEIGHT (LBS)	POWER REQUIREMENTS	AIR REQUIREMENTS
ELVSL21-2 2" Tape Head	(100.8") x (83.0") x (64.3")	(8.0" - 20.0") x (5.0" - 14.5") x (3.0" - 14.0")	(25.5" - 31.5")	Up to 10-15	1,800	110 Volts 60 Hz	80 PSI, 10 SCFM
ELVSL22-2H 2" Tape Head	(100.8") x (83.0") x (64.3")	(8.0" - 25.0") x (5.0" - 20.0") x (3.0" - 21.5")	(25.5" - 31.5")	Up to 10-15	1,800	110 Volts 60 Hz	80 PSI, 10 SCFM
ELVSR22-2H 2" Tape Head	(100.8") x (83.0") x (64.3")	(8.0" - 25.0") x (5.0" - 20.0") x (3.0" - 21.5")	(25.5" - 31.5")	Up to 10-15	1,800	110 Volts 60 Hz	80 PSI, 10 SCFM
ELVSL22-3H 3" Tape Head	(100.8") x (83.0") x (64.3")	(8.0" - 25.0") x (5.0" - 20") x (3.0" - 21.5")	(25.5" - 31.5")	Up to 10-15	1,800	110 Volts 60 Hz	80 PSI, 10 SCFM
ELVSR22-3H 3" Tape Head	(100.8") x (83.0") x (64.3")	(8.0" - 25.0") x (5.0" - 20") x (3.0" - 21.5")	(25.5" - 31.5")	Up to 10-15	1,800	110 Volts 60 Hz	80 PSI, 10 SCFM

INFORMATION SUBJECT TO CHANGE WITHOUT NOTICE.

ALL MODELS AVAILABLE IN FOOD GRADE 304 STAINLESS STEEL.



For more information please go to:
WWW.BESTPACK.COM or call us at **1.888.588.2378**