

HEAVY DUTY COMBO SHRINK SYSTEM

MODEL: HDX250



FEATURES

CONTROL PANEL

- Conveniently Positioned, **RS-5 Plus** Digital Controller with Three Year Warranty on Original Machine Controller
- Meets UL 508A Standard
- Simple Operation and Precise Temperature Controls
- Cycle Counter Comes Standard with Reset
- Single Cord 220V Single Phase Power Supply

SEALING AREA

- Hot Knife Exact Seal System with Multiple Profile Options
- Large 17" W by 21" L Seal Area
- Heavy Duty Cast Aluminum Seal Head with Stainless Film Clamps
- Balanced Magnetic Hold Down for Strong, Consistent Seals
- Seal Conveyor with Smooth Product Transfer from Seal Area to Tunnel

SHRINK TUNNEL

- Non-Stick Mesh Tunnel Belt with Adjustable Riser Bar for Improved Bottom Shrink
- Efficient MaxAir Tunnel Almost Triples the Airflow and Evenly Wraps Air Around Package
- Automatic Cool Down Extends Heating Element Life



HDX250

OTHER FEATURES

- Package Centering System for Even Shrink - Sealing and Tunnel Conveyor Move in Tandem Vertically. Also, Includes Tunnel Horizontal Quick Slide Adjustment.
- Two Year Warranty
- Four Individually Adjustable Perforating Wheels
- Auto Tensioning Film Cradle
- Heavy Duty Casters and Levelers

MODEL SPECS

FILM CAPACITY	22" Wide (56 cm)
L BAR SEALING AREA	17" W, 21" L (43 W, 53 L cm)
INSIDE TUNNEL DIMENSIONS	21" L, 16" W, 8" H (53 L, 41 W, 22 H cm)
TUNNEL CONVEYOR SPEED	0-20 Feet per Minute (0-6 meters per minute)
OVERALL DIMENSIONS	82" L, 32" W, 59" H (208 L, 82 W, 150 H cm)
WORKING HEIGHT	38" (97 cm)
POWER REQUIREMENTS	220 Volts, 23 Amp, Single Phase
TUNNEL WATTAGE	3,600
WEIGHT	800 lbs. (363 kg)

AVAILABLE OPTIONS

- Fully Stainless Steel Construction
- Added Heated Hole Punch
- Tunnel Belt Options: Stainless Steel Wire Mesh OR Live/Dead Rollers
- Left Hand Reverse Flow
- Spare Parts Kit
- Powered Film Unwind with Perforating Roller and Adjustable Inverting Head
- GTC180/16- 180 Degree Gravity Turn Around Conveyor
- GTC90/16- 90 Degree Gravity Turn Around Conveyor
- AT36- 36" Rotary Accumulator Table
- AT48- 48" Rotary Accumulator Table

Revised 2015



HEAVY DUTY COMBO SHRINK SYSTEM

MODEL: HDX250



MACHINE FOOTPRINT

LENGTH (L)	82"
WIDTH (W)	32" Tunnel Retracted 40" Tunnel Pulled Out
HEIGHT (H)	59" Tunnel Lowers 4"

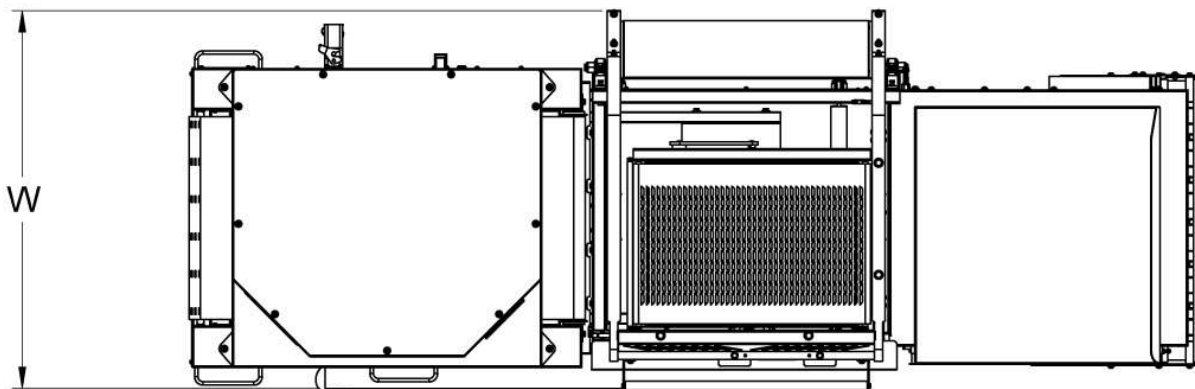
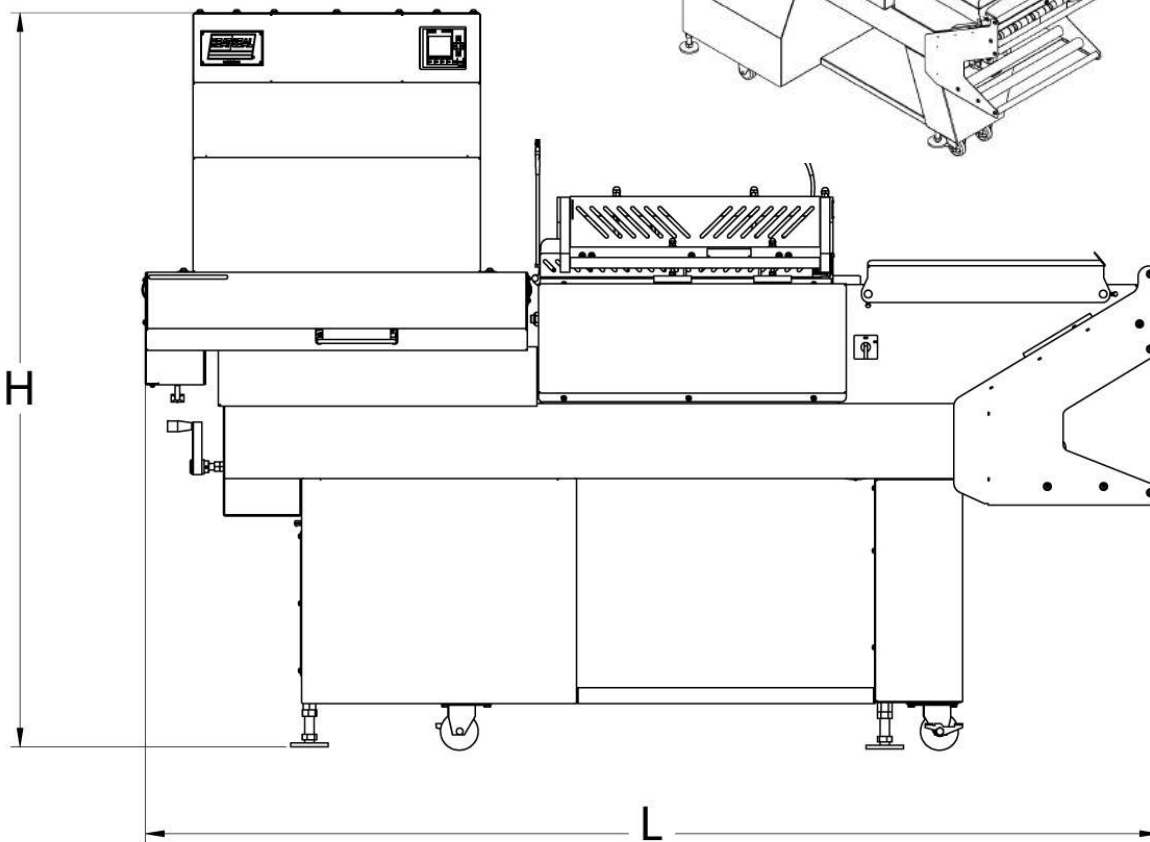
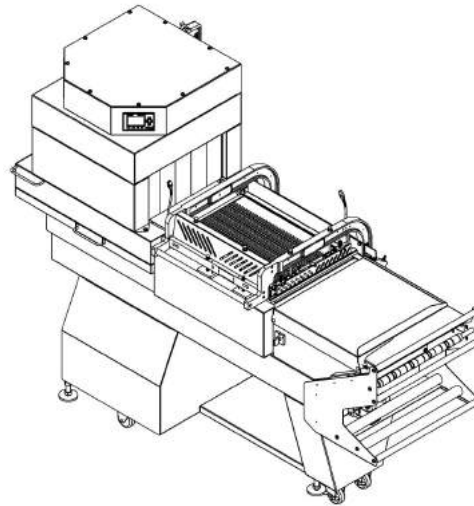

Revised 2015

